



# VSRT™

## Vertical Spiral Rib Tubeless Steam Boilers

9.5 – 250 BHP

- ▶ Lower Fuel Costs & Emissions
- ▶ Simplified Installation
- ▶ Long Life & Low Maintenance



**ALL MODELS:**  
328 – 8,625 lbs/h Output F&A 212°F  
ASME Section I & IV Designs



**Hydrogen  
READY**  
*Up to 20% Blend*

# SETTING A NEW STANDARD

Fulton is one of the largest boiler manufacturers in the world with 70+ years of experience and more than 100,000 boilers installed. Continuing this tradition of success, our dedicated Research and Development team has developed the VSRT® steam boiler to be the new standard for heavy-duty industrial applications.

## Long Life & Low Maintenance

Fulton's exclusive stress-relieving architecture beats the competition in every category of durability. The thick-walled, low-stress design creates steam rapidly from a cold start with no low-fire warm up period required.

- ▶ Fully Water-Backed & Refractory-Free
- ▶ Easily Adapts to Changing Loads
- ▶ Industry Leading Warranties



## Lowest Cost of Ownership

Over a 20 year span, the majority of owner investment is spent on operational costs such as fuel and boiler maintenance.

The VSRT features a best-in-class efficiency and the longest boiler life expectancy in the world to provide customers the lowest possible total cost of ownership.

## Lower Fuel Costs & Emissions

VSRT boilers reduce operating costs by 20% and provide leading efficiencies without the use of an external economizer. Each boiler is equipped with linkageless controls and variable speed blowers as standard. Cycling is minimized with high turndown low NOx burners, increasing boiler life.

- ▶ Efficiency up to 86%
- ▶ NOx Emissions Below 9 ppm
- ▶ Up to 10:1 Turndown Burner

## Simplified Installation

Reduce installation cost and time with a compact vertical design which occupies less than half the floor space of conventional designs. VSRT boilers do not require a second ASME steam valve or flue gas recirculation line to achieve low emissions.

- ▶ Reduce Footprint by 50% or More
- ▶ Approved for Sealed Combustion
- ▶ Smaller Stack Diameters

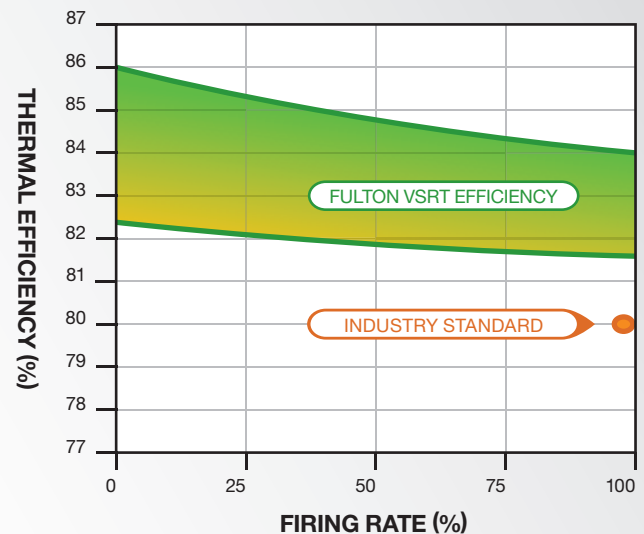

# A REVOLUTION IN STEAM BOILER DESIGN

Fulton's patented spiral rib heat exchanger achieves industry leading heat transfer rates. The unique spiral design provides a long heat transfer path which is optimized to achieve maximum heat transfer in a compact space.

The VSRT features a fully water backed pressure vessel wrapped with high-density insulation, resulting in minimal thermal losses and low jacket temperatures.



**A** Air/fuel mixture enters into the combustion chamber

**B** PURE optimized burner features turndown up to 10:1 with exceptionally low NOx emissions

**C** Combustion gases transition downward from the combustion chamber into the spiral heat exchanger

**D** Flue gases spiral through Fulton's patented spiral rib heat exchanger

# SPECIFICATIONS & DIMENSIONS

	MODEL	VSRT-9.5	VSRT-10	VSRT-15	VSRT-20	VSRT-30	VSRT-40	VSRT-50	VSRT-60	VSRT-80	VSRT-100	VSRT-125	VSRT-250
<b>SPECIFICATIONS</b>													
Fuel Input	MBH	385	400	600	800	1,200	1,600	1,993	2,392	3,200	4,000	4,999	9,800
Steam Output, F&A 212°F	LB/HR	328	345	518	690	1,035	1,380	1,725	2,070	2,760	3,450	4,313	8,625
Output	MBH	318	335	503	670	1,005	1,340	1,674	2,008	2,678	3,348	4,185	8,370
Turndown Ratio		8:1	4:1	6:1	4:1	6:1	6:1	8:1	10:1	10:1	10:1	10:1	10:1
<b>DIMENSIONS</b>													
Height w/o Trim	IN	76	70	70	79	79	97	97	97	110	125	125	144
Height w/ Trim	IN	86	77	77	86	86	107	107	107	121	140	140	148
Height w/ Burner Pull	IN	100	99	99	111	110	130	130	130	144	140	140	148
Width w/o Trim	IN	24	33	33	33	33	49	49	49	49	63	62.75	86
Width w/ Trim	IN	40	57	57	61	60	68	68	68	71	75	75	101
Depth	IN	36	53	53	59	62	83	83	83	84	100	100	133
Steam Outlet (150 PSI, NPT)	IN	1	1	1	2	2	4	4	4	4	4	4	6
Air Inlet	IN	4	4	4	6	6	6	6	6	8	8	8	14
Flue	IN	6	6	6	8	8	10	10	10	12	10	10	14
<b>WEIGHTS</b>													
Shipping Weight	LBS	1,850	2,900	2,900	3,400	3,400	6,000	6,000	6,000	6,700	11,600	11,600	23,600
Operating Weight	LBS	1,920	3,500	3,500	4,100	4,100	7,864	7,864	7,864	9,080	18,975	18,975	34,894
Flooded Weight	LBS	2,000	3,850	3,850	4,400	4,400	8,600	8,600	8,600	9,710	19,925	19,925	37,513

*NOTE: Specifications and dimensions are approximate and for reference only. Fulton practices continuous product improvement and reserves the right to change specifications and/or dimensions without notice.*

## ENGINEERED SOLUTIONS

Fulton can design and build a system tailored to your specific needs. Be a part of the process, from concept to delivery, ensuring timely and accurate completion of your engineered system.

- ▶ Industry Leader in Systems Engineering
- ▶ Single-Source Turnkey Systems
- ▶ Wide Range of Ancillary Equipment

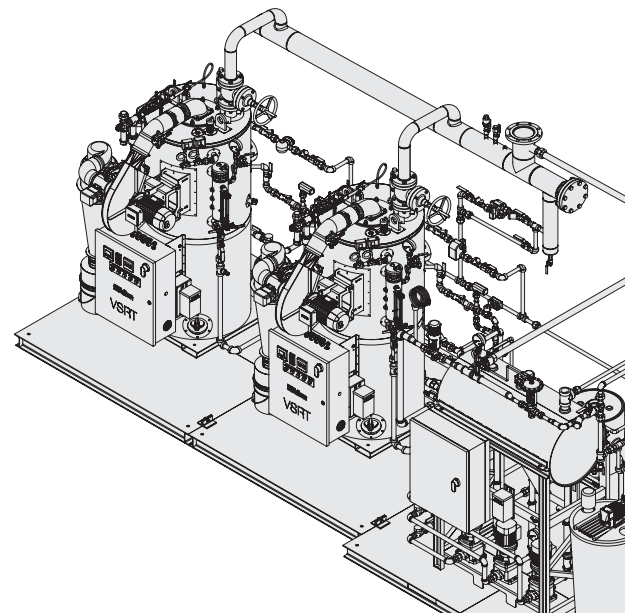

Call: (315) 298-5121

972 Centerville Road  
Pulaski, NY 13142



[fulton.com/vsrt](http://fulton.com/vsrt)

VSRT\_BROCHURE\_231214