

# SPECIFICATIONS & DIMENSIONS

MODEL FB:	012L	015L	018L	024L	030L	036L	050L	075L	100L	150L	200L	300L	500L	750L	1000L	
<b>SPECIFICATIONS</b>																
Unit Size	kW	12	15	18	24	30	36	50	75	100	150	200	300	500	750	1,000
	HP	1.2	1.5	1.8	2.4	3	3.6	5	7.5	10	15	20	30	50	75	100
Steam Output*	LBS/HR	42	53	63	84	105	126	175	263	350	525	700	1050	1750	2625	3500
Element Count		1	1	1	2	2	2	2	3	4	6	4	4	7	10	14
<b>ELECTRICAL</b>																
240V / 3 Phase	Amps	32	40	47	61	76	90	124	184	244	364	485	725	1206	1808	2409
480V / 3 Phase	Amps	16	20	24	31	38	45	62	92	122	182	243	363	603	904	1205
575V / 3 Phase	Amps	14	17	20	26	32	38	52	77	102	152	203	303	504	755	1006
<b>DIMENSIONS</b>																
(A) Boiler Height	IN	36	36	36	36	36	36	56	56	56	58	59	75	76	94	94
(B) Height w/ Piping	IN	36	36	36	36	36	36	56	56	56	58	59	75	76	94	94
(C) Width Overall	IN	40	40	40	40	40	40	38	42	42	44	64	64	77	88	104
(D) Depth Overall	IN	35	35	35	35	35	35	34	41	41	47	58	60	71	92	92
(E) Boiler Diameter	IN	20	20	20	20	20	20	18	25	25	29	33	37	45	50	64

\* Steam output ratings at 212°F feedwater (0 PSIG)

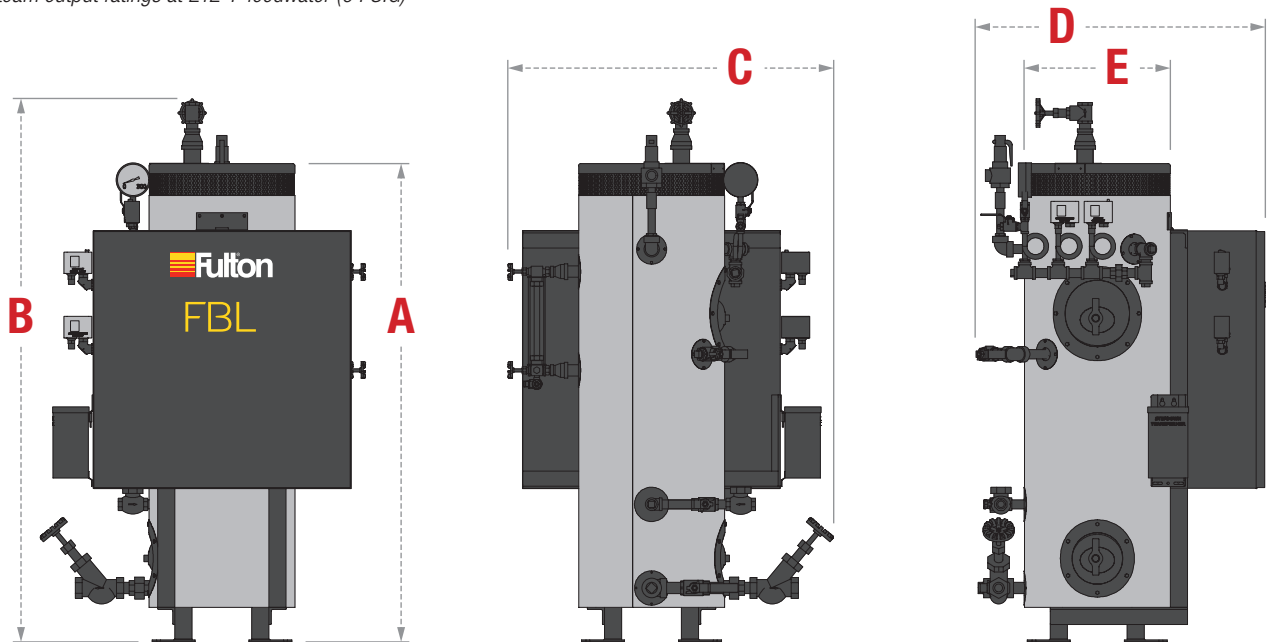

NOTE: Specifications and dimensions are approximate and for reference only. Fulton practices continuous product improvement and reserves the right to change specifications and/or dimensions without notice.



VIC: 03 8560 0419  
NSW: 02 9681 4177  
QLD: 07 3462 0159

SA: 08 8297 9688  
WA: 08 9455 5511  
tomlinsonenergy.com.au