



FB-W

Electric Hot Water Boilers

12 – 1000 kW

1.2 – 100 BHP



- ▶ Nearly 100% Efficient
- ▶ Zero Emissions
- ▶ Quiet and Safe
- ▶ No On-Site Combustion

Our electric boilers feature fully-insulated pressure vessels for minimal radiation losses, and our signature rugged design. The FB-W is a clean-running, combustion-free boiler for your hot water needs.



EFFICIENT, QUIET, SAFE OPERATION

Fulton manufactures a complete line of electric hot water boilers from 12 kW to 1,000 kW (1.2 to 100 BTU/Hr) and pressure ratings up to 160 PSI, perfect for heating and process applications.

Fulton's vertical design is a fully packaged hot water boiler built to ASME specifications and applicable standards and codes. The very efficient heating elements are totally immersed in water and the pressure vessel is fully insulated which keeps radiation losses at a minimum. Electric boilers are environmentally friendly and emit no NOx (nitrogen oxides) into the atmosphere.

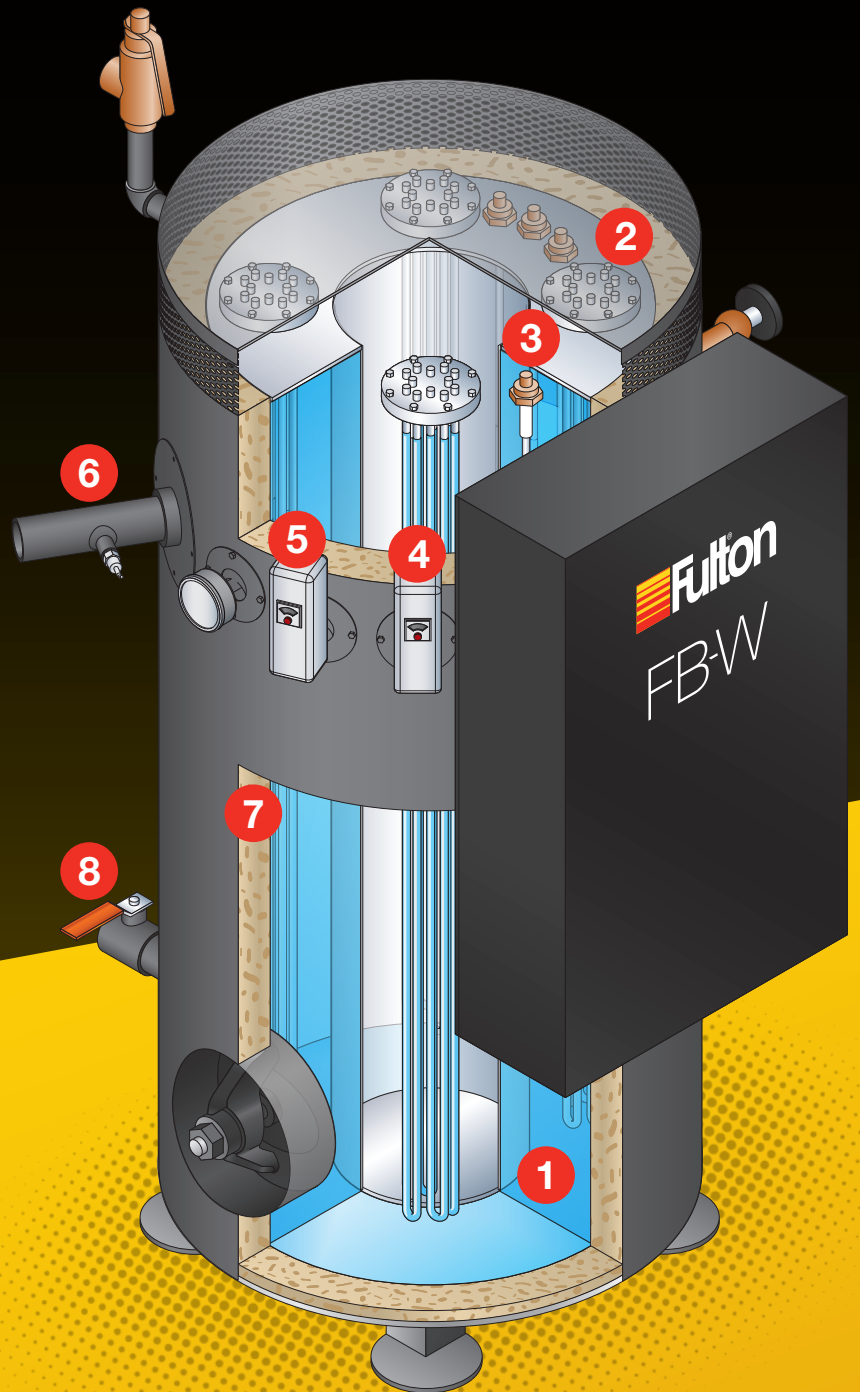

BETTER BY DESIGN

A LOOK INSIDE:

- 1** Pressure Vessel Is Built To ASME Code
- 2** Electric Heating Elements
- 3** Low Water Cut Off Probe
- 4** High Limit Temperature Control
- 5** Operating Temperature Control
- 6** Hot Water Supply Connection
- 7** High Temp Insulation Surrounds the Vessel
- 8** Hot Water Return Connection

SPECIFICATIONS AT A GLANCE

MODEL: FB-W (Hot Water)		12	15	18	24	30	36	70	105	140	175	210	280	350	420	490	560	630	700	1000
SPECIFICATIONS																				
Unit Size	kW	12	15	18	24	30	36	70	105	140	175	210	280	350	420	490	560	630	700	1000
	HP	1.2	1.5	1.8	2.4	3	3.6	7	10.5	14	17.5	21	28	35	42	49	56	63	70	100
	kBTU/hr	41	51	61	82	102	123	239	358	478	597	717	955	1194	1433	1672	1911	2150	2388	3412
DIMENSIONS																				
Number of Elements		(1) 12 kW	(1) 15 kW	(1) 18 kW	(2) 12 kW	(2) 15 kW	(2) 18 kW	(2) 35kW	(3) 35kW	(4) 35kW	(5) 35kW	(6) 35kW	(4) 70kW	(5) 70kW	(6) 70kW	(7) 70kW	(8) 70kW	(9) 70kW	(10) 70kW	(14) 72kW
(A) Height of Boiler Only	IN	22 5/8	22 5/8	22 5/8	22 5/8	22 5/8	22 5/8	55 3/4	54 3/8	54 3/8	54	54	53 5/16	53 5/16	55 7/8	56 7/8	56 7/16	60	57	79
	MM	575	575	575	575	575	575	1416	1397	1397	1372	1372	1354	1354	1422	1448	1448	1524	1448	2007
(B) Height w/ Piping	IN	35	35	35	35	35	35	61 1/8	60	59 1/2	59 1/2	59 1/2	58 5/16	58 5/16	65 1/8	64 1/4	65	61	88	93 3/16
	MM	889	889	889	889	889	889	1551	1524	1511	1511	1511	1481	1481	1653	1632	1651	1550	2235	2367
(C) Boiler Diameter	IN	20	20	20	20	20	20	17	24 1/8	24 1/8	28 1/8	28 1/8	36 1/4	36 1/4	40 1/8	44 1/8	44 1/4	50 1/4	51	63 1/4
	MM	508	508	508	508	508	508	432	613	613	715	715	921	920	1019	1121	1124	1277	1296	1607
(D) Overall Depth	IN	37 1/8	37 1/8	37 1/8	37 1/8	37 1/8	37 1/8	36 1/8	42 15/16	42 15/16	48 1/8	48 1/8	63 1/8	63 1/8	72	78 3/4	72	76	84	92
	MM	942	942	942	942	942	942	916	1091	1091	1223	1223	1602	1602	1829	2000	1829	1931	2134	2337
(E) Boiler Width Overall	IN	26 1/8	26 1/8	26 1/8	26 1/8	26 1/8	26 1/8	34 3/4	34 3/4	35 1/8	35 3/8	35 3/8	51 1/4	48	52	60	52	60	84	72
	MM	662	662	662	664	664	664	883	883	891	894	894	1302	1219	1321	1524	1321	1524	2134	1829
ELECTRICAL POWER																				
240V / 3 Phase	Amps	32	40	47	61	76	90	172	256	340	425	509	677	845	1014	1182	1351	1519	1687	2409
480V / 3 Phase	Amps	16	20	24	31	38	45	86	128	170	212	255	339	423	507	591	676	760	844	1205
575V / 3 Phase	Amps	15	17	20	26	32	38	72	107	142	177	213	283	353	423	494	564	634	705	1006

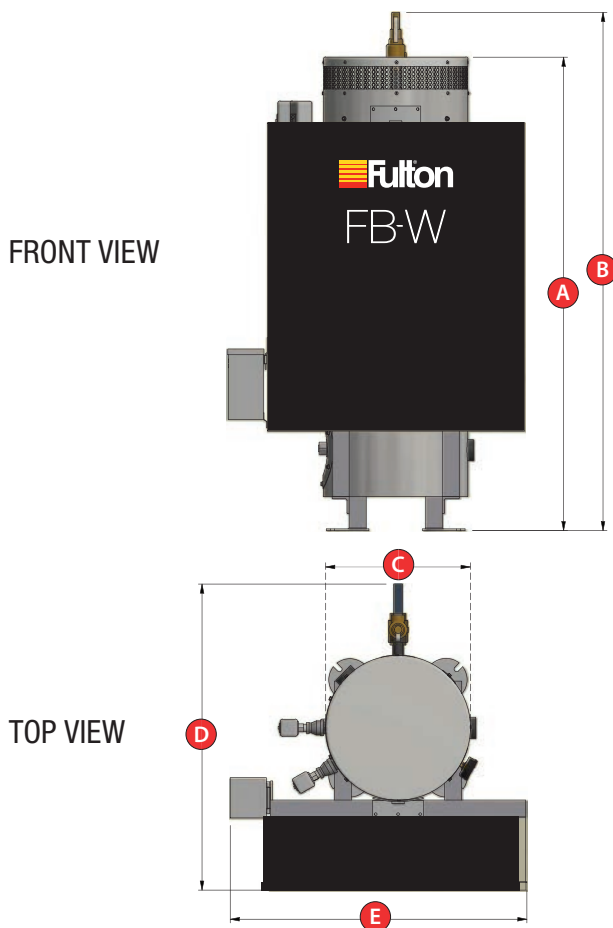

Specifications and Dimensions are approximate. We reserve the right to change specifications and/or dimensions without notice. Voltage applied higher than above ratings will result in higher amp draws.

Notes: * Indicates voltages may be available at special request.

OPTIMIZE YOUR BOILER SYSTEM

Fulton has been a family owned manufacturer of heat transfer equipment since 1949. Our FB-W boilers are available through a worldwide network of authorized representatives available to assist you in the selection of Fulton equipment to best meet your application needs.



ENGINEERED SOLUTIONS

Fulton can design and build a system tailored to your specific needs. Be a part of the process, from concept to delivery, ensuring timely and accurate completion of your engineered system.

- ▶ Industry Leader in Systems Engineering
- ▶ Single-Source Turnkey Systems
- ▶ Wide Range of Ancillary Equipment

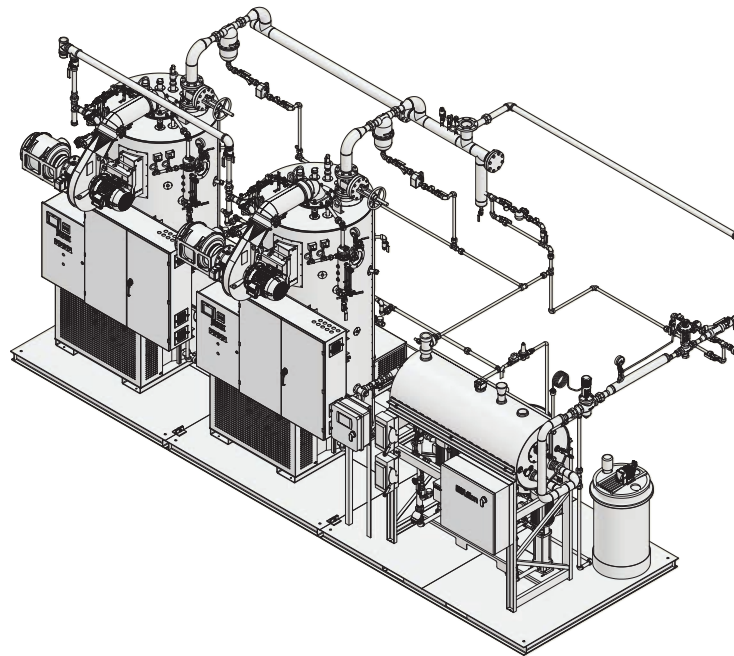

VIC: 03 8560 0419
NSW: 02 9681 4177
QLD: 07 3462 0159

SA: 08 8297 9688
WA: 08 9455 5511
tomlinsonenergy.com.au

