

– weishaupt –

product

Information on gas, oil, and dual-fuel burners



WM 50 for gas, oil, and dual-fuel

WM 50 monarch® burners (800–11 000 kW) • powerful and versatile

Progress and tradition: The latest monarch[®] burner



The monarch[®] trademark has stood for power and quality for more than 60 years

For more than six decades, Weishaupt's monarch[®] series burners have been used on a wide variety of heat generators and industrial plant, and their success has helped underpin Weishaupt's outstanding reputation.

The latest monarch[®] series is writing the next chapter in this success story. The combination of state-of-the-art equipment and a compact design makes these powerful burners suitable for a wide range of applications.

Digital.

Digital combustion management for economical and reliable burner operation. The equipment is simple to use.

Compact.

The aerodynamic housing and special air feed enable a higher capacity within smaller dimensions.

Powerful.

The latest monarch® burner's compact monobloc housing provides a lot of power, thanks to the specially developed fan unit.



Digital

Digital combustion management means optimal combustion figures, continuously reproducible setpoints, and ease of use.

Weishaupt WM 50-series burners are equipped as standard with electronic compound regulation and digital combustion management. Modern combustion technologies demand a precise and continually reproducible dosing of fuel and combustion air. This optimises combustion efficiency and saves fuel.

Simple operation

Setting and control of the burner is achieved using a control and display unit. This is linked to the combustion manager via a bus system, enabling the user-friendly setting of the burner.

Flexible communication options

The integrated interface enables all necessary data and functions to be relayed to a master control system. If required, a modem can be installed to allow for remote operation, monitoring, and diagnosis.

Bus communication with external controls and building management

Several bus systems are available if data from the burner are to be exchanged with a PLC unit, or if control of the burner is to be integrated with a building management system.

For the control and management levels, Weishaupt offers ProGraf NT, a real-time software product that meets any and all requirements.

Technological edge

Digital combustion management makes burner operation simple and reliable. The most important advantages:

- No additional burner controls are necessary as control is effected by the combustion manager. The only additional requirements are a motor protection switch for the burner motor and external control fuses.
- Reduced installation expense. Each burner is factory tested and supplied as a complete unit.
- Commissioning and servicing takes less time. The burner's basic parameters are set at the factory. The combustion manager's menu-driven commissioning program is used to run through the final site-specific adjustments and the combustion emission checks.

Digital combustion management Features	W-FM 100	W-FM 200
Single-fuel operation	●	●
Dual-fuel operation	●	●
Continuous firing >24 h	●	●
Variable speed drive available	–	●
O ₂ trim available	–	●
Combined O ₂ /CO control	–	○
Flame sensor for intermittent firing	ION/QRI/QRB/QRA	ION/QRI/QRB/QRA
Flame sensor for continuous firing	ION/QRI/QRA 73	ION/QRI/QRA 73
Maximum number of actuators	4	6
Gas valve proving	●	●
Integrated PID controller with automatic adaption. Pt / Ni temperature sensor, 0/2–10 V, and 0/4–20 mA inputs for temperature / pressure	○	●
Removable ABE control unit (max. length of connecting bus line)	100 m	100 m
Fuel consumption meter (switchable)	–	●
Combustion efficiency display in conjunction with O ₂ trim	–	●
eBUS / Modbus RTU interface	●	●
PC-supported commissioning	●	●

● Standard
○ Optional

Please enquire regarding connections available for additional functions, e.g. flue gas dampers, oil shutoff assemblies etc.

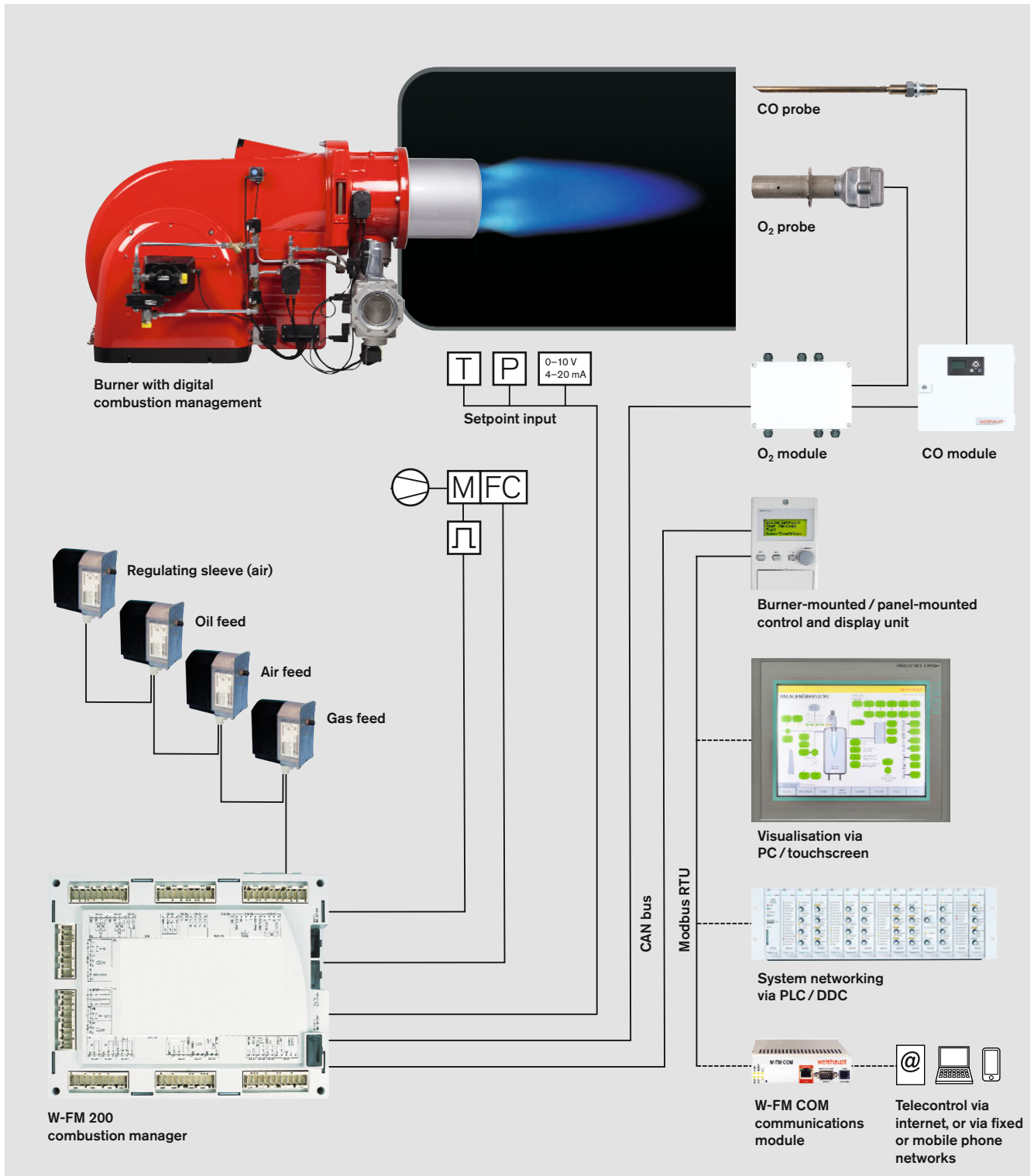

Schematic representation with W-FM 200

Compact and quiet

The latest Weishaupt WM-series monarch® burners are compact, powerful, and quiet. They are writing the next chapter in the 60-year-long success story of the legendary monarch® series.

Futuristic fan technology

From the very earliest stages of burner development, particular emphasis was placed on a compact, aerodynamic design and low operational noise levels.

To realise this goal a completely new air inlet and air damper control were developed. This special housing design with its self-opening air inlet and the new air-damper technology result in increased fan pressure and thus in greater capacity despite the burner's more compact form.

Air damper control provides a high degree of linearity even at the lower end of the burner's operating range and, combined with the sound-attenuated air inlet which is included as standard, ensures quieter operation.

Fast commissioning, simple servicing

All WM 50 burners are delivered with a modulating mixing assembly. A final adjustment is made using the combustion manager's menu-controlled commissioning program.

All of the burner's components, such as the mixing assembly, air damper, and combustion manager, are readily accessible despite its compact form. This enables maintenance and servicing work to be carried out quickly and easily, aided by the standard hinged flange which provides a perfect servicing position.

Adjustment to suit different combustion chamber conditions can easily be made with the burner in its installed position. The integral sightglass enables ignition behaviour and the flame to be observed.

Control

The following methods of regulation are available for Weishaupt WM 50 burners:

Gas: Sliding-two-stage or modulating (ZM), depending on the method of load control employed.

Oil: Sliding-two-stage or modulating (R), depending on the method of load control employed.

The output of a modulating burner is matched – within its operating range – to current heat demand.

These multiple control options make the burner suitable for a wide range of applications and ensure a gentle and problem-free start up, along with a high degree of operational reliability.

NR version

Gas and dual-fuel burners with an advanced-design mixing assembly for installations with Class 2 (oil-side) and Class 3 (gas-side) NO_x emission limits.

Reduced NO_x emissions with flue gas recirculation (gas burners)

Where stringent emission limits for oxides of nitrogen are in force, Weishaupt's various mixing assemblies for gas-fired burners can be combined with flue gas recirculation. Weishaupt takes advantage of the special properties of the flame geometry, and with it the adaption to the combustion chamber, to reduce NO_x levels.

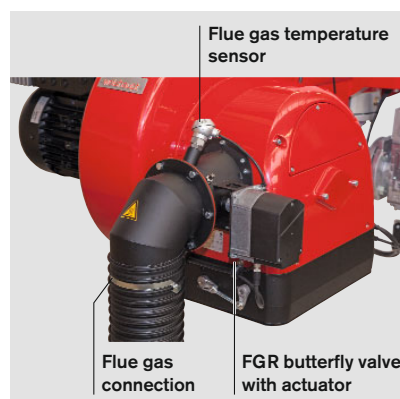

Air inlet housing with factory-preassembled flue gas recirculation components

Fuels

Natural gas

LPG

Light oil (35 s gas oil)

10 % biodiesel blends (B10)

The suitability of fuels of differing quality must be confirmed in advance with Weishaupt.

Applications

Weishaupt WM 50 burners are suitable for intermittent firing and continuous firing on:

- EN 303-compliant heat generators
- LTHW boilers
- HTHW boilers
- Steam boilers
- Air heaters
- Certain process applications

Permissible ambient conditions

- Ambient temperature
-15 to + 40 °C for gas firing
-10 to + 40 °C for oil firing
- Maximum 80 % relative humidity, no condensation
- The combustion air must be free of aggressive substances (halogens, chlorides, fluorides etc.) and impurities (dust, debris, vapours, etc.)
- Adequate ventilation is required for operation in enclosed spaces
- For plant in unheated areas, certain further measures may be required

Use of the burner for other applications or in ambient conditions not detailed above is not permitted without the prior written agreement of Max Weishaupt GmbH. Service intervals will be reduced in accordance with the more extreme operational conditions.

Protection Class

IP 54 per EN 60529.

Standards compliance

The burners are tested by an independent body and fulfil the applicable requirements of the following European Union directives and applied standards:

- EMC** EMC Directive
2014/30/EU
Applied standards:
- EN 61000-6-1 : 2007
 - EN 61000-6-2 : 2005
 - EN 61000-6-4 : 2007
- LVD** Low Voltage Directive
2014/35/EU
Applied standards:
- EN 60335-1 : 2010
 - EN 60335-2-102 : 2010
- MD** Machinery Directive
2006/42/EC
Applied standards:
- EN 267 Annex J,
 - EN 676 Annex J,
- GAD** Gas Appliance Directive
2009/142/EC
Applied standards:
- EN 676 : 2008
- PED¹⁾** Pressure Equipment Directive
2014/68/EU
Applied standards:
- EN 267 Annex K,
 - EN 676 Annex K,
 - Conformity assessment procedure: Module B

The burners are labelled with

- CE Mark,
- CE-PIN per 2009/142/EC
- Identification No. of the notified body

¹⁾ With the appropriate choice of equipment.

The most important advantages:

- Easy changeover between gas and oil on dual-fuel burners
- Digital combustion management with electronic compound regulation at all ratings
- Compact design
- Sound-attenuated air inlet as standard for quieter operation
- Powerful fan with specially developed fan geometry and air damper control
- All WM 50 burners are equipped with modulating mixing assemblies
- IP 54 protection as standard

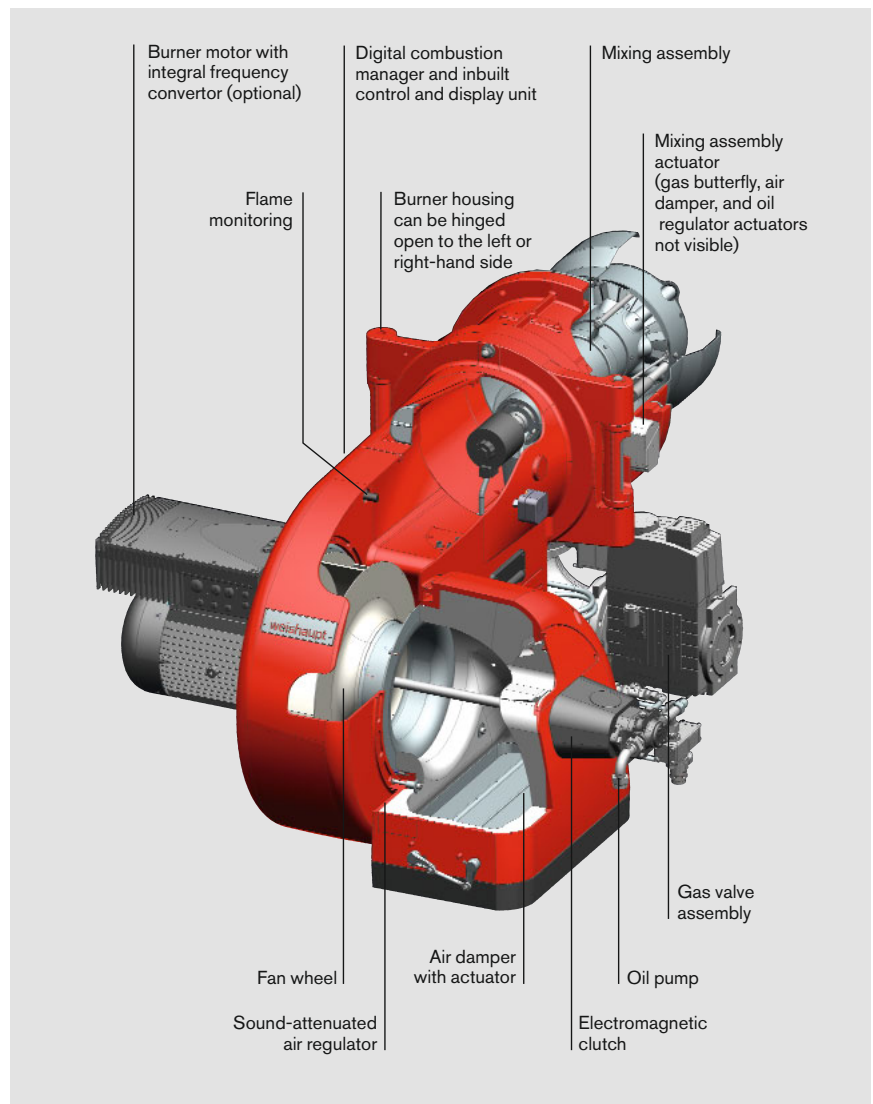

WM-GL 50, version ZM-R-NR

- Electromagnetic clutch included as standard (WM-GL50)
- Easy access to all components, such as the mixing assembly, air damper and combustion manager
- Reliable operation with sliding-two-stage or modulating operation, depending on the burner version and method of load control
- Computer-controlled function test of each individual burner at the factory
- Burners can be supplied with pre-wired plug connections
- Excellent price / capacity relationship

- Well-established, global service network

Trademark protection

Weishaupt WM 50 monarch® burners are registered as a Community Trade Mark throughout Europe.

Overview of burner regulation

Model designation

Oil-fired operation

Sliding-two-stage or modulating operation (R)

- On opening the solenoid valves the correct rate of oil for start up is released.
- An actuator sets the oil regulator to full load.
- Load control is achieved through the opening and closing of the oil regulator.
- Modulating operation:
 - W-FM 100 with load controller
 - W-FM 200
- Alternatively, a PID controller can be fitted into the control panel

Sliding-two-stage

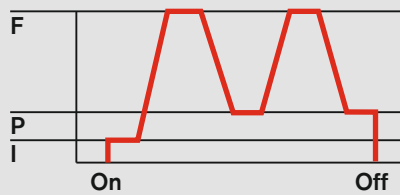

Modulating

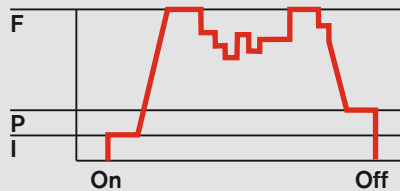

F = Full load (nominal load)
 P = Partial load (minimum load)
 I = Ignition load

Gas-fired operation

Sliding-two-stage or modulating operation (ZM)

- Actuators drive the burner to partial load or full load in response to heat demand.
- There is a gradual change between both load points. There are no sudden, large changes in fuel throughput.
- Modulating operation:
 - W-FM 100 with load controller
 - W-FM 200
- Alternatively, a PID controller can be fitted into the control panel

Fuel Version	Oil		Gas	
	sliding-two-stage	modulating	sliding-two-stage	modulating
ZM-NR			●	●
ZM-R-NR	●	●	●	●

Model designation

WM - L 50 / 2 -A R

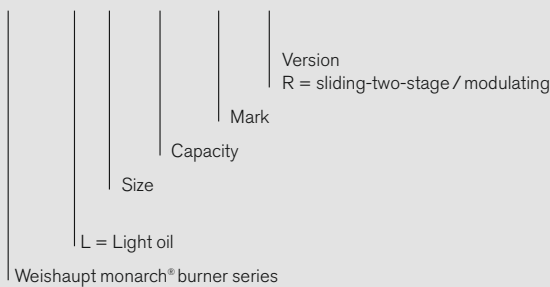

WM - GL50 / 2 -A ZM - R - NR

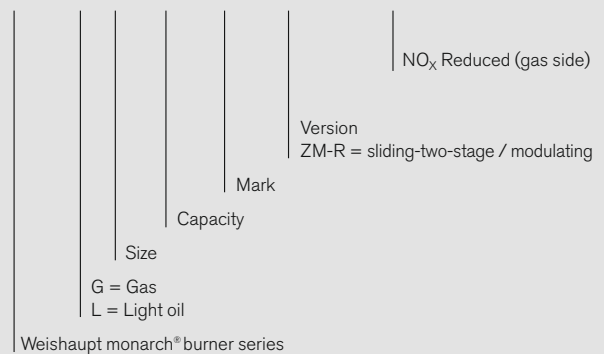

Burner selection WM-L50, version R

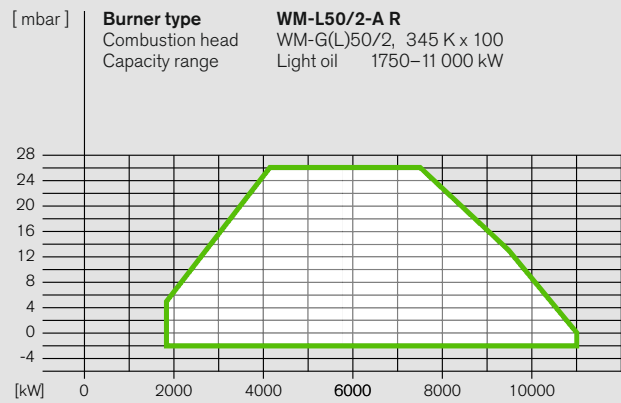
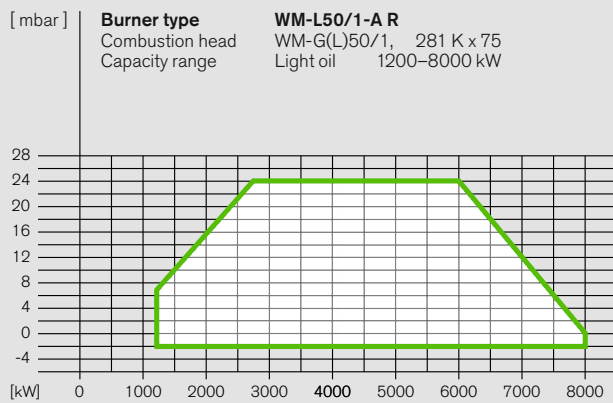

Turndown:
 Light oil max. 6:1

Capacity graphs for oil burners certified in accordance with EN 267.

Stated ratings are based on an air temperature of 20 °C and an installation altitude of 500 m above sea level.

Stated oil throughputs are based on a nett calorific value (LHV) of 11.9 kWh/kg.

DIN CERTCO certification:
 The burners have been type-tested by an independent body (TÜV-Süd) and certified by DIN CERTCO.

Burner selection

WM-G(L)50, versions ZM-NR and ZM-R-NR

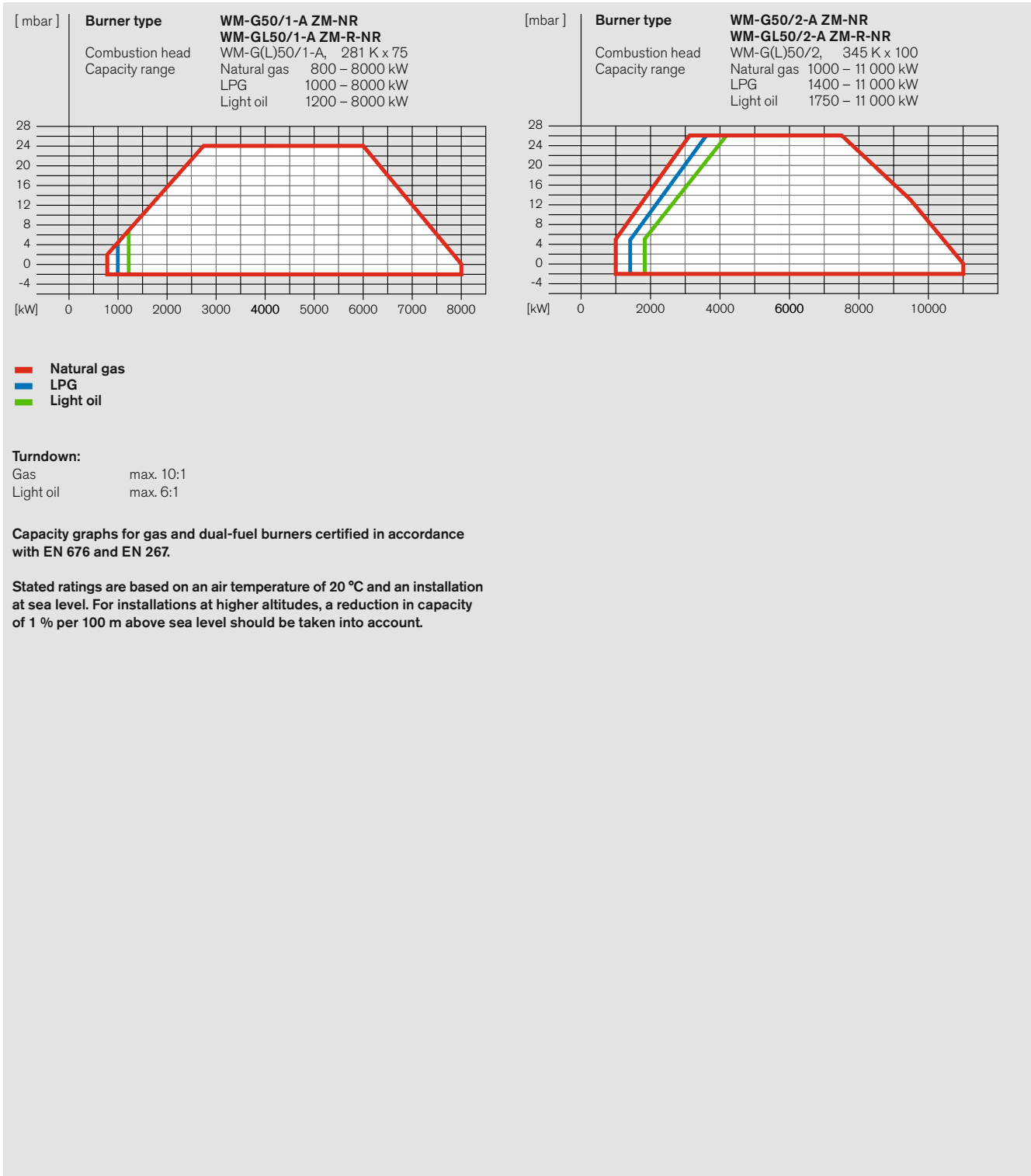

Gas valve train sizing

WM-G(L)50, versions ZM-NR and ZM-R-NR

WM-G(L)50/1-A, versions ZM-NR and ZM-R-NR

Burner rating kW	Low-pressure supply (with FRS) (flow pressure in mbar into shut-off valve, $P_1 \leq 300$ mbar)	High-pressure supply (with HP regulator) (flow pressure in mbar into gas valve assembly)
	Nominal valve train diameter 2" 65 80 100 125 150 Nominal diameter of gas butterfly 100 100 100 100 100	Nominal valve train diameter 2" 65 80 100 125 150 Nominal diameter of gas butterfly 100 100 100 100 100

Natural gas E	LHV = 10.35 kWh/Nm ³ ; d = 0.606											
4000	200	104	66	46	39	36	99	57	44	35	33	32
4500	245	122	75	49	41	37	118	64	48	36	33	32
5000	295	144	85	53	43	38	139	72	52	38	34	33
5500	-	168	97	59	46	41	162	82	57	41	36	35
6000	-	199	114	68	54	47	192	97	68	48	42	40
6500	-	232	133	79	62	54	-	113	78	55	49	46
7000	-	268	153	91	71	62	-	130	90	63	56	53
7500	-	-	174	103	80	70	-	148	103	72	63	60
8000	-	-	197	116	90	78	-	168	116	81	71	68

Natural gas LL	LHV = 8.83 kWh/Nm ³ ; d = 0.641											
4000	276	136	81	52	42	38	131	69	50	37	34	33
4500	-	163	94	57	45	40	158	79	56	39	35	33
5000	-	195	110	64	49	43	189	93	63	43	38	36
5500	-	235	132	76	59	50	-	111	76	51	45	42
6000	-	279	156	90	69	59	-	132	89	60	53	50
6500	-	-	182	104	80	68	-	154	104	70	61	58
7000	-	-	211	120	92	78	-	178	121	81	71	67
7500	-	-	241	137	105	89	-	-	138	93	81	77
8000	-	-	274	156	119	101	-	-	157	106	92	87

LPG*	LHV = 25.89 kWh/Nm ³ ; d = 1.555											
4000	101	62	46	38	35	34	58	41	36	32	31	31
4500	120	69	50	39	36	34	66	44	37	33	31	31
5000	140	78	54	41	37	35	74	47	39	33	32	31
5500	163	88	59	43	38	35	84	51	41	34	32	31
6000	189	100	65	46	40	37	96	56	44	36	34	33
6500	217	112	72	50	43	40	108	62	48	38	36	35
7000	248	126	79	54	46	42	122	68	52	41	38	37
7500	281	141	87	58	48	44	136	75	56	43	40	39
8000	-	157	95	62	51	46	152	82	61	46	42	41

* The LPG charts are based on propane, but may also be used for butane.

Screwed		Flanged	
R 2	DMV525/12	DN 65	DMV5065/12
		DN 80	DMV5080/12
		DN 100	DMV5100/12
		DN 125	VDG40.125
		DN 150	VDG40.150

Stated flow pressures are based on a combustion chamber resistance of 0 mbar. The combustion chamber pressure of the heat generator must be added to the figure determined from the above chart when sizing the gas valve train. Minimum flow pressure 15 mbar.

For low-pressure supplies, EN 88-compliant governors with safety diaphragms are used.

For high-pressure supplies, an EN 334-compliant high-pressure regulator should be selected from the following technical booklets:

- Regulators up to 4 bar, Print No. 83001202
- Regulators with safety devices, Print No. 83197902

Refer to the burner's rating plate for the maximum connection pressure.

WM-G(L)50/2-A, versions ZM-NR and ZM-R-NR

Burner rating kW	Low-pressure supply (with FRS) (flow pressure in mbar into shut-off valve, $P_1 \leq 300$ mbar)	High-pressure supply (with HP regulator) (flow pressure in mbar into gas valve assembly)
	Nominal valve train diameter 65 80 100 125 150 Nominal diameter of gas butterfly 100 100 100 100 100	Nominal valve train diameter 65 80 100 125 150 Nominal diameter of gas butterfly 100 100 100 100 100

Natural gas E	LHV = 10.35 kWh/Nm ³ ; d = 0.606										
5300	157	91	56	45	39	77	55	39	35	33	33
6000	192	108	62	48	41	91	61	41	36	34	34
6500	220	121	68	51	43	101	67	44	37	35	35
7000	254	140	77	58	48	117	77	50	43	40	40
7500	291	159	88	65	55	133	88	57	48	45	45
8000	-	180	99	73	61	151	99	64	54	51	51
9000	-	226	123	91	76	190	124	80	68	63	63
10000	-	278	151	111	92	-	153	97	82	77	77
11000	-	-	181	132	110	-	184	117	99	92	92

Natural gas LL	LHV = 8.83 kWh/Nm ³ ; d = 0.641										
5300	214	118	66	50	42	99	66	43	37	35	35
6000	267	144	78	57	47	120	78	49	41	38	38
6500	-	169	91	66	54	141	91	57	48	44	44
7000	-	195	104	76	62	163	105	66	55	51	51
7500	-	223	119	86	71	186	120	75	62	58	58
8000	-	252	134	97	79	-	136	84	70	66	66
9000	-	-	168	121	98	-	170	105	88	81	81
10000	-	-	205	147	119	-	-	128	107	99	99
11000	-	-	246	175	142	-	-	153	127	118	118

LPG*	LHV = 25.89 kWh/Nm ³ ; d = 1.555										
5300	84	57	42	37	35	49	40	34	32	31	31
6000	98	63	45	39	36	55	43	35	32	32	32
6500	109	69	47	40	37	59	45	36	33	32	32
7000	122	75	50	42	38	64	48	37	34	33	33
7500	137	83	54	44	40	71	52	39	36	35	35
8000	152	91	58	47	42	77	56	42	38	36	36
9000	186	108	66	53	47	92	65	47	42	40	40
10000	224	128	76	59	51	108	75	52	46	44	44
11000	265	149	86	66	56	125	85	58	50	48	48

Scope of delivery

Description	WM-L50 R	WM-G50 ZM-NR	WM-GL50 ZM-R-NR
Burner housing, hinged flange, housing cover, Weishaupt burner motor, air inlet housing, fan wheel, combustion head, ignition unit, ignition cable, ignition electrodes, combustion manager with control unit, flame sensor, actuators, flange gasket, limit switch on hinged flange, fixing screws	●	●	●
Digital combustion manager W-FM 100 W-FM 200	● ○	● ○	● ○
Valve proving via W-FM and pressure switch with electronic compound	-	●	●
Class A double gas valve assembly	-	●	●
Gas butterfly valve	-	●	●
Air pressure switch	○	●	●
Low gas pressure switch	-	●	●
Modulating mixing assembly	●	●	●
Actuators for compound regulation of fuel and air via W-FM: Air damper actuator Gas butterfly valve actuator Oil regulator actuator Mixing assembly actuator	● - ● ●	● ● - ●	● ● ● ●
Oil pressure switch in return	●	-	●
Oil pump fitted to burner	●	-	●
Oil hoses	●	-	●
2 oil solenoid valves, oil regulator, nozzle head with solenoid valve, preinstalled regulating nozzle and safety shutoff device	●	-	●
Electromagnetic clutch	○	-	●
Star-delta combination, fitted to motor	●	●	●
IP 54 protection	●	●	●

EN 676 stipulates that ball valves, gas filters, and gas pressure regulators form part of the burner supply (see Weishaupt accessories list). Please enquire or see the special equipment section of this brochure for further burner executions.

- Standard
- Optional

Order numbers

Oil burners, version R

Burner type	Version	Order No.
WM-L50/1-A	R	215 520 10
WM-L50/2-A	R	215 520 20

DIN CERTCO: 5G1054

Gas burners, version ZM-NR

Burner type	Version	Valve train size	Order No.
WM-G50/1-A	ZM-NR	R 2	217 520 13
		DN 65	217 520 14
		DN 80	217 520 15
		DN 100	217 520 16
		DN 125	217 520 17
		DN 150	217 520 18
WM-G50/2-A	ZM-NR	DN 65	217 522 14
		DN 80	217 522 15
		DN 100	217 522 16
		DN 125	217 522 17
		DN 150	217 522 18

CE-PIN: CE-0085 CP 0102

Dual-fuel burners, version ZM-R-NR

Burner type	Version	Valve train size	Order No.
WM-GL50/1-A	ZM-R-NR	R 2	218 520 13
		DN 65	218 520 14
		DN 80	218 520 15
		DN 100	218 520 16
		DN 125	218 520 17
		DN 150	218 520 18
WM-GL50/2-A	ZM-R-NR	DN 65	218 522 14
		DN 80	218 522 15
		DN 100	218 522 16
		DN 125	218 522 17
		DN 150	218 522 18

DIN CERTCO: 5G1055M

CE-PIN: CE-0085 CP 0102

Special equipment WM-L50, version R

Version R		WM-L50/1-A	WM-L50/2-A
Pressure gauge with ball valve on pump		110 002 82	110 002 82
Pressure gauge with ball valve in return		110 011 50	110 011 50
Vacuum meter with ball valve		110 017 00	110 017 00
Combustion head extension	by 150 mm	210 032 12	210 032 14
	by 300 mm	210 032 13	210 032 15
Air inlet flange for ducted-air connection, with LGW air pressure switch		210 032 24	210 032 24
LGW 50 air pressure switch ¹⁾		210 031 39	210 031 39
Integral load controller and analogue signal convertor for W-FM 100		110 017 18	110 017 18
W-FM 100 supplied loose		210 032 08	210 032 08
W-FM 200 in lieu of W-FM 100 with integral load controller, analogue signal convertor, and VSD module, with optional fuel metering	burner-mounted	210 032 09	210 032 09
	supplied loose	210 032 10	210 032 10
DSB 158 oil pressure switch in supply ¹⁾		210 031 09	210 031 09
QRI flame sensor in lieu of QRB ¹⁾		210 030 24	210 030 24
VSD with integral frequency convertor (W-FM 200 required)		250 033 94	250 033 95
VSD with separate frequency convertor (W-FM 200 required) (See accessories list for frequency convertor)		250 033 97	250 033 98
W-FM 200 with extended O ₂ trim / CO control functionality		Please enquire	Please enquire
ABE with Chinese-character display, supplied loose		110 018 53	110 018 53
Special voltage (on application only)		Please enquire	Please enquire
110 V control voltage		250 031 72	250 031 72

Country-specific executions and special voltages on application

¹⁾ Required for PED (2014/68/EU) compliance.

Special equipment WM-G50, version ZM-NR

Version ZM-NR		WM-G50/1-A	WM-G50/2-A
Combustion head extension	by 150 mm	250 034 02	250 034 03
	by 300 mm	250 034 04	250 034 05
Solenoid valve for air pressure switch test with continuous-run fan or post-purge		250 030 21	250 030 21
High gas pressure switch ¹⁾ (Screwed DMV for low-pressure supplies)	GW 50 A6/1	250 033 30	250 033 30
	GW 150 A6/1	250 033 31	250 033 31
	GW 500 A6/1	250 033 32	250 033 32
High gas pressure switch ¹⁾ (Flanged DMV / VGD for low-pressure supplies)	GW 50 A6/1	150 017 49	150 017 49
	GW 150 A6/1	150 017 50	150 017 50
	GW 500 A6/1	150 017 51	150 017 51
High gas pressure switch ¹⁾ (Fitted to high-pressure regulator)	GW 50 A6/1	250 033 33	250 033 33
	GW 150 A6/1	250 033 34	250 033 34
	GW 500 A6/1	250 033 35	250 033 35
Air inlet flange for ducted-air connection, with LGW air pressure switch		210 032 24	210 032 24
W-FM 100 supplied loose		210 032 08	210 032 08
Integral load controller & analogue signal convertor for W-FM 100		110 017 18	110 017 18
W-FM 200 in lieu of W-FM 100 with integral load controller, analogue signal convertor, and VSD module with optional fuel metering	burner-mounted	210 032 09	210 032 09
	supplied loose	210 032 10	210 032 10
VSD with integral frequency convertor (W-FM 200 required)		250 033 93	250 033 94
VSD with separate frequency convertor (W-FM 200 required) (See accessories list for frequency convertor)		250 033 97	250 033 97
W-FM 200 with extended O ₂ trim / CO control functionality		250 033 78	250 033 78
Offset gas butterfly valve and gas valve assembly for vertical firing		250 034 32	250 034 32
ABE with Chinese-character display, supplied loose		110 018 53	110 018 53
110 V control voltage		250 031 72	250 031 72
Flue gas recirculation (must be sized by factory)		250 034 69	250 034 69

Country-specific executions and special voltages on application

¹⁾ Required for PED (2014/68/EU) compliance.

Special equipment

WM-GL50, version ZM-R-NR

Version ZM-R-NR		WM-GL50/1-A	WM-GL50/2-A
Combustion head extension	by 150 mm	250 034 06	250 034 07
	by 300 mm	250 034 08	250 034 09
Solenoid valve for air pressure switch test with continuous-run fan or post-purge		250 030 21	250 030 21
High gas pressure switch ¹⁾ (Screwed DMV for low-pressure supplies)	GW 50 A6/1	250 033 30	250 033 30
	GW 150 A6/1	250 033 31	250 033 31
	GW 500 A6/1	250 033 32	250 033 32
High gas pressure switch ¹⁾ (Flanged DMV / VGD for low-pressure supplies)	GW 50 A6/1	150 017 49	150 017 49
	GW 150 A6/1	150 017 50	150 017 50
	GW 500 A6/1	150 017 51	150 017 51
High gas pressure switch ¹⁾ (Fitted to high-pressure regulator)	GW 50 A6/1	250 033 33	250 033 33
	GW 150 A6/1	250 033 34	250 033 34
	GW 500 A6/1	250 033 35	250 033 35
Air inlet flange for ducted-air connection, with LGW air pressure switch		Please enquire	Please enquire
Integral load controller & analogue signal converter for W-FM 100		110 017 18	110 017 18
DSB 158 oil pressure switch in supply ¹⁾		210 031 09	210 031 09
W-FM 100 supplied loose		210 032 08	210 032 08
W-FM 200 in lieu of W-FM 100 with integral load controller, analogue signal converter, and VSD module with optional fuel metering	burner-mounted	210 032 09	210 032 09
	supplied loose	210 032 10	210 032 10
VSD with integral frequency converter (W-FM 200 required) ²⁾		250 033 94	250 033 95
VSD with separate frequency converter (W-FM 200 required) ²⁾ (See accessories list for frequency converter)		250 033 97	250 033 98
W-FM 200 with extended O ₂ trim / CO control functionality		250 033 78	250 033 78
Offset gas butterfly valve and gas valve assembly for vertical firing		250 034 32	250 034 32
ABE with Chinese-character display, supplied loose		110 018 53	110 018 53
110 V control voltage		250 031 72	250 031 72

Country-specific executions and special voltages on application

¹⁾ Required for PED (2014/68/EU) compliance.

²⁾ VSD with ZM-R-NR version burners: General conditions for modulating capacity regulation when firing on oil
 – Frequency: min. 35 Hz
 – Turndown: max. 5:1

Technical data

Oil burners

Oil burners		WM-L50/1-A	WM-L50/2-A
Burner motor ¹⁾	Weishaupt type	WM-D160/240-2/16K5	WM-D160/240-2/21K0
Motor power output	kW	16.5	21
Nominal current	A	34	41
Motor protection switch ²⁾ or motor prefusing ²⁾	Type (e.g.) A minimum	PKE65/XTU-65 50 A gG / T (by others)	PKE65/XTU-65 63 A gG / T (by others)
Speed (50 Hz)	rpm	2940	2960
Combustion manager	type	W-FM 100	W-FM 100
Flame monitoring	type	QRB	QRB
Oil actuator	type	SQM45	SQM45
Air damper / mixing assembly actuator	type	SQM48	SQM48
NO _x Class per EN 267		2	2
Mass	kg	455	470
Integral pump	type	T3	T3
Max. flow rate	l/h	2060	2060
Oil hoses	DN / length	25 / 1300	25 / 1300

¹⁾ The electrical motors are premium-efficiency IE3 motors in accordance with Commission Regulation (EC) No. 640/2009

²⁾ The necessary motor protection can be provided either by a motor protection switch (supplied and fitted into a panel by others), or with integral motor overload protection (see special equipment).

Voltages and frequencies:

The burners are equipped as standard for three-phase alternating current, 400 V, 3 ~, 50 Hz. Other voltages and frequencies are available on application.

Standard burner motor:

Insulation Class F, IP 55 protection.

Technical data

Gas and dual-fuel burners

Gas burners		WM-G50/1-A	WM-G50/2-A
Burner motor ¹⁾²⁾	Weishaupt type	WM-D 160/240-2/14K5	WM-D 160/240-2/19K0
Motor power output	kW	14.5	19
Nominal current	A	29	37
Motor protection switch ²⁾ or motor prefusing ²⁾	type (e.g.) A minimum	PKE 65/XTU-65 50 A gG / T (by others)	PKE 65/XTU-65 50 A gG / T (by others)
Speed (50 Hz)	rpm	2940	2960
Combustion manager	type	W-FM 100	W-FM 100
Flame monitoring	type	ION	ION
Gas actuator	type	SQM45	SQM45
Air damper / mixing assembly actuator	type	SQM48	SQM48
NO _x Class per EN 676		3	3
Mass (excl. gas valve assembly and fittings)	kg	415	430
Dual-fuel burners		WM-GL50/1-A	WM-GL50/2-A
Burner motor ¹⁾²⁾	Weishaupt type	WM-D 160/240-2/16K5	WM-D 160/240-2/21K0
Motor power output	kW	16.5	21
Nominal current	A	34	41
Motor protection switch ²⁾ or motor prefusing ²⁾	type (e.g.) A minimum	PKE 65/XTU-65 50 A gG / T (by others)	PKE 65/XTU-65 63 A gG / T (by others)
Speed (50 Hz)	rpm	2940	2960
Combustion manager	type	W-FM 100	W-FM 100
Flame monitoring	type	QRI	QRI
Gas / oil actuator	type	SQM45	SQM45
Air damper / mixing assembly actuator	type	SQM48	SQM48
NO _x Class per EN 267 / EN 676		2 / 3	2 / 3
Mass (excl. gas valve assembly and fittings)	kg	460	475
Integral pump	type	T3	T3
Max. flow rate	l/h	2060	2060
Oil hoses	DN / Length	25 / 1300	25 / 1300

¹⁾ The electrical motors are premium-efficiency IE3 motors in accordance with Commission Regulation (EC) No. 640/2009

²⁾ The necessary motor protection can be provided either by a motor protection switch (supplied and fitted into a panel by others), or with integral motor overload protection (see special equipment).

Voltages and frequencies:

The burners are equipped as standard for three-phase alternating current, 400 V, 3 ~, 50 Hz. Other voltages and frequencies are available on application.

Standard burner motor:

Insulation Class F, IP 55 protection.

Fuel systems

Gas-side fuel system

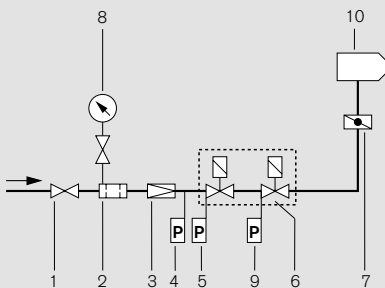

- 1 Ball valve *
- 2 Gas filter *
- 3 Pressure regulator, (LP) or (HP) *
- 4 High gas pressure switch *
- 5 Low gas pressure switch
- 6 Double gas valve assembly
- 7 Gas butterfly valve
- 8 Pressure gauge with push-button valve *
- 9 Valve-proving pressure switch
- 10 Burner

* Not included in burner price

Mounting position of the high gas pressure switch:
 On the regulator outlet of HP trains
 After the regulator of screwed LP trains
 On the valve assembly inlet of flanged LP trains
 Cable length approx. 2.5 m.

Layout of the valve train

On boilers with hinged doors, the valve train must be mounted on the opposite side to the boiler-door hinges.

Compensator

To enable a tension free mounting of the valve train, the fitting of a compensator is strongly recommended.

Break points in the valve train

Break points in the valve train should be provided to enable the door of the heat generator to be swung open. The main gas line is best separated at the compensator.

Support of the valve train

The valve train should be properly supported in accordance with the site conditions. See the Weishaupt accessories list for various valve train support components.

Gas meter

A gas meter must be installed to measure gas consumption during commissioning and servicing.

Optional thermal shutoff (when required by local regulations)

Integrated into the ball valve of screwed valve trains. A separate component with HTB seals fitted before the ball valve on flanged valve trains.

Oil-side fuel system

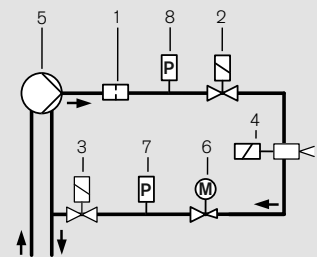

- 1 Strainer
- 2 Normally closed solenoid valve in supply
- 3 Normally closed solenoid valve in return
- 4 Nozzle head with regulating nozzle
- 5 Burner-mounted oil pump
- 6 Oil regulator
- 7 Pressure switch in return
- 8 Pressure switch in supply (optional)

Dimensions

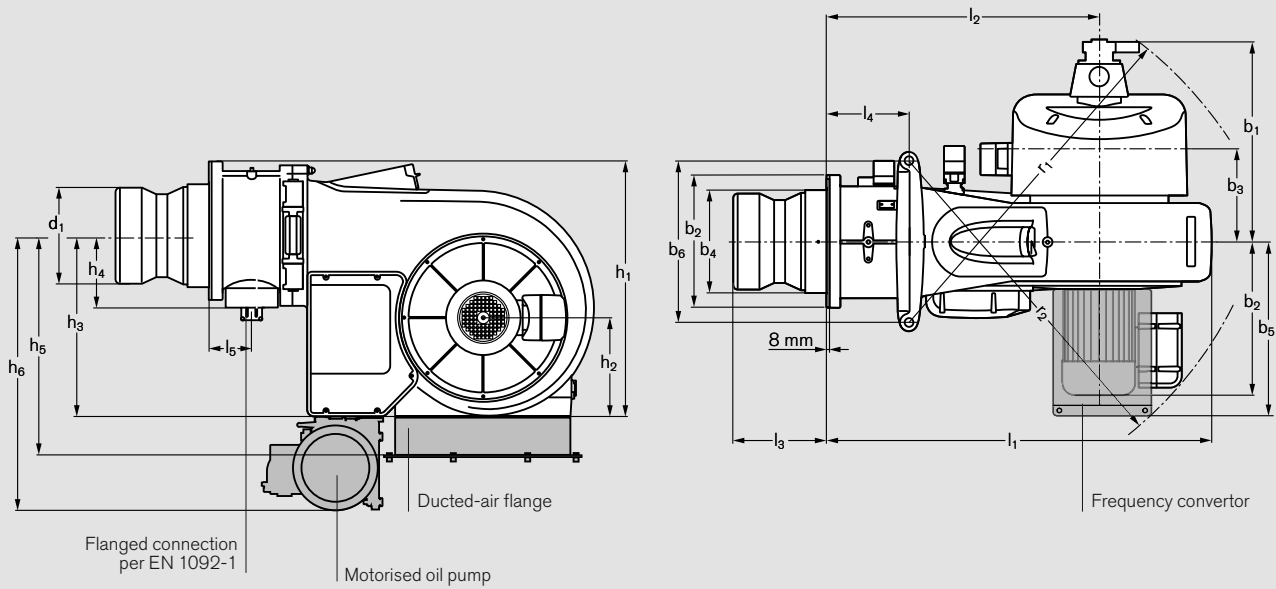

Optional

Burner type	Dimensions in mm													
	l_1	l_2	l_3	l_4	l_5	b_1	b_2	b_3	b_4	b_5	b_6	r_1	r_2^*	
WM-L50/1-A R	1616	1146	442	348	–	731	654	403	430	704	680	1467	1450	
WM-L50/2-A R	1636	1166	457	368	–	731	654	403	510	704	680	1467	1450	
WM-G50/1-A ZM-NR	1616	1146	442	348	178	629	654	403	430	704	680	1467	1450	
WM-G50/2-A ZM-NR	1616	1166	457	368	186	629	654	403	510	704	680	1467	1450	
WM-GL50/1-A ZM-R-NR	1616	1146	442	348	178	856	654	403	430	704	680	1533	1450	
WM-GL50/2-A ZM-R-NR	1636	1166	457	368	186	856	654	403	510	704	680	1533	1450	

All dimensions are approximate. Weishaupt reserve the right to make changes in light of future developments.

* Without frequency converter

Underside of ducted-air flange

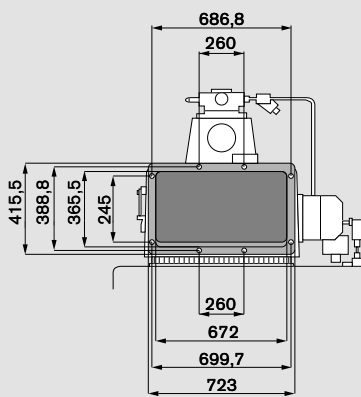

Mounting-plate drilling dimensions

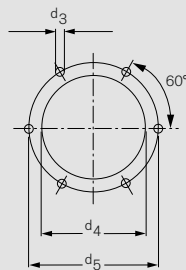

Heat generator preparation

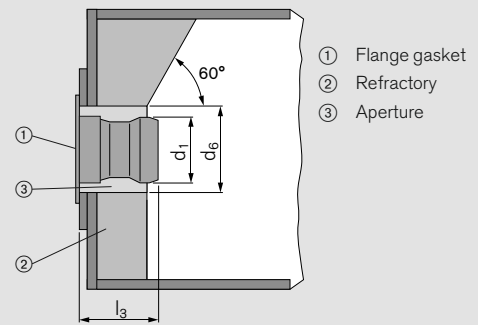

The refractory ② must not protrude beyond the front edge of the combustion head. It may, however, be tapered (min. 60°).

Burner type	Dimensions in mm												Nominal diameter of gas butterfly
	h_1	h_2	h_3	h_4	h_5	h_6	d_1	d_2	d_3	d_4	d_5	d_6	
WM-L50/1-A R	1058	414	758	–	854	980	403	520	M16	435	470	440	–
WM-L50/2-A R	1071	414	758	–	854	980	485	630	M16	530	580	530	–
WM-G50/1-A ZM-NR	1058	414	758	302	854	980	403	520	M16	435	470	440	DN100
WM-G50/2-A ZM-NR	1071	414	758	352	854	980	485	630	M16	530	580	530	DN100
WM-GL50/1-A ZM-R-NR	1058	414	758	302	854	980	403	520	M16	435	470	440	DN100
WM-GL50/2-A ZM-R-NR	1071	414	758	352	854	980	485	630	M16	530	580	530	DN100

All dimensions are approximate. Weishaupt reserve the right to make changes in light of future developments.

That's reliability



Boiler production in Sennwald



Neuberger building automation in Rothenburg



Borehole drilling by BauGrund Süd

The Weishaupt Group has over 3000 employees and is a market leader for burners, condensing boilers, heat pumps, solar energy, and building automation.

Since 2009 the business, which was founded in 1932, has been structured as a holding for three companies operating in the fields of energy technology, energy recovery, and energy management.

The core division is Max Weishaupt GmbH, which is located in the south-west German town of Schwendi, and which is where all burners are manufactured. It is also the group's

administrative headquarters, and home to the group's own Research and Development Institute.

Heating systems are manufactured by Weishaupt's sister company, Pyropac, which is located in the Swiss town of Sennwald.

Neuberger building automation, sited in Rothenburg ob der Tauber in Germany, has been a group subsidiary since 1995.

Germany's Bad Wurzach is home to the geothermal engineering company, BauGrund Süd, which has been part of the Weishaupt Group since 2009.



–weishaupt–



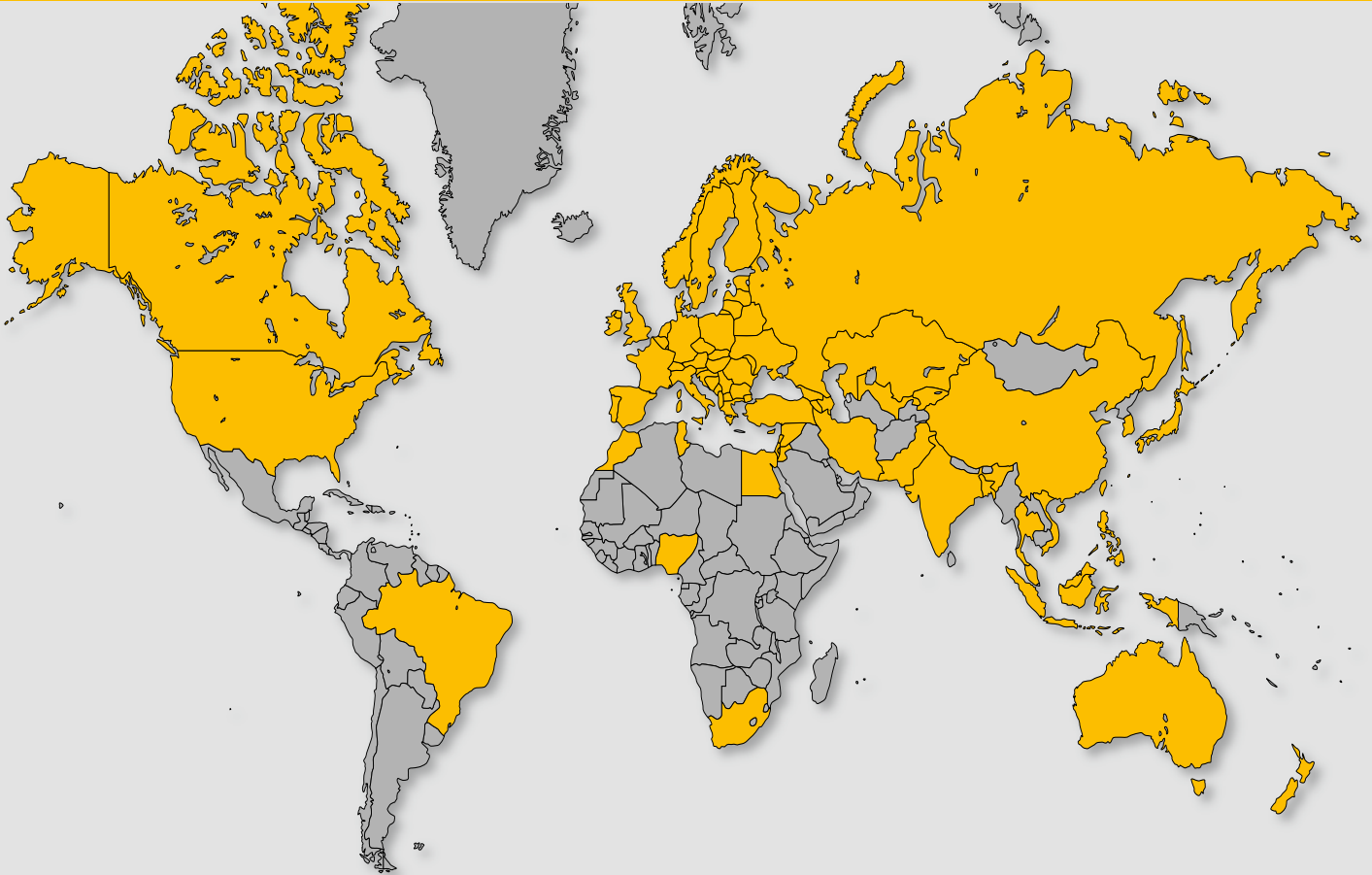

Weishaupt worldwide:

Branch offices across Germany and numerous subsidiary companies, representatives and agents across the world provide local support.

Germany:

Augsburg
Berlin
Bremen
Cologne
Dortmund
Dresden
Erfurt
Frankfurt
Freiburg
Hamburg
Hanover
Karlsruhe
Kassel
Koblenz

Leipzig

Mannheim
Munich
Münster
Neuss
Nuremberg
Regensburg
Reutlingen
Rostock
Schwendi
Siegen
Stuttgart
Trier
Wangen
Würzburg

Subsidiaries:

Belgium
Bosnia
Brasil
Canada
Croatia
Czech Republic
Denmark
France
Hungary
Italy
Poland
Romania
Serbia
Slovakia

Representation:

Slovenia
South Africa
Sweden
Switzerland (E)
United Kingdom
USA
Bulgaria
China
Lithuania
Algeria
Australia
Austria
Bangladesh

Cyprus

Egypt
Estonia
Finland
Greece
India
Indonesia
Iran
Ireland
Israel
Japan
Jordan
Korea (South)
Kuwait
Latvia

Lebanon

Luxembourg
Malaysia
Macedonia
Moldova
Morocco
Netherlands
New Zealand
Nigeria
Norway
Pakistan
Philippines
Portugal
Russia
Singapore

Spain

Switzerland (W)
Syria
Taiwan
Thailand
Tunisia
Turkey
Ukraine
UAE
Vietnam