

– weishaupt –

product

Information on gas, oil, and dual-fuel burners



WM 10 for gas, oil, and dual-fuel

WM 10 monarch® burners (55–1250 kW) • versatile performance

Progress and tradition: The latest monarch[®] burner



The monarch[®] trademark has stood for power and quality for more than 60 years

For more than six decades, Weishaupt's monarch[®] series burners have been used on a wide variety of heat generators and industrial plant, and their success has helped underpin Weishaupt's outstanding reputation.

The latest monarch[®] series is writing the next chapter in this success story. The combination of state-of-the-art equipment and a compact design makes these powerful burners suitable for a wide range of applications.

Digital.

Digital combustion management enables economical and reliable burner operation. The equipment is simple to use.

Compact.

The aerodynamic housing and special air feed enable a higher capacity within smaller overall dimensions.

Quiet.

WM 10 monarch burners operate with considerably reduced noise levels, thanks to their specially developed fan unit.

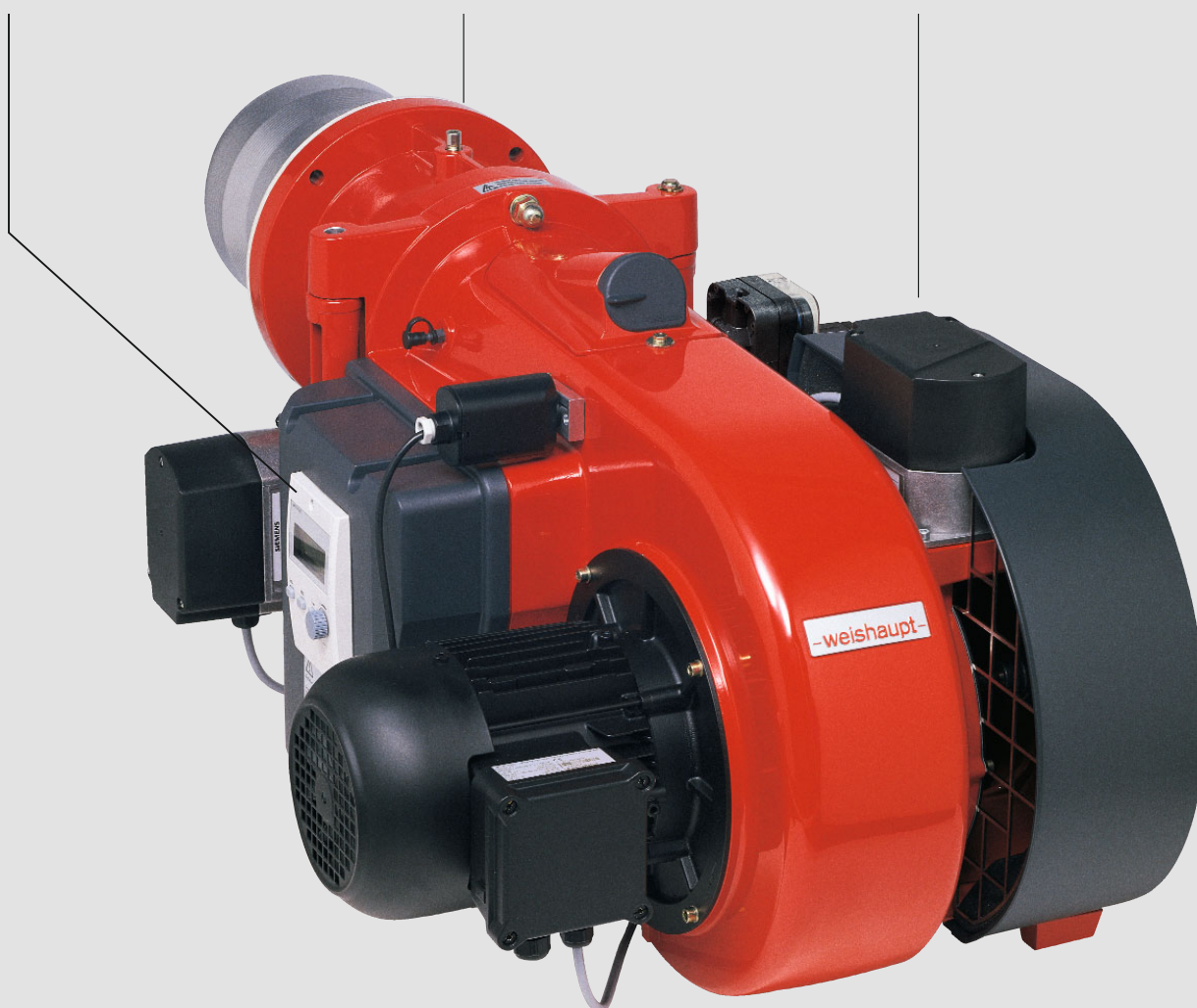

WM 10 monarch[®] burners

The right version for every application

The latest WM-series burners from Weishaupt are compact, powerful, and quiet. They are writing the next chapter in the 65-year-long success story of the legendary monarch[®] series.

Futuristic fan technology

From the very earliest stages of burner development, particular emphasis was placed on a compact, aerodynamic design and low operational noise levels.

A completely new air inlet and air damper control were developed to realise this goal. The special housing design with its self-opening air inlet and the new air-damper technology result in an increase in fan pressure and thus in greater capacity despite the burner's more compact form.

Air damper control provides a high degree of linearity even at the lower end of the burner's operating range and, combined with the sound-attenuated air inlet which is included as standard, ensures quieter operation.

Fast commissioning, simple servicing

All WM 10 burners are delivered with the mixing assembly preset for the required output of the burner, provided the relevant heat generator data are known. A final adjustment is made using the combustion manager's menu-controlled commissioning program.

All of the components, such as the mixing assembly, air damper, and combustion manager, are readily accessible despite the burner's compact form. This enables maintenance and servicing work to be carried out quickly and easily, aided by the standard hinged flange which provides a perfect servicing position.

Adjustments to suit different combustion chamber conditions can easily be made with the burner in its installed position. The integral sightglass provides a view of the flame.

Various burner versions are available, which meet differing operational requirements and emission limits:

ZM version

Burners with Weishaupt's standard, advanced design of mixing assembly for installations with Class 2 gas and oil-side NO_x emission limits.

LN version

Low-NO_x gas burners that provide a further improvement in NO_x emissions (to Class 3) compared to the standard mixing assembly. The reduction in NO_x is achieved through a more intensive recirculation of combustion gases in the combustion chamber.

Good emissions depend on combustion chamber geometry, thermal loading and on the combustion system (three-pass or reverse-flame).

ZMI version

Gas burners with an extended turndown range for special industrial applications.

3LN version

Low-NO_x gas, oil, and dual-fuel burners with multiflam[®] mixing assemblies that generate emissions below Class 3 NO_x limits for both gas and oil. The burners' very low NO_x emissions are achieved using a special fuel distribution system. 3LN-version burners can fire natural gas, LPG, or light oil, and are suitable for use on three-pass and through-pass boilers.

The most important advantages:

- Digital combustion management with electronic compound regulation.
- Compact design.
- Easy access to all components.
- Sound-attenuated air inlet as standard for quieter operation.
- IP 54 protection.
- Suitable for a wide range of gas types, such as natural gas, LPG, town gas, coke oven gas*, biogas*, or sewage gas* (*gas analysis required).
- Different mixing assemblies depending on emission limits.
- Suitable for operation with intermittent or continuous firing.
- Load control can be effected by means of thermostats, pressure controls, or current/voltage signals.
- Sliding-two-stage or modulating load control when firing on gas.
- Two-stage, three-stage, or sliding-two-stage / modulating load control when firing on oil, depending on the burner version and method of control.
- Where data are known, all WM-series burners are supplied with their mixing assembly preset for the required firing rate. WM-L burners are also supplied with ready-fitted oil nozzles.
- Electromagnetic clutch to disconnect the oil pump (optional extra on some models).
- Computer-controlled function test of each individual burner at the factory.
- Well-established, global service network.

Optional equipment:

- Variable speed drive for burners with modulating load control.
- Integral KS 20 load controller (in conjunction with W-FM50/54).
- Ducted air inlet.

Trademark protection

Weishaupt WM 10 monarch[®] burners are registered as a Community Trade Mark throughout Europe.

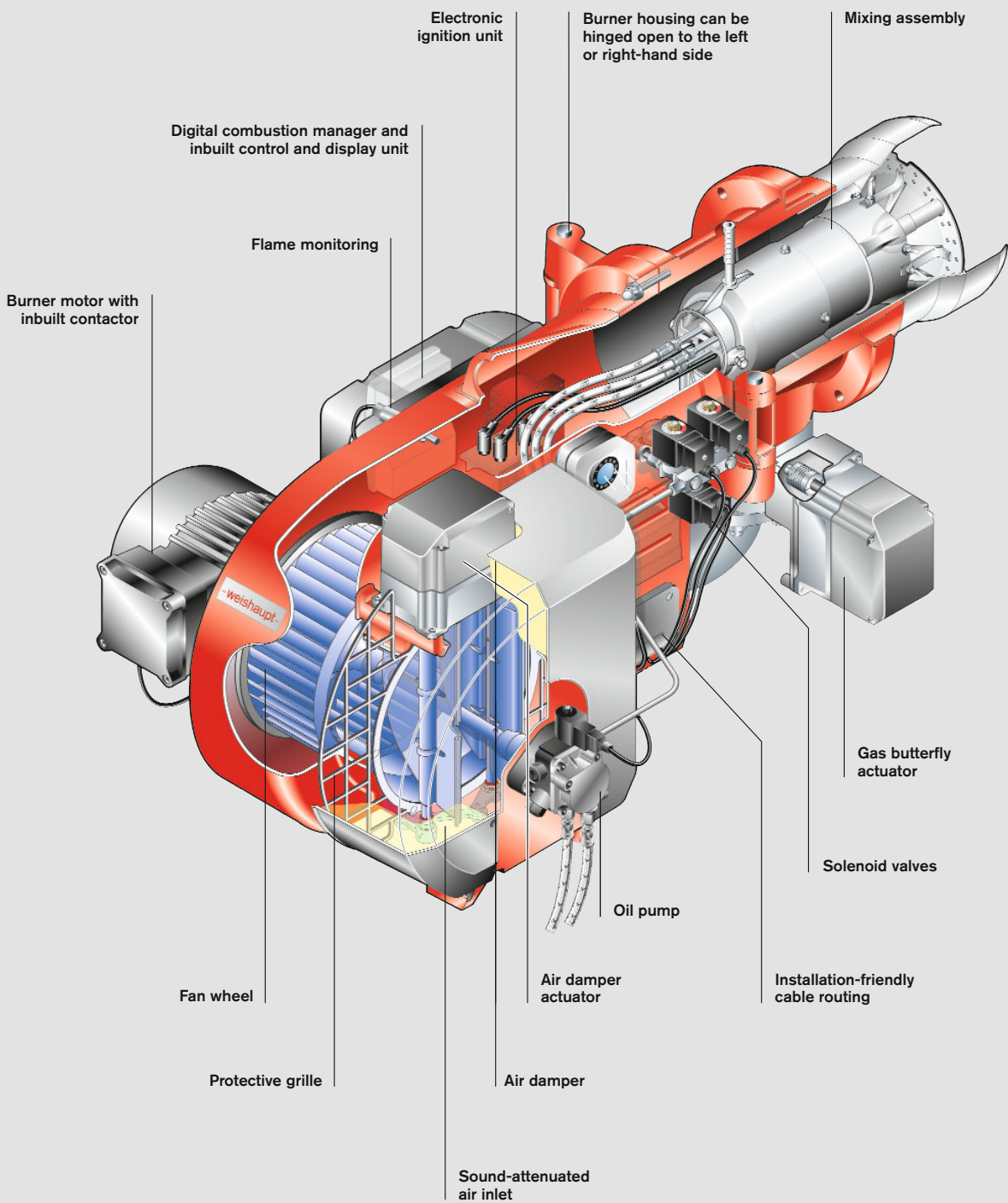

That's flexibility: Numerous options to choose from

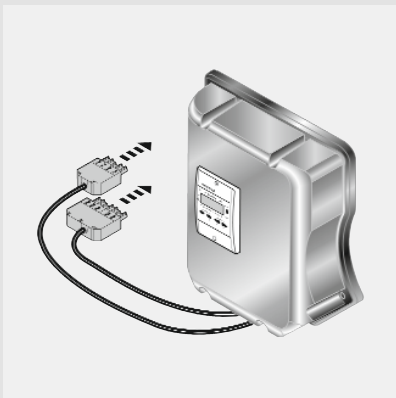

7-pole and 4-pole plugged connections



Integral KS20 load controller

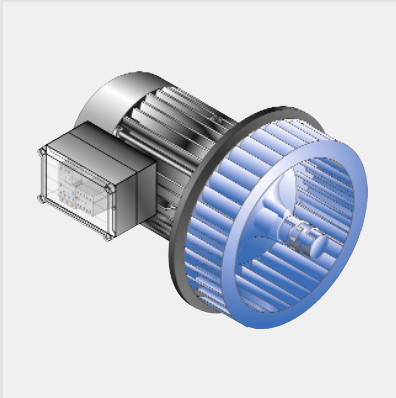

Expanded motor terminal box with contactor and electronic overload protection

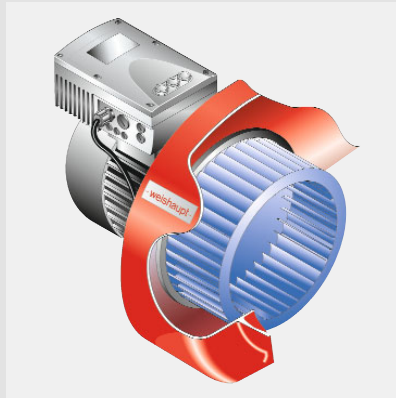

Integral frequency convertor for VSD

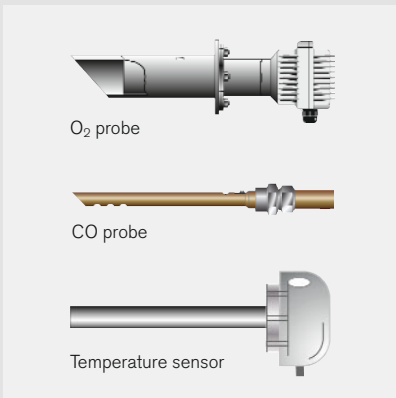

Monitoring and control of flue gases for O₂, CO, and temperature

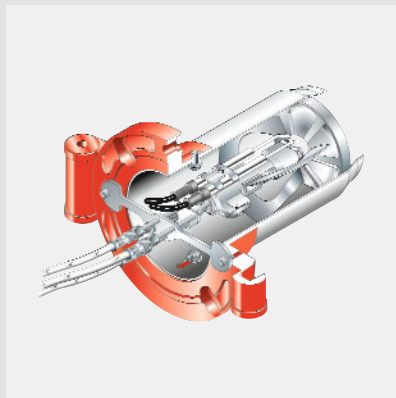

Combustion head extensions to suit different boiler doors and insulation

With the right selection of optional equipment, the best products can be made even better.

The familiar 7-pole and 4-pole plugs used on W-series burners can also be fitted to WM 10 burners, and many heat generators are equipped with the appropriate mating connectors. These optional plugs not only simplify the final connection of the control voltage, but also make it easy to electrically isolate the burners during servicing work.

Modulating burners need a load controller in order to modulate, and Weishaupt can fit one into the burner controls cover. The unit is pre-configured at the factory and supplied fitted and wired. An automatic adaption of the control parameters adjusts the controller to system characteristics.

The burner motor's large electrical junction box incorporates both a contactor and an overcurrent trip to protect the motor.

Optional efficiency, emissions, and safety optimisations are available for all industrial burners. Variable speed drive (VSD) offers a considerable reduction in energy costs and noise emissions when the burner is firing at partial load. O₂ trim and CO control increase both the safety and the efficiency of the plant. A flue gas temperature sensor indicates a limit value has been exceeded, which points to fouling of the heat generator.

Combustion head length is determined by the mounting depth of the heat generator, the design of the appliance, and the nature of the application. Standardised 100, 200, and 300 mm head extensions meet the requirements for virtually every project. Of course, longer extensions are available on request where necessary.

A continuously running fan stops high temperatures radiating back through the burner after firing has ended. During this phase, an electromagnetic clutch allows the oil pump to be disconnected from its drive. This has the benefit both of keeping the pump cool and reducing its wear. The burner motor's power consumption is also lower during the continuous fan phase.

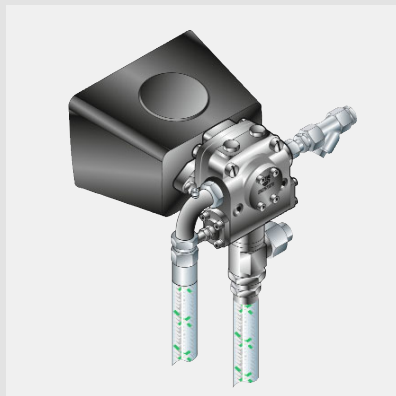

Oil burners with continuously running fan have an electromagnetic clutch

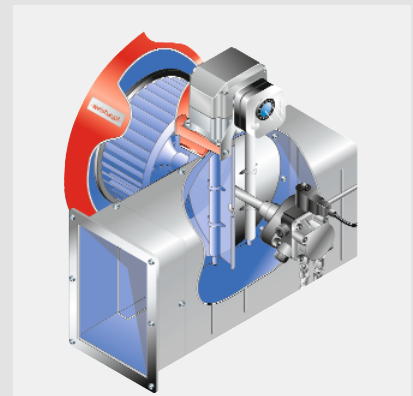

Air inlet connection for a ducted supply of clean air
Example: WM-L10

In many installations, a supply of clean combustion air that is free of impurities cannot always be guaranteed. To overcome this, Weishaupt offers special air inlet housings for the WM 10 that enable the connection of a ducted air supply. The housings enable the ducted air supply to be connected to the burner from above, below, or the rear. By connecting an air duct, it is possible to draw combustion air from a "clean", temperate area. The air inlet system includes an additional air pressure switch as standard, which guards against low pressure and thus ensures an adequate supply of air to the burner.



W-FM 100 or W-FM 200 combustion manager mounted in the burner



ACS 410/ACS 450 servicing software

The CAN bus system used by the W-FM 100 and W-FM 200 combustion managers means they can be mounted either on the burner or in a control panel. As a result, the installation is optimally matched to the ambient conditions on site.

Weishaupt sound-absorbing shrouds can reduce noise emissions by up to 25 dB(A), depending on the version employed. The typical 72 dB(A) sound pressure level of a WM-G10/1-A ZM-LN burner, for example, can be reduced to 47 dB(A) through the use of a sound absorbing shroud.

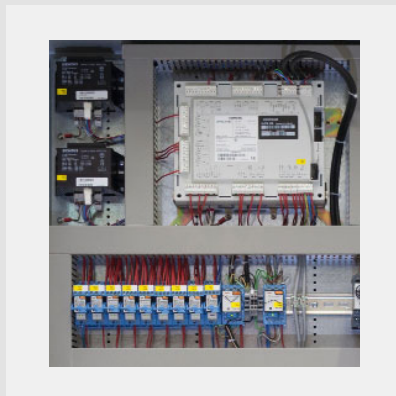

W-FM 100 or W-FM 200 combustion manager mounted in a control panel

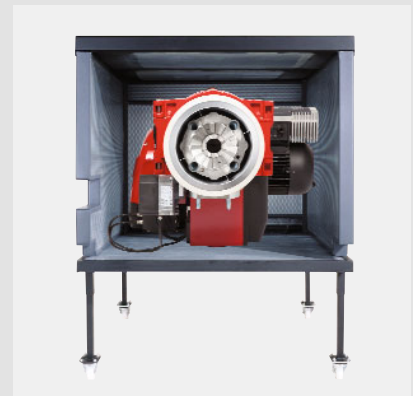

Sound-absorbing shroud

Digital combustion management: Efficient and reliable

Digital combustion management means optimal combustion figures, continuously reproducible setpoints, and ease of use.

Weishaupt WM 10-series burners are all fully equipped with digital combustion management and electronic compound regulation. Combustion technologies in the modern age demand a precise and continually reproducible dosing of fuel and combustion air. This enables optimal combustion efficiency and saves fuel.

Simple operation

Setting and control of the burner is achieved using a control and display unit. The unit for the W-FM50 and W-FM54 has a language-neutral display that presents all operationally relevant parameters in an easy-to-understand manner. The unit for the W-FM 100 and W-FM200 is equipped with a clear-text display with a choice of

languages. Both systems enable the precise setting of the burner, and retain data that provide information on the operational mode of the burner. Additional memory in the control and display unit stores system settings so that they can be quickly copied across to a new combustion manager.

Servicing software

Full documentation is an essential part of commissioning and servicing. Among other things, the servicing software provides access to combustion manager settings, which can be changed, saved, and printed out. That saves both time and money.

The most important advantages

- Digital combustion management makes burner operation simple and reliable.
- No additional burner controls are necessary as control is effected by the combustion manager.
- Reduced installation expense: Each burner is factory tested and supplied as a complete unit.
- Commissioning and servicing takes less time. The burner's basic parameters are set at the factory. The combustion manager's menu-driven commissioning program is used to run through the final site-specific adjustments and the combustion emission checks.

Digital combustion management Features	W-FM 50	W-FM 54	W-FM 100	W-FM 200
Single-fuel operation	●	–	●	●
Dual-fuel operation	–	●	●	●
Intermittent firing	●	●	●	●
Continuous firing >24 h	● ²⁾	–	●	●
Flame sensor for intermittent firing	ION/QRA2/QRB	QRA2	ION/QRI/QRB/QRA	ION/QRI/QRB/QRA
Flame sensor for continuous firing	ION	–	ION/QRI/QRA 73	ION/QRI/QRA 73
Maximum number of actuators in electronic compound	2	3	4	6
Actuators with stepping motors	●	●	●	●
VSD available	●	●	–	●
O ₂ trim available	–	–	–	●
Gas valve proving	●	●	●	●
4–20 mA input signal	●	●	Optional	●
Integrated, self-checking PID controller for temperature or pressure	–	Optional	●	
Removable ABE control unit (max. length of connecting line)	20 m	20 m	100 m	100 m
Fuel consumption meter (switchable)	● ¹⁾	● ¹⁾	–	●
Combustion efficiency display	–	–	–	●
eBUS/Modbus RTU interface	●	●	●	●
PC-supported commissioning	●	●	●	●

Please enquire regarding connections available for additional functions, e.g. flue gas dampers, oil shutoff assemblies, etc.

¹⁾ Not in conjunction with VSD

²⁾ Gas burner with ionisation probes only

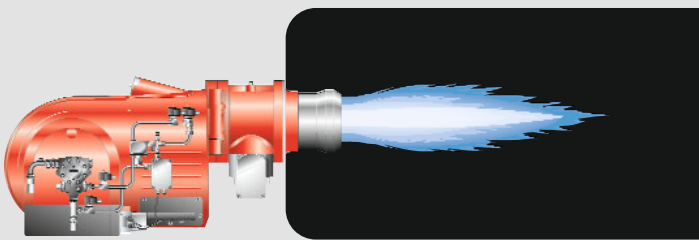

Burner with digital combustion management

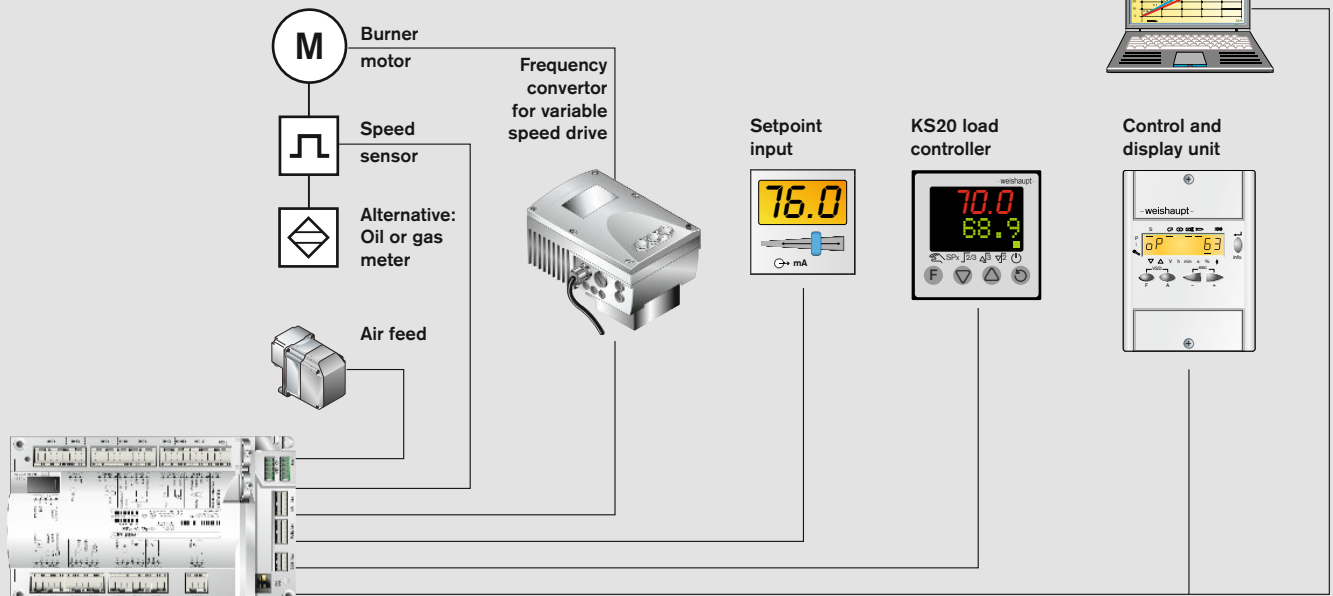

W-FM54 combustion manager and switching unit



Actuator, pressure switch, and valve switching

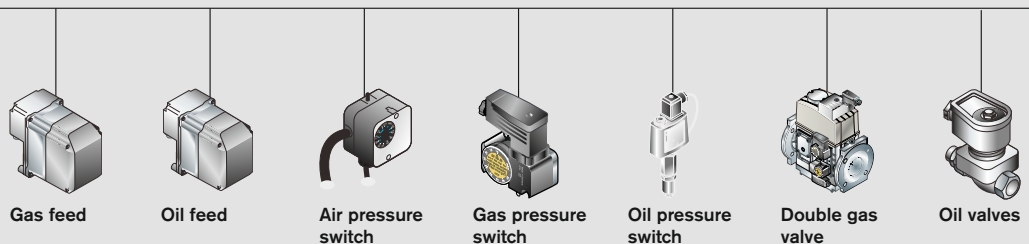

Schematic representation with W-FM54

Flexible communications: Compatible with building management systems

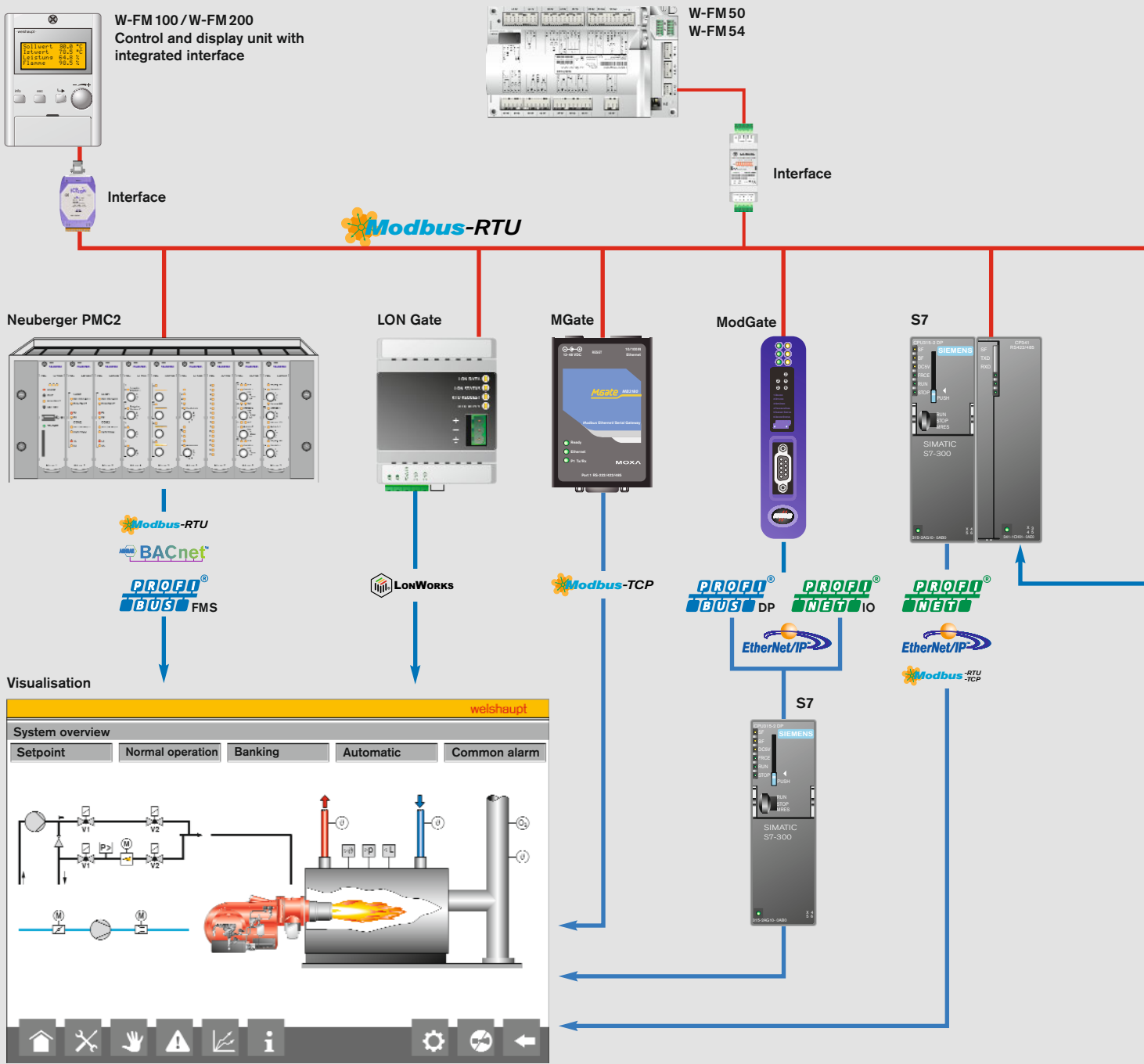



W-FM COM

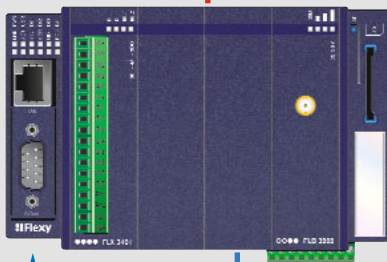

Communication
via the internet

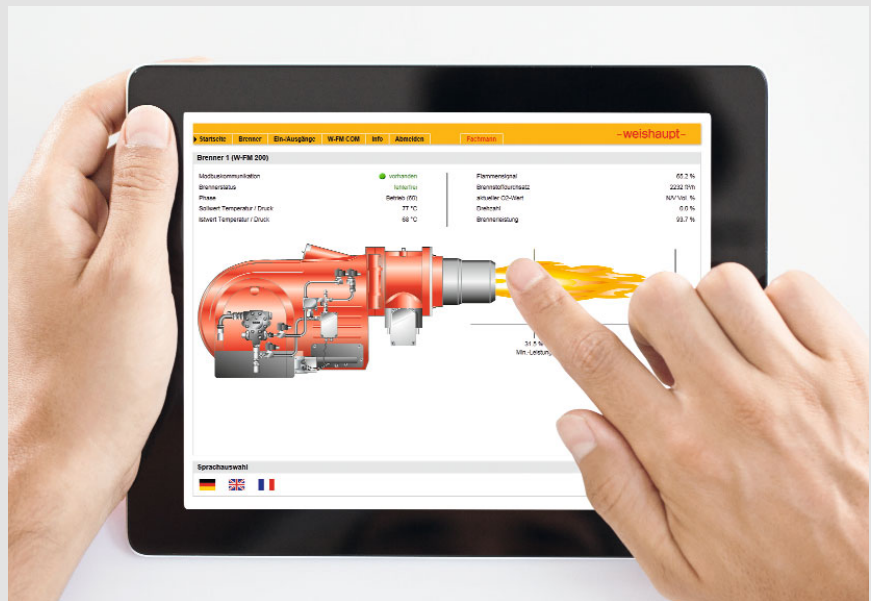

Remote monitoring made easy via tablet or laptop

The digital combustion manager is the basis of communications with other superordinate systems. This is generally achieved using the eBus or Modbus protocols.

All the usual burner and boiler functions can be monitored and controlled through a direct connection with a building management system.

A graphical HMI is available as an option to provide a user-friendly overview of the boiler. The touchscreen display allows numerous functions to be adjusted and monitored, such as system parameters and setpoints of individual and multi-boiler plant and ancillary equipment.

The controls specialists, Neuberger, who are a part of the Weishaupt Group, are able to design and implement complex control solutions.

Further optional components enable connections to be made to systems using commonplace industrial standards, such as Profibus-DP, LON-Bus, and Modbus-RTU, and via network protocols such as Profinet I/O, Modbus-TCP, BacNet, etc.

A recent addition to Weishaupt's portfolio is the W-FM COM communications module. It transmits data securely over the internet so that it can be called up and displayed in a browser window on a computer, tablet, or smartphone, facilitating accurate service planning for example. Even away from the internet you can be kept up to date with the operation of the burner: In the event of a safety shutdown or other predefined trigger, an SMS text message is sent automatically.

Overview of burner control

Model designation

Gas and oil-fired operation

Two-stage control (Z)

- Two-term switching (e.g. temperature or pressure stat) causes actuators to drive the burner to partial load or full load in response to heat demand. Single-stage control with low-impact start can also be effected.

Two-stage

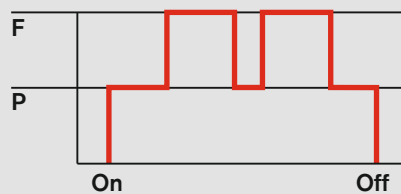

Control ¹⁾

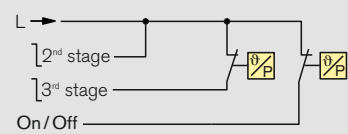

Three-stage control (T)

- Two-term switching (e.g. temperature or pressure stat) for each load point causes actuators to drive the burner to partial load, intermediate load, or full load in response to heat demand. Two-stage control with low-impact start or changeover can also be effected.

Three-stage

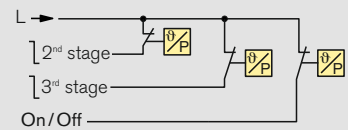
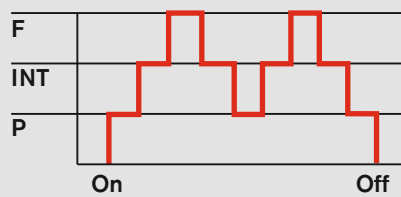

Sliding-two-stage control (ZM, R)

- Two-term switching (e.g. temperature or pressure stat) causes actuators to drive the burner to partial load or full load in response to heat demand. There is a gradual change between both load points. There are no sudden, large changes in fuel throughput.

Sliding-two-stage

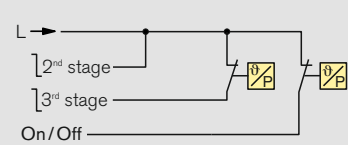
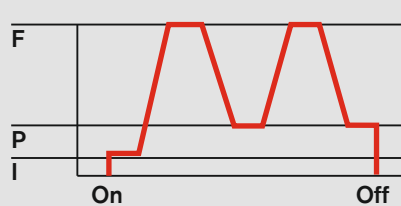

Modulating control (ZM, R)

- An electronic load controller causes actuators to make infinitely variable load adjustments in response to heat demand.
- Available modulation control options:
 - W-FM 100 with an optional integral load controller
 - W-FM 200 with its standard integral load controller
- Alternatively, a PID controller can be fitted into the burner controls cover or into a control panel.

Modulating

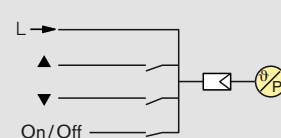
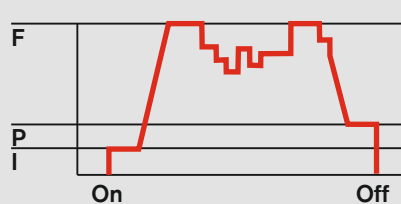

F = Full load (nominal load)
 INT = Intermediate load
 P = Partial load (minimum load)
 I = Ignition load

¹⁾ Alternatively, staged control can also be effected by an electronic PID controller. In this case, appropriate temperature sensors or pressure transducers will be required.

Model designation

WM-GL10/2-A

ZM-Z-3LN



Details	Code	Meaning	Associated fuel
Series	WM	Weishaupt monarch® burner	
Fuel *	G L	Gas Class D/Class A2 gas oil	
Load control *	Z T R ZM ZMI	Two-stage Three-stage Sliding-two-stage / modulating Sliding-two-stage / modulating ZM with extended turndown	Oil Oil Oil Gas Gas
Version	– LN 3LN	Standard Low-NO _x multiflam®	Gas / oil Gas Gas / oil

*) Dual-fuel burners use a combination of codes (GL, ZM-T, ZM-R).

Use

Fuels

Natural gas

LPG

Class D gas oil per BS 2869 / IS 251

Class A2 gas oil per BS 2869 / IS 251

10 % biodiesel blends (B10)

The suitability of fuels of differing quality must be confirmed in advance with Weishaupt.

Applications

Weishaupt WM 10 burners are suitable for intermittent firing and continuous firing on:

- EN 303-compliant heat generators
- LTHW boilers
- HTHW boilers
- Steam boilers
- Air heaters
- Certain process applications

Permissible ambient conditions

- Ambient temperature
 - 15 to + 40 °C for gas firing
 - 10 to + 40 °C for oil firing
- Maximum 80 % relative humidity, no condensation
- The combustion air must be free of aggressive substances (halogens, chlorides, fluorides etc.) and impurities (dust, debris, vapours, etc.)
- Adequate ventilation is required for operation in enclosed spaces
- For plant in unheated areas, certain further measures may be required

Use of the burner for other applications or in ambient conditions not detailed above is not permitted without the prior written agreement of Max Weishaupt GmbH. Burner service intervals will be reduced to accord with the more extreme operational conditions.

Protection Class

IP 54

Standards compliance

The burners are tested by an independent body and fulfil the applicable requirements of the following European Union directives and applied standards:

EMC

EMC Directive

2014/30/EU

Applied standards

- EN 61000-6-1 : 2007
- EN 61000-6-2 : 2005
- EN 61000-6-4 : 2007

LVD

Low-Voltage Directive

2014/35/EU

Applied standards

- EN 60335-1 : 2010
- EN 60335-2-102 : 2010

MD

Machinery Directive

2006/42/EC

Applied standards

- EN 267 Annex J,
- EN 676 Annex J,

GAR

Gas Appliances Regulation

2016/426/EU

Applied standards

- EN 676 : 2008

PED¹⁾

Pressure Equipment Directive

2014/68/EU

Applied standards

- EN 267 Annex K,
- EN 676 Annex K,
- Conformity assessment procedure: Module B

¹⁾ With the selection of appropriate equipment.

The burners are labelled with

- CE Mark
- CE-PIN per 2009/142/EC
- Identification No. of the notified body

Gas supply

EN 88-compliant regulators with safety diaphragms are used for low-pressure supplies.

For high-pressure supplies, an EN 334-compliant high-pressure regulator should be selected from the following technical booklets:

- Regulators up to 4 bar, Print No. 83001202
- Regulators with safety devices, Print No. 83197902

Refer to the burner's rating plate for the maximum connection pressure.

Gas valve train design

Low-pressure valve trains are normally used for gas flow pressures up to a maximum of 300 mbar and a maximum operating pressure (MOP) of 500 mbar. This allows for pressure losses between the transfer station and the valve train. Furthermore, it is assumed that the transfer station utilises components (SSV, regulator) that are not of the highest class of accuracy. In individual cases, following consideration and approval by Weishaupt's headquarters, a gas flow pressure of up to 360 mbar can be approved if the appropriate conditions exist. The supplier must safeguard the gas flow pressure such that it cannot exceed the MOP of the burner's gas valve train.

High-pressure valve trains are normally used for gas flow pressures greater than 300 mbar. The supplier must safeguard the gas flow pressure such that, in the event of failure, it cannot exceed the maximum incidental pressure (MIP*) of the burner's gas valve train.

*MIP = MOP x 1.1

Gas / dual-fuel burner capacity graphs

The capacities as a function of combustion chamber pressure are maximum values measured in accordance with EN 676 on idealised flame tubes.

The burner capacity graphs are certified in accordance with EN 676. The stated ratings are based on an air temperature of 20 °C and an installation at sea level. For installations at higher altitudes, a reduction in capacity of 1 % per 100 m above sea level should be taken into account.

The combustion chamber pressure of the heat generator must be added to the flow pressure determined from the chart when sizing the gas valve train. Minimum flow pressure 15 mbar.

The LHV is referenced to 0 °C and 1013 mbar atmospheric pressure. All pressures are in mbar.

The LPG charts are based on propane, but may also be used for butane.

Double gas valve assemblies

Screwed	
R ¾	W-MF507
R 1	W-MF512
R 1½	W-MF512
R 2	DMV525/12

Flanged	
DN 65	DMV5065/12
DN 80	DMV5080/12
DN 100	DMV5100/12

Oil burner capacity graphs

The capacities as a function of combustion chamber pressure are maximum values measured in accordance with EN 267 on idealised flame tubes.

The burner capacity graphs are certified in accordance with EN 267. The stated ratings are based on an air temperature of 20 °C and an installation altitude of 500 m above sea level. For installations at higher altitudes, a reduction in capacity of 1 % per 100 m above sea level should be taken into account.

Stated oil throughputs are for gas oil with a LHV of 11.9 kWh/kg.

DIN CERTCO certification

The burners have been type-tested by an independent body (TÜV-Süd) and certified by DIN CERTCO.

Modulating gas oil burner

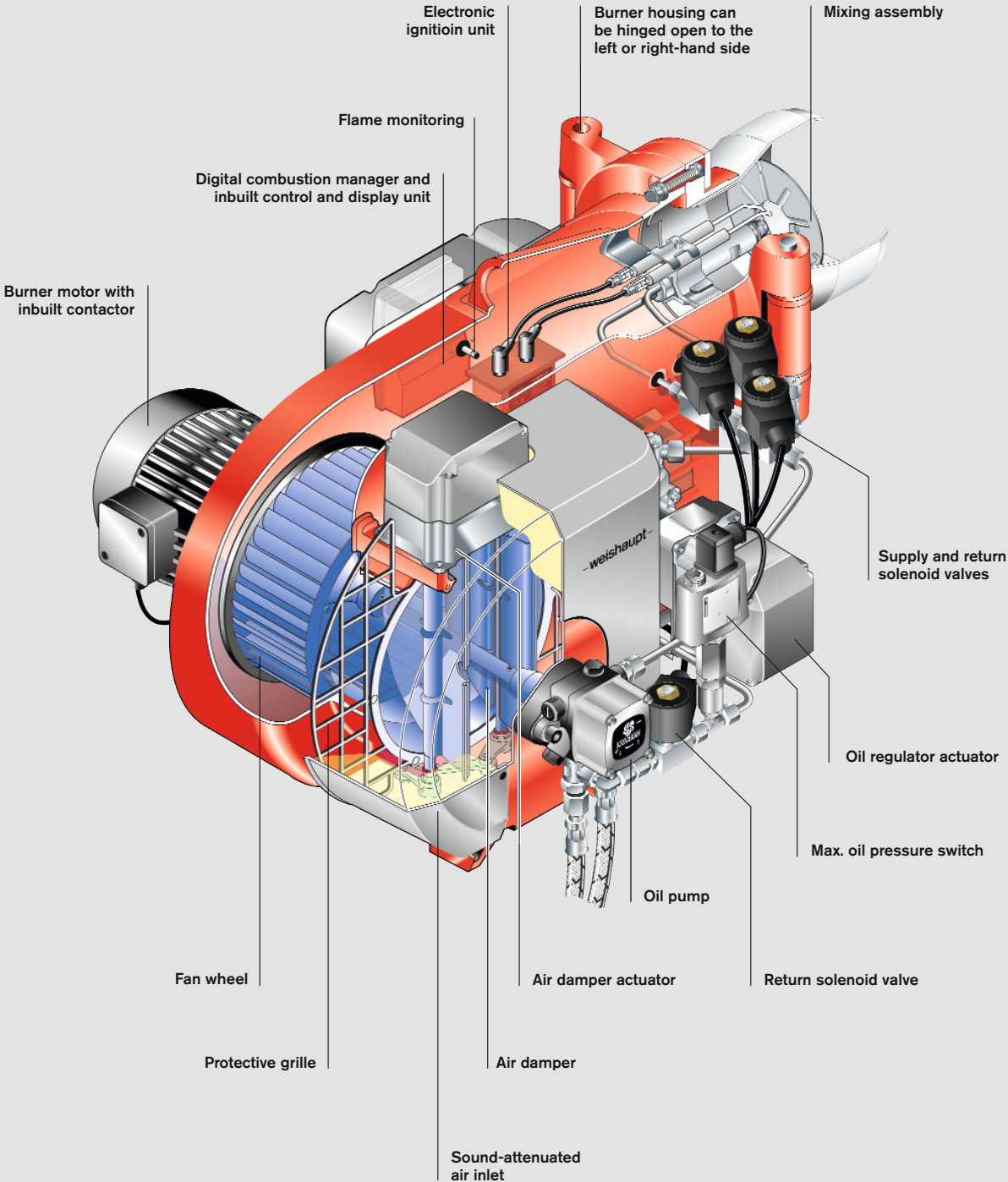

WM-L10 version R

Burner selection WM-L10, versions T and R

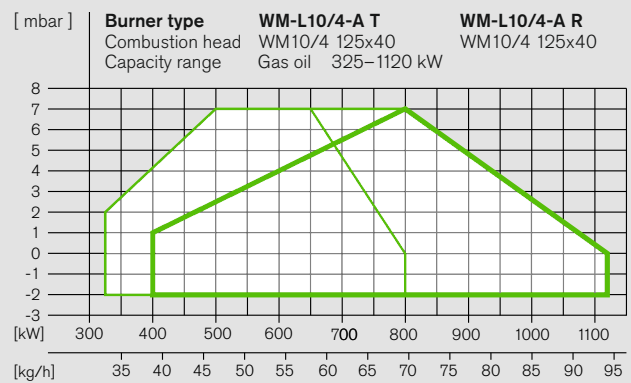
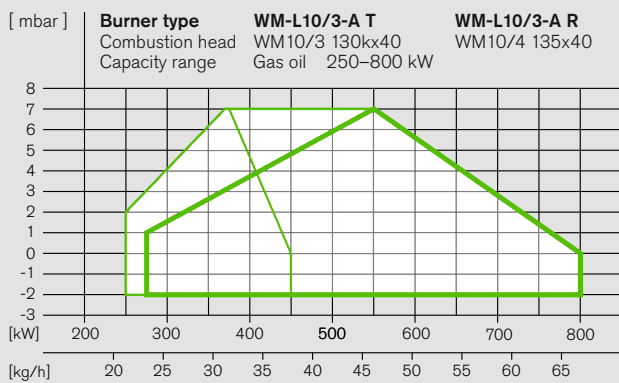
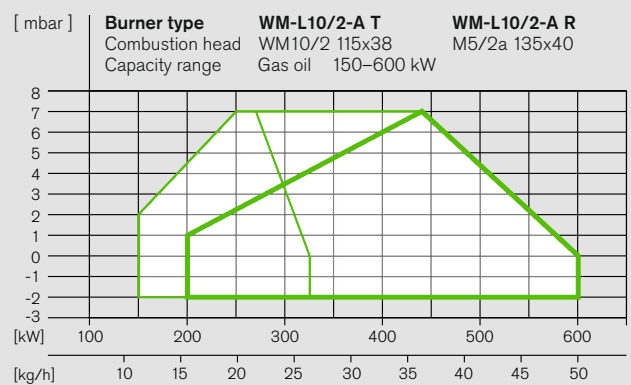
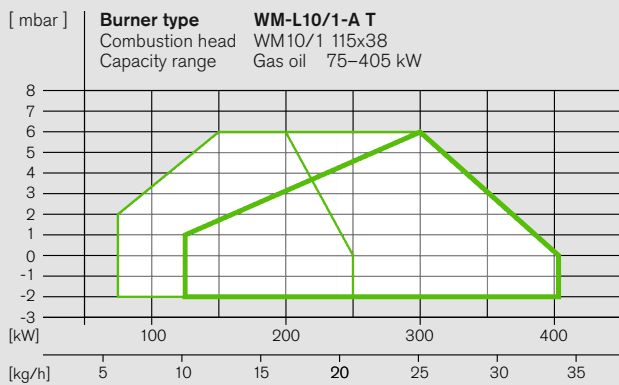

Gas oil: Capacity with combustion head

- Closed —
- Open —

Please refer to page 15 for notes on the capacity graphs.

Burner selection / gas valve train sizing

WM-G10, version ZM

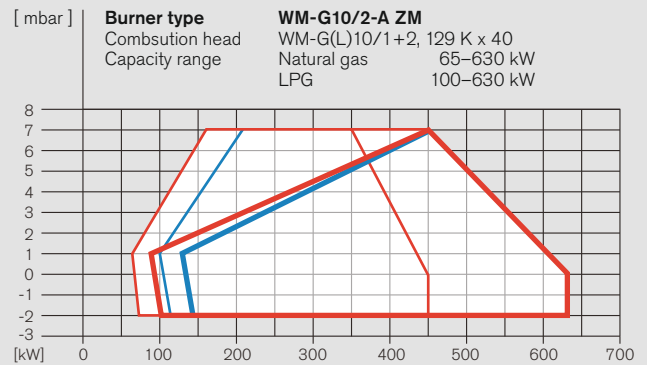
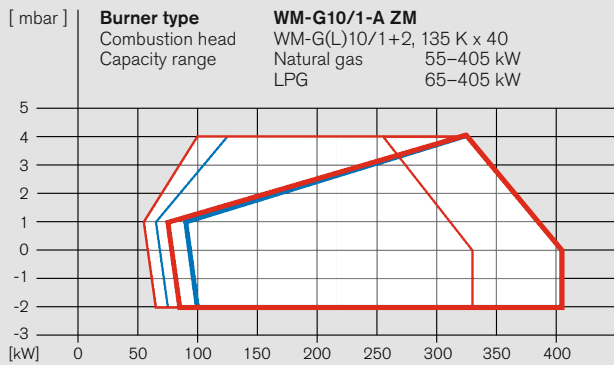

WM-G10/1-A, version ZM

Burner rating kW	Low-pressure supply (with FRS regulator) Flow pressure into shutoff valve	High-pressure supply (with HP regulator) F. p. into double valve assembly
	Nominal valve train diameter	Nominal valve train diameter
	3/4" 1" 1 1/2" 2"	3/4" 1" 1 1/2" 2"
	Nominal diameter of gas butterfly	Nominal diameter of gas butterfly
	40 40 40 40	40 40 40 40

Natural gas E	LHV = 10.35 kWh/m³; d = 0.606; W _i = 13.295 kWh/m³			
150	12	-	-	5
175	14	9	-	6
200	16	10	-	6
225	19	11	-	7
250	22	12	-	8
275	26	14	8	10
300	31	16	9	11
350	41	20	12	15
405	53	25	14	20

Natural gas LL	LHV = 8.83 kWh/m³; d = 0.641; W _i = 11.029 kWh/m³			
150	15	10	-	7
175	18	11	8	8
200	22	12	9	9
225	26	14	9	10
250	31	16	10	12
275	37	18	11	13
300	43	21	12	16
350	57	27	15	21
405	75	35	19	28

LPG	LHV = 25.89 kWh/m³; d = 1.555; W _i = 20.762 kWh/m³			
150	8	-	-	4
175	9	-	-	4
200	10	-	-	4
225	11	-	-	5
250	12	8	-	5
275	14	9	-	6
300	16	10	-	7
350	21	12	9	9
405	27	15	11	12

WM-G10/2-A, version ZM

Burner rating kW	Low-pressure supply (with FRS regulator) Flow pressure into shutoff valve	High-pressure supply (with HP regulator) F. p. into double valve assembly
	Nominal valve train diameter	Nominal valve train diameter
	3/4" 1" 1 1/2" 2" 65	3/4" 1" 1 1/2" 2" 65
	Nominal diameter of gas butterfly	Nominal diameter of gas butterfly
	40 40 40 40 40	40 40 40 40 40

Natural gas E	LHV = 10.35 kWh/m³; d = 0.606; W _i = 13.295 kWh/m³				
300	29	14	8	-	10
350	39	19	11	-	14
400	51	24	13	9	18
450	63	29	16	11	23
500	77	35	18	12	28
550	92	41	21	14	33
600	109	48	24	15	39
630	119	53	26	16	43

Natural gas LL	LHV = 8.83 kWh/m³; d = 0.641; W _i = 11.029 kWh/m³				
300	42	20	11	-	15
350	56	26	14	10	20
400	72	33	17	12	26
450	90	41	21	14	33
500	110	49	24	16	40
550	132	58	28	18	47
600	155	68	32	20	55
630	171	74	35	21	60

LPG	LHV = 25.89 kWh/m³; d = 1.555; W _i = 20.762 kWh/m³				
300	15	9	-	-	6
350	20	11	-	-	8
400	25	14	10	8	10
450	31	17	11	9	13
500	37	20	13	10	15
550	44	23	14	12	18
600	51	26	16	13	21
630	55	28	17	13	23

Nat. gas: Capacity with comb. head **LPG: Capacity with comb. head**
 Closed — Closed —
 Open — Open —

Please refer to page 15 for notes on the gas supply.

The LHV is referenced to 0 °C and 1013 mbar atmospheric. All pressures are in mbar.

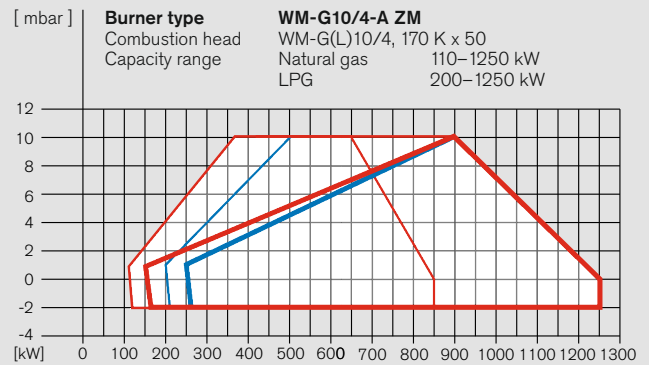
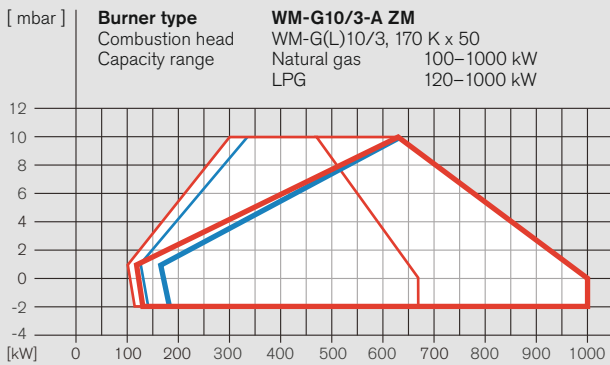

WM-G10/3-A, version ZM

Burner rating kW	Low-pressure supply (with FRS regulator)						High-pressure supply (with HP regulator)					
	Flow pressure into shutoff valve						F. p. into double valve assembly					
	Nominal valve train diameter						Nominal valve train diameter					
	3/4"	1"	1 1/2"	2"	65	80 100	3/4"	1"	1 1/2"	2"	65	80 100
	Nominal diameter of gas butterfly						Nominal diameter of gas butterfly					
	50	50	50	50	50	50	50	50	50	50	50	50

Natural gas E	LHV = 10.35 kWh/m ³ ; d = 0.606; W _i = 13.295 kWh/m ³											
500	73	31	14	8	–	–	24	10	8	4	–	–
550	88	37	17	10	–	–	29	12	9	5	–	–
600	104	44	19	11	9	–	34	14	11	6	5	–
650	121	51	22	12	10	9	40	16	12	7	6	5
700	140	58	25	13	10	9	46	19	14	8	7	6
750	160	66	28	15	11	10	53	21	16	9	7	7
800	182	75	32	16	12	11	60	24	18	10	8	7
850	205	84	35	18	13	12	67	26	20	11	9	8
900	229	93	39	19	14	13	75	29	22	12	10	9
950	255	103	42	21	16	13	84	32	25	13	11	10
1000	282	114	46	23	17	14	92	36	27	14	11	10

Natural gas LL	LHV = 8.83 kWh/m ³ ; d = 0.641; W _i = 11.029 kWh/m ³											
500	105	44	19	11	8	–	34	14	11	6	5	–
550	126	52	23	12	10	9	41	17	13	7	6	6
600	149	62	26	14	11	10	49	20	15	8	7	6
650	175	72	30	16	12	11	58	23	17	9	8	7
700	202	82	35	18	13	12	67	26	20	11	9	8
750	231	94	39	20	15	13	76	30	23	12	10	9
800	262	106	44	22	16	14	86	34	25	13	11	10
850	296	119	49	24	17	15	97	37	28	15	12	11
900	–	133	54	26	19	16	108	42	31	16	13	12
950	–	148	60	28	20	17	120	46	35	18	14	13
1000	–	163	65	31	22	18	133	51	38	19	15	14

LPG	LHV = 25.89 kWh/m ³ ; d = 1.555; W _i = 20.762 kWh/m ³											
500	33	16	9	–	–	–	12	6	5	–	–	–
550	40	19	11	–	–	–	14	7	6	–	–	–
600	47	22	12	8	–	–	17	8	7	5	–	–
650	54	25	13	9	8	–	19	9	8	6	5	–
700	62	29	15	10	9	8	22	11	9	6	6	6
750	71	32	17	11	10	9	25	12	10	7	7	6
800	80	36	18	12	10	10	29	14	11	8	7	7
850	90	40	20	13	11	11	32	15	13	9	8	8
900	100	44	22	14	12	11	35	17	14	9	9	8
950	111	49	24	15	13	12	39	18	15	10	9	9
1000	122	53	26	16	14	13	43	20	16	11	10	10

WM-G10/4-A, version ZM

Burner rating kW	Low-pressure supply (with FRS regulator)						High-pressure supply (with HP regulator)					
	Flow pressure into shutoff valve						F. p. into double valve assembly					
	Nominal valve train diameter						Nominal valve train diameter					
	1"	1 1/2"	2"	65	80 100		1"	1 1/2"	2"	65	80 100	
	Nominal diameter of gas butterfly						Nominal diameter of gas butterfly					
	50	50	50	50	50	50	50	50	50	40	50	

Natural gas E	LHV = 10.35 kWh/m ³ ; d = 0.606; W _i = 13.295 kWh/m ³											
600	45	20	12	10	9	8	15	12	7	6	6	6
700	60	27	15	12	11	11	20	16	10	9	8	8
800	77	34	19	15	14	13	26	21	13	11	10	10
900	95	41	21	17	15	14	31	24	14	12	11	11
1000	115	48	24	18	15	14	37	28	15	13	12	11
1100	137	55	26	19	16	15	43	32	17	13	12	12
1200	160	64	29	21	17	15	49	37	18	14	13	12
1250	173	68	31	21	18	16	52	39	19	15	13	12

Natural gas LL	LHV = 8.83 kWh/m ³ ; d = 0.641; W _i = 11.029 kWh/m ³											
600	62	27	15	12	10	10	20	16	9	8	7	7
700	84	36	19	15	13	12	28	22	12	10	10	9
800	109	46	24	18	16	15	36	28	16	13	13	12
900	135	56	28	21	18	16	43	33	18	15	14	13
1000	164	66	31	23	19	17	51	39	20	16	15	14
1100	195	77	35	25	21	18	60	45	22	17	16	15
1200	230	90	40	27	22	19	69	51	24	19	17	16
1250	249	96	42	28	23	20	74	55	25	19	18	16

LPG	LHV = 25.89 kWh/m ³ ; d = 1.555; W _i = 20.762 kWh/m ³											
600	22	12	8	–	–	–	8	7	5	–	–	–
700	28	14	10	8	–	–	10	8	6	5	–	–
800	35	17	11	9	9	8	13	10	7	6	6	6
900	42	20	12	10	9	9	15	12	8	7	7	6
1000	51	23	13	11	10	9	17	14	8	7	7	7
1100	60	26	14	11	10	10	20	15	9	8	7	7
1200	69	30	16	12	11	10	22	17	9	8	7	7
1250	75	32	16	12	11	10	24	18	10	8	8	7

Please refer to page 15 for notes on the gas supply.

The LHV is referenced to 0 °C and 1013 mbar atmospheric. All pressures are in mbar.

Burner selection / gas valve train sizing

WM-G10, version ZM-LN

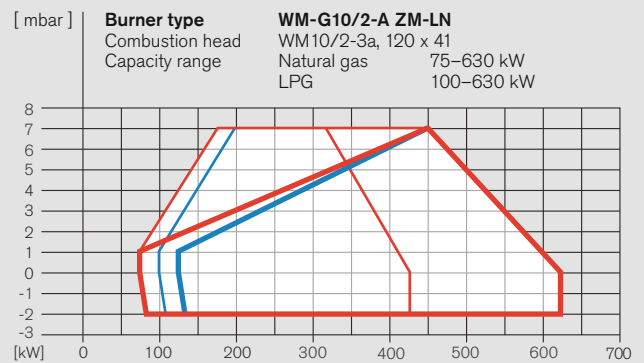
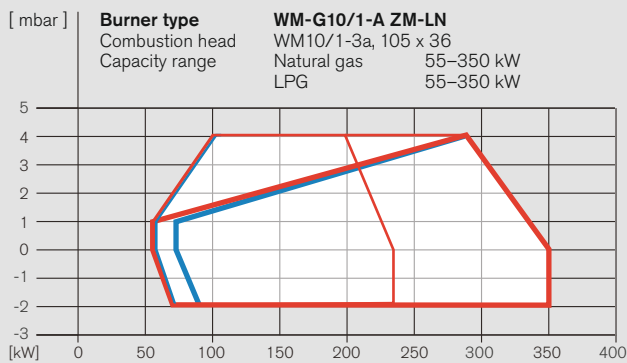

WM-G10/1-A, version ZM-LN

Burner rating kW	Low-pressure supply (with FRS regulator)	High-pressure supply (with HP regulator)
	Flow pressure into shutoff valve Nominal valve train diameter 3/4" 1" 1 1/2" 2"	F. p. into double valve assembly Nominal valve train diameter 3/4" 1" 1 1/2" 2"
	Nominal diameter of gas butterfly 25 25 25 25	Nominal diameter of gas butterfly 25 25 25 25

Natural gas E	LHV = 10.35 kWh/m ³ ; d = 0.606; W _i = 13.295 kWh/m ³
150	12 9 - -
175	16 11 9 -
200	19 13 10 9
225	23 14 11 10
250	27 16 12 10
275	31 18 13 11
300	35 20 14 12
325	40 22 15 13
350	45 25 16 14

Natural gas LL	LHV = 8.83 kWh/m ³ ; d = 0.641; W _i = 11.029 kWh/m ³
150	16 11 8 -
175	20 13 10 9
200	25 15 12 10
225	30 18 13 11
250	35 20 14 12
275	41 23 16 13
300	48 26 17 14
325	55 29 19 15
350	62 32 20 16

LPG	LHV = 25.89 kWh/m ³ ; d = 1.555; W _i = 20.762 kWh/m ³
150	8 - - -
175	10 - - -
200	12 9 8 -
225	14 11 9 9
250	16 12 10 9
275	18 13 11 10
300	20 14 11 10
325	22 15 12 11
350	24 16 13 11

WM-G10/2-A, version ZM-LN

Burner rating kW	Low-pressure supply (with FRS regulator)	High-pressure supply (with HP regulator)
	Flow pressure into shutoff valve Nominal valve train diameter 3/4" 1" 1 1/2" 2" 65	F. p. into double valve assembly Nominal valve train diameter 3/4" 1" 1 1/2" 2" 65
	Nominal diameter of gas butterfly 40 40 40 40 40	Nominal diameter of gas butterfly 40 40 40 40 40

Natural gas E	LHV = 10.35 kWh/m ³ ; d = 0.606; W _i = 13.295 kWh/m ³
300	32 17 10 8 -
350	42 21 13 10 9
400	54 27 16 12 11
450	66 32 18 14 12
500	80 38 21 15 13
550	95 44 23 16 14
600	111 50 26 18 15
630	121 55 28 19 16

Natural gas LL	LHV = 8.83 kWh/m ³ ; d = 0.641; W _i = 11.029 kWh/m ³
300	44 22 13 10 9
350	58 28 16 12 11
400	75 36 20 14 13
450	92 43 23 16 14
500	112 51 27 18 16
550	134 60 30 20 17
600	157 69 34 22 19
630	172 76 37 23 20

LPG	LHV = 25.89 kWh/m ³ ; d = 1.555; W _i = 20.762 kWh/m ³
300	16 10 - - -
350	21 12 9 - -
400	27 16 11 10 9
450	31 17 12 10 9
500	37 19 13 10 9
550	42 22 13 10 10
600	49 24 14 11 10
630	53 26 15 11 10

Nat. gas: Capacity with comb. head **LPG: Capacity with comb. head**
 Closed — Closed —
 Open — Open —

Please refer to page 15 for notes on the gas supply.

The LHV is referenced to 0 °C and 1013 mbar atmospheric. All pressures are in mbar.

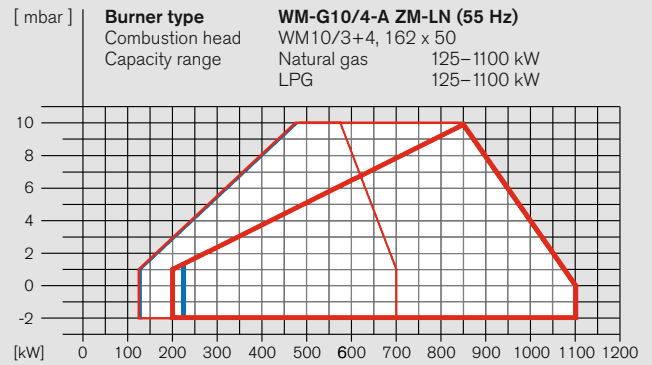
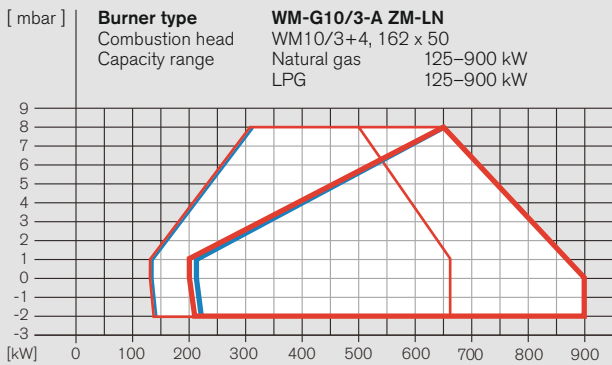

WM-G10/3-A, version ZM-LN

Burner rating kW	Low-pressure supply (with FRS regulator)						High-pressure supply (with HP regulator)					
	Flow pressure into shutoff valve						F. p. into double valve assembly					
	Nominal valve train diameter						Nominal valve train diameter					
	3/4"	1"	1 1/2"	2"	65	80 100	3/4"	1"	1 1/2"	2"	65	80 100
	Nominal diameter of gas butterfly						Nominal diameter of gas butterfly					
	50	50	50	50	50	50	50	50	50	50	50	50

Natural gas E	LHV = 10.35 kWh/m ³ ; d = 0.606; W _i = 13.295 kWh/m ³												
450	63	29	16	11	10	9	9	23	11	10	7	6	6
500	77	35	19	13	11	11	10	28	14	12	9	8	8
550	93	42	22	15	13	12	12	34	17	14	10	10	9
600	110	50	25	17	15	14	13	40	20	17	12	11	11
650	128	57	29	19	16	15	15	47	23	19	14	12	12
700	147	65	32	20	17	16	15	53	25	21	15	13	13
750	167	73	35	21	18	17	16	60	28	23	16	14	13
800	189	81	38	23	19	18	17	67	30	25	17	15	14
850	212	90	42	25	20	18	18	74	33	27	18	16	15
900	236	100	45	26	21	19	18	82	36	29	19	17	16

Natural gas LL	LHV = 8.83 kWh/m ³ ; d = 0.641; W _i = 11.029 kWh/m ³												
450	89	39	20	12	11	10	10	31	15	12	8	7	7
500	109	48	23	15	13	12	11	39	18	15	10	9	9
550	131	57	28	17	15	14	13	46	21	18	12	11	10
600	155	67	32	20	16	15	15	55	25	21	14	13	12
650	181	78	37	22	18	17	16	64	29	24	16	14	13
700	208	89	41	24	20	18	17	73	32	26	17	15	14
750	238	100	45	26	21	19	18	82	36	29	18	16	15
800	269	113	50	28	22	20	19	93	40	32	20	17	16
850	-	126	55	30	24	21	20	103	44	35	21	18	17
900	-	140	60	32	25	22	21	115	48	38	23	19	18

LPG	LHV = 25.89 kWh/m ³ ; d = 1.555; W _i = 20.762 kWh/m ³												
450	30	16	10	8	-	-	-	12	7	6	5	-	-
500	36	19	12	10	9	9	9	15	9	8	7	6	6
550	43	23	14	11	11	10	10	18	11	10	8	8	7
600	51	26	16	13	12	12	11	21	13	11	10	9	9
650	59	30	19	15	14	13	13	25	15	13	11	11	10
700	68	34	21	16	15	14	14	28	16	15	12	12	11
750	76	37	22	16	15	14	14	31	17	15	12	12	12
800	85	41	23	17	15	15	15	34	19	16	13	12	12
850	94	45	25	18	16	15	15	37	20	17	13	13	12
900	104	49	26	18	16	16	15	40	21	18	14	13	13

WM-G10/4-A, version ZM-LN

Burner rating kW	Low-pressure supply (with FRS regulator)						High-pressure supply (with HP regulator)					
	Flow pressure into shutoff valve						F. p. into double valve assembly					
	Nominal valve train diameter						Nominal valve train diameter					
	3/4"	1"	1 1/2"	2"	65	80 100	3/4"	1"	1 1/2"	2"	65	80 100
	Nominal diameter of gas butterfly						Nominal diameter of gas butterfly					
	50	50	50	50	50	50	50	50	50	50	50	50

Natural gas E	LHV = 10.35 kWh/m ³ ; d = 0.606; W _i = 13.295 kWh/m ³												
650	131	60	32	22	19	18	18	50	26	22	17	16	15
700	150	68	35	23	20	19	18	56	28	24	18	16	16
750	170	76	38	25	21	20	19	63	31	26	19	17	16
800	192	84	41	26	22	21	20	70	34	28	20	18	17
850	215	94	45	28	23	22	21	77	36	30	21	19	18
900	239	103	49	29	25	23	22	85	39	32	22	20	19
950	265	113	53	31	26	24	22	94	43	35	23	21	20
1000	292	124	57	33	27	25	23	103	46	37	24	22	21
1050	-	135	61	35	28	26	24	112	49	40	26	23	22
1100	-	147	66	37	29	27	25	122	53	42	27	24	22

Natural gas LL	LHV = 8.83 kWh/m ³ ; d = 0.641; W _i = 11.029 kWh/m ³												
650	185	82	41	26	22	21	20	68	33	28	20	18	18
700	212	93	45	28	24	22	21	77	36	30	21	19	18
750	242	104	50	30	25	23	22	87	40	33	23	20	19
800	273	117	54	32	27	24	23	97	44	36	24	21	20
850	-	130	59	34	28	26	24	108	48	39	25	23	22
900	-	144	65	37	30	27	25	119	52	42	27	24	23
950	-	159	70	39	31	28	26	131	57	45	29	25	24
1000	-	174	76	42	33	29	27	-	61	49	30	26	25
1050	-	190	82	44	34	31	29	-	66	52	32	27	26
1100	-	207	89	47	36	32	30	-	71	56	33	29	27

LPG	LHV = 25.89 kWh/m ³ ; d = 1.555; W _i = 20.762 kWh/m ³												
650	62	33	21	17	16	16	16	27	17	16	14	13	13
700	70	36	23	18	17	16	16	30	18	17	14	14	13
750	78	40	24	19	17	17	16	33	20	18	15	14	14
800	87	43	26	19	18	17	17	36	21	19	15	15	14
850	97	47	27	20	18	18	17	39	22	20	16	15	15
900	107	51	29	21	19	18	18	42	23	21	16	15	15
950	117	55	30	22	19	19	18	46	25	22	17	16	16
1000	129	60	32	23	20	19	19	50	26	23	17	16	16
1050	140	65	34	23	21	20	19	53	28	24	18	17	17
1100	153	69	36	24	21	20	19	58	29	25	19	17	17

Please refer to page 15 for notes on the gas supply.

The LHV is referenced to 0 °C and 1013 mbar atmospheric. All pressures are in mbar.

Burner selection / gas valve train sizing

WM-GL10, versions ZM-T and ZM-R

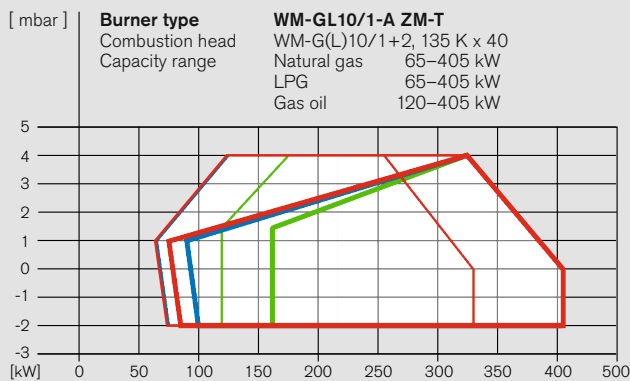

WM-GL10/1-A, version ZM-T

Burner rating kW	Low-pressure supply (with FRS regulator)	High-pressure supply (with HP regulator)
	Flow pressure into shutoff valve	F. p. into double valve assembly
	Nominal valve train diameter	Nominal valve train diameter
	¾" 1" 1½" 2"	¾" 1" 1½" 2"
	Nominal diameter of gas butterfly	Nominal diameter of gas butterfly
	40 40 40 40	40 40 40 40

Natural gas E	LHV = 10.35 kWh/m ³ ; d = 0.606; W _i = 13.295 kWh/m ³			
150	12	-	-	5
175	14	9	-	6
200	16	10	-	6
225	19	11	-	7
250	22	12	-	8
275	26	14	8	10
300	31	16	9	11
350	41	20	12	15
405	53	25	14	20

Natural gas LL	LHV = 8.83 kWh/m ³ ; d = 0.641; W _i = 11.029 kWh/m ³			
150	15	10	-	7
175	18	11	8	8
200	22	12	9	9
225	26	14	9	10
250	31	16	10	12
275	37	18	11	13
300	43	21	12	16
350	57	27	15	21
405	75	35	19	28

LPG	LHV = 25.89 kWh/m ³ ; d = 1.555; W _i = 20.762 kWh/m ³			
150	8	-	-	4
175	9	-	-	4
200	10	-	-	4
225	11	-	-	5
250	12	8	-	5
275	14	9	-	6
300	16	10	-	7
350	21	12	9	9
405	27	15	11	12

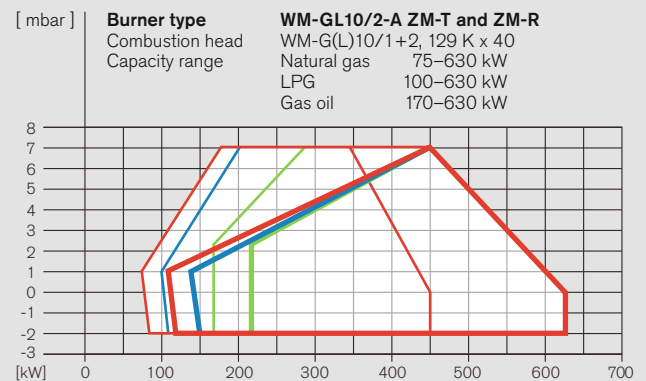

WM-GL10/2-A, versions ZM-T and ZM-R

Burner rating kW	Low-pressure supply (with FRS regulator)	High-pressure supply (with HP regulator)
	Flow pressure into shutoff valve	F. p. into double valve assembly
	Nominal valve train diameter	Nominal valve train diameter
	¾" 1" 1½" 2" 65	¾" 1" 1½" 2" 65
	Nominal diameter of gas butterfly	Nominal diameter of gas butterfly
	40 40 40 40 40	40 40 40 40 40

Natural gas E	LHV = 10.35 kWh/m ³ ; d = 0.606; W _i = 13.295 kWh/m ³				
300	29	14	8	-	10
350	39	19	11	-	14
400	51	24	13	9	18
450	63	29	16	11	23
500	77	35	18	12	28
550	92	41	21	14	33
600	109	48	24	15	39
630	119	53	26	16	43

Natural gas LL	LHV = 8.83 kWh/m ³ ; d = 0.641; W _i = 11.029 kWh/m ³				
300	42	20	11	-	15
350	56	26	14	10	20
400	72	33	17	12	26
450	90	41	21	14	33
500	110	49	24	16	40
550	132	58	28	18	47
600	155	68	32	20	55
630	171	74	35	21	60

LPG	LHV = 25.89 kWh/m ³ ; d = 1.555; W _i = 20.762 kWh/m ³				
300	15	9	-	-	6
350	20	11	-	-	8
400	25	14	10	8	10
450	31	17	11	9	13
500	37	20	13	10	15
550	44	23	14	12	18
600	51	26	16	13	21
630	55	28	17	13	23

Nat. gas: Capacity with comb. head
Closed —
Open —

LPG: Capacity with comb. head
Closed —
Open —

Gas oil: Capacity with comb. head
Closed —
Open —

Please refer to page 15 for notes on the gas supply.

The LHV is referenced to 0 °C and 1013 mbar atmospheric. All pressures are in mbar.

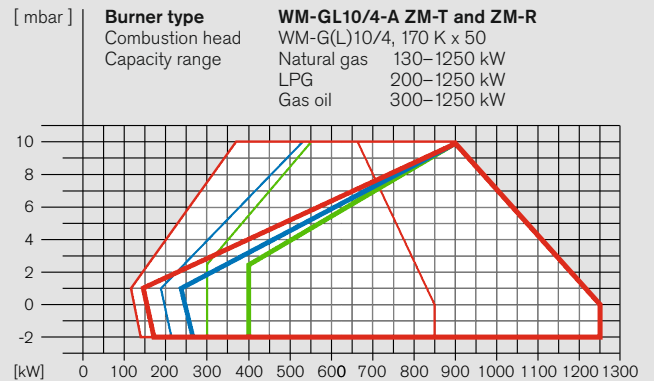
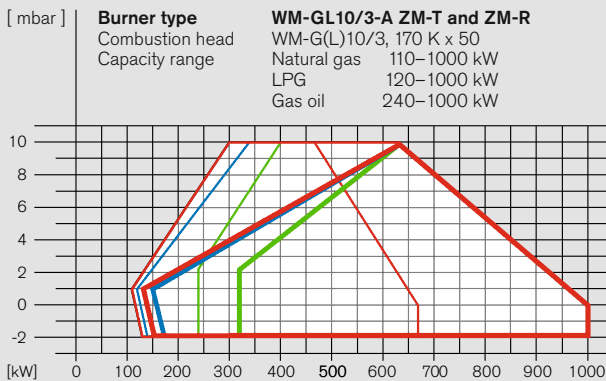

WM-GL10/3-A, versions ZM-T and ZM-R

Burner rating kW	Low-pressure supply (with FRS regulator)						High-pressure supply (with HP regulator)					
	Flow pressure into shutoff valve						F. p. into double valve assembly					
	Nominal valve train diameter						Nominal valve train diameter					
	3/4"	1"	1 1/2"	2"	65	80 100	3/4"	1"	1 1/2"	2"	65	80 100
	Nominal diameter of gas butterfly						Nominal diameter of gas butterfly					
	50	50	50	50	50	50	50	50	50	50	50	50 50

Natural gas E LHV = 10.35 kWh/m³; d = 0.606; W_i = 13.295 kWh/m³

500	73	31	14	8	-	-	24	10	8	4	-	-
550	88	37	17	10	-	-	29	12	9	5	-	-
600	104	44	19	11	9	-	34	14	11	6	5	-
650	121	51	22	12	10	9	40	16	12	7	6	5
700	140	58	25	13	10	9	46	19	14	8	7	6
750	160	66	28	15	11	10	53	21	16	9	7	7
800	182	75	32	16	12	11	60	24	18	10	8	7
850	205	84	35	18	13	12	67	26	20	11	9	8
900	229	93	39	19	14	13	75	29	22	12	10	9
950	255	103	42	21	16	13	84	32	25	13	11	10
1000	282	114	46	23	17	14	92	36	27	14	11	10

Natural gas LL LHV = 8.83 kWh/m³; d = 0.641; W_i = 11.029 kWh/m³

500	105	44	19	11	8	-	34	14	11	6	5	-
550	126	52	23	12	10	9	41	17	13	7	6	6
600	149	62	26	14	11	10	49	20	15	8	7	6
650	175	72	30	16	12	11	58	23	17	9	8	7
700	202	82	35	18	13	12	67	26	20	11	9	8
750	231	94	39	20	15	13	76	30	23	12	10	9
800	262	106	44	22	16	14	86	34	25	13	11	10
850	296	119	49	24	17	15	97	37	28	15	12	11
900	-	133	54	26	19	16	108	42	31	16	13	12
950	-	148	60	28	20	17	120	46	35	18	14	13
1000	-	163	65	31	22	18	133	51	38	19	15	14

LPG LHV = 25.89 kWh/m³; d = 1.555; W_i = 20.762 kWh/m³

500	33	16	9	-	-	-	12	6	5	-	-	-
550	40	19	11	-	-	-	14	7	6	-	-	-
600	47	22	12	8	-	-	17	8	7	5	-	-
650	54	25	13	9	8	-	19	9	8	6	5	-
700	62	29	15	10	9	8	22	11	9	6	6	6
750	71	32	17	11	10	9	25	12	10	7	7	6
800	80	36	18	12	10	10	29	14	11	8	7	7
850	90	40	20	13	11	11	32	15	13	9	8	8
900	100	44	22	14	12	11	35	17	14	9	9	8
950	111	49	24	15	13	12	39	18	15	10	9	9
1000	122	53	26	16	14	13	43	20	16	11	10	10

WM-GL10/4-A, versions ZM-T and ZM-R

Burner rating kW	Low-pressure supply (with FRS regulator)						High-pressure supply (with HP regulator)					
	Flow pressure into shutoff valve						F. p. into double valve assembly					
	Nominal valve train diameter						Nominal valve train diameter					
	1"	1 1/2"	2"	65	80 100		1"	1 1/2"	2"	65	80 100	
	Nominal diameter of gas butterfly						Nominal diameter of gas butterfly					
	50	50	50	50	50	50	50	50	50	40	50	

Natural gas E LHV = 10.35 kWh/m³; d = 0.606; W_i = 13.295 kWh/m³

600	45	20	12	10	9	8	15	12	7	6	6	6
700	60	27	15	12	11	11	20	16	10	9	8	8
800	77	34	19	15	14	13	26	21	13	11	10	10
900	95	41	21	17	15	14	31	24	14	12	11	11
1000	115	48	24	18	15	14	37	28	15	13	12	11
1100	137	55	26	19	16	15	43	32	17	13	12	12
1200	160	64	29	21	17	15	49	37	18	14	13	12
1250	173	68	31	21	18	16	52	39	19	15	13	12

Natural gas LL LHV = 8.83 kWh/m³; d = 0.641; W_i = 11.029 kWh/m³

600	62	27	15	12	10	10	20	16	9	8	7	7
700	84	36	19	15	13	12	28	22	12	10	10	9
800	109	46	24	18	16	15	36	28	16	13	13	12
900	135	56	28	21	18	16	43	33	18	15	14	13
1000	164	66	31	23	19	17	51	39	20	16	15	14
1100	195	77	35	25	21	18	60	45	22	17	16	15
1200	230	90	40	27	22	19	69	51	24	19	17	16
1250	249	96	42	28	23	20	74	55	25	19	18	16

LPG LHV = 25.89 kWh/m³; d = 1.555; W_i = 20.762 kWh/m³

600	22	12	8	-	-	-	8	7	5	-	-	-
700	28	14	10	8	-	-	10	8	6	5	-	-
800	35	17	11	9	9	8	13	10	7	6	6	6
900	42	20	12	10	9	9	15	12	8	7	7	6
1000	51	23	13	11	10	9	17	14	8	7	7	7
1100	60	26	14	11	10	10	20	15	9	8	7	7
1200	69	30	16	12	11	10	22	17	9	8	7	7
1250	75	32	16	12	11	10	24	18	10	8	8	7

Please refer to page 15 for notes on the gas supply.

The LHV is referenced to 0 °C and 1013 mbar atmospheric. All pressures are in mbar.

Scope of delivery

Description	WM-L10 T	WM-L10 R	WM-G10 ZM WM-G10 ZM-LN	WM-GL10 ZM-T	WM-GL10 ZM-R
Burner housing, hinged flange, housing cover, Weishaupt burner motor, air inlet housing, fan wheel, combustion head, ignition unit, ignition cable, ignition electrodes, combustion manager with control unit, flame sensor, actuators, flange gasket, limit switch on hinged flange, fixing screws	●	●	●	●	●
Digital combustion manager W-FM50	●	●	●	-	-
W-FM54	-	-	-	●	●
W-FM100	○	○	○	○	○
W-FM200	○	○	○	○	○
Valve proving via pressure switch and W-FM	-	-	●	●	●
Class-A double gas valve assembly	-	-	●	●	●
Gas butterfly valve	-	-	●	●	●
Air pressure switch	○	○	●	●	●
Low gas pressure switch	-	-	●	●	●
Preset, capacity-based mixing assembly	●	●	●	●	●
Actuators for compound regulation of fuel and air via W-FM:					
Air damper actuator	●	●	●	●	●
Gas butterfly valve actuator	-	-	●	●	●
Oil regulator actuator	-	●	-	-	●
Oil pressure switch in return	-	●	-	-	●
Oil pump fitted to burner	●	●	-	●	●
Oil hoses	●	●	-	●	●
4 oil solenoid valves, oil regulator, nozzle head with pre-installed regulating nozzle	-	●	-	-	●
3 oil solenoid valves, three-stage nozzle head with pre-installed oil nozzles	●			●	
1 additional safety solenoid valve	○	-	-	●	-
Electromagnetic clutch	○	○	-	○	●
DOL motor contactor fitted to motor ¹⁾	●	●	● ²⁾	●	●
IP 54 protection	●	●	●	●	●

EN 676 stipulates that ball valves, gas filters, and gas pressure regulators form part of the burner supply (see Weishaupt accessories list).

Gas valve train handing should be confirmed at the time of order.

If not otherwise specified, the burner will be supplied configured for a right-handed gas valve train.

The burner can be altered for the opposite gas valve train handing through rotation of the gas butterfly valve and actuator.

Please enquire or see the special equipment section of this brochure for further burner executions.

● Standard

○ Optional

¹⁾ The necessary motor protection can be provided either by a motor protection switch (supplied and fitted into a panel by others), or with integral motor overload protection (see special equipment).

²⁾ The WM-G10/4-A ZM-LN is equipped with VSD as standard (55 Hz motor)

Order numbers

Oil burners, version T

Burner type	Version	Order No.
WM-L10/1-A	T	211 110 10
WM-L10/2-A	T	211 110 20
WM-L10/3-A	T	211 110 30
WM-L10/4-A	T	211 110 40

DIN CERTCO: 5G1010

Gas burners, version ZM-LN

Burner type	Version	Gas valve assembly size	Order No.
WM-G10/1-A	ZM	R ¾	217 111 10
		R 1	217 111 11
		R 1½	217 111 12
		R 2	217 111 13
WM-G10/2-A	ZM	R ¾	217 114 10
		R 1	217 114 11
		R 1½	217 114 12
		R 2	217 114 13
WM-G10/3-A	ZM	DN 65	217 114 14
		R ¾	217 117 10
		R 1	217 117 11
		R 1½	217 117 12
		R 2	217 117 13
WM-G10/4-A	ZM	DN 65	217 117 14
		DN 80	217 117 15
		DN 100	217 117 16
		R 1	217 120 11
		R 1½	217 120 12
WM-G10/4-A	ZM	R 2	217 120 13
		DN 65	217 120 14
		DN 80	217 120 15
		DN 100	217 120 16

CE-PIN: CE 0085BQ0027

Oil burners, version R

Burner type	Version	Order No.
WM-L10/2-A	R	215 110 20
WM-L10/3-A	R	215 110 30
WM-L10/4-A	R	215 110 40

DIN CERTCO: 5G1010

Gas burners, version ZM

Burner type	Version	Gas valve assembly size	Order No.
WM-G10/1-A	ZM-LN	R ¾	217 112 10
		R 1	217 112 11
		R 1½	217 112 12
		R 2	217 112 13
WM-G10/2-A	ZM-LN	R ¾	217 115 10
		R 1	217 115 11
		R 1½	217 115 12
		R 2	217 115 13
WM-G10/3-A	ZM-LN	DN 65	217 115 14
		R ¾	217 118 10
		R 1	217 118 11
		R 1½	217 118 12
		R 2	217 118 13
WM-G10/4-A	ZM-LN	DN 65	217 118 14
		DN 80	217 118 15
		DN 100	217 118 16
		R ¾	217 127 10
		R 1	217 127 11
WM-G10/4-A	ZM-LN	R 1½	217 127 12
		R 2	217 127 13
		DN 65	217 127 14
		DN 80	217 127 15
WM-G10/4-A	ZM-LN	DN 100	217 127 16
		Available 2018-Q4	

CE-PIN: CE 0085BQ0027

Order numbers

Dual-fuel burners, version ZM-T

Burner type	Version	Gas valve assembly size	Order No.
WM-GL10/1-A	ZM-T	R ¾	218 111 10
		R 1	218 111 11
		R 1½	218 111 12
		R 2	218 111 13
WM-GL10/2-A	ZM-T	R ¾	218 112 10
		R 1	218 112 11
		R 1½	218 112 12
		R 2	218 112 13
WM-GL10/3-A	ZM-T	DN 65	218 112 14
		R ¾	218 113 10
		R 1	218 113 11
		R 1½	218 113 12
		R 2	218 113 13
		DN 65	218 113 14
WM-GL10/4-A	ZM-T	DN 80	218 113 15
		DN 100	218 113 16
		R 1	218 114 11
		R 1½	218 114 12
		R 2	218 114 13
		DN 65	218 114 14
		DN 80	218 114 15
		DN 100	218 114 16

CE-PIN: CE 0085BR0136
DIN CERTCO: 5G1025M

Dual-fuel burners, version ZM-R

Burner type	Version	Gas valve assembly size	Order No.
WM-GL10/2-A	ZM-R	R ¾	218 115 10
		R 1	218 115 11
		R 1½	218 115 12
		R 2	218 115 13
		DN 65	218 115 14
WM-GL10/3-A	ZM-R	R ¾	218 116 10
		R 1	218 116 11
		R 1½	218 116 12
		R 2	218 116 13
		DN 65	218 116 14
		DN 80	218 116 15
		DN 100	218 116 16
WM-GL10/4-A	ZM-R	R 1	218 117 11
		R 1½	218 117 12
		R 2	218 117 13
		DN 65	218 117 14
		DN 80	218 117 15
		DN 100	218 117 16

CE-PIN: CE 0085BR0136
DIN CERTCO: 5G1025M

Special equipment WM-L10, version T

Oil burners, version T		WM-L10/1-A	WM-L10/2-A	WM-L10/3-A	WM-L10/4-A
Pressure gauge with ball valve		210 030 18	210 030 18	210 030 18	210 030 18
Vacuum gauge with ball valve		210 030 19	210 030 19	210 030 19	210 030 19
Combustion head extension	by 100 mm	210 030 16	210 030 00	210 030 02	210 030 04
	by 200 mm	210 030 17	210 030 01	210 030 03	210 030 05
Oil hoses, 1300 mm in lieu of 1000 mm		210 003 00	210 003 00	210 003 00	210 003 00
Two-stage operation with low-impact start or changeover		210 030 31	210 030 31	210 030 31	210 030 31
Air inlet flange for ducted-air connection with LGW air pressure switch (additional LGW 50 required)	for connection from rear	210 030 20	210 030 20	210 030 20	210 030 20
	for connection from above	250 034 10	250 034 10	250 034 10	250 034 10
	for connection from below	Please enquire	Please enquire	Please enquire	Please enquire
Air inlet flange for ducted-air connection with LGW air pressure switch (in conjunction with electromagnetic clutch)	for connection from rear	250 032 94	250 032 94	250 032 94	250 032 94
	for connection from above	250 033 89	250 033 89	250 033 89	250 033 89
	for connection from below	254 034 89	254 034 89	254 034 89	254 034 89
LGW 50 air pressure switch ²⁾		210 030 08	210 030 08	210 030 08	210 030 08
VZ08 oil meter with additional safety shutoff device		210 030 07	210 030 07	210 030 07	210 030 07
VZ08 oil meter with low-frequency transmitter for external wiring and additional safety shutoff device		210 030 09	210 030 09	210 030 09	210 030 09
VZ08 oil meter with high-frequency transmitter for internal wiring (W-FM 50/200)		210 031 19	210 031 19	210 031 19	210 031 19
VZ08 oil meter with high-frequency transmitter for external wiring and additional safety shutoff device		210 031 10	210 031 10	210 031 10	210 031 10
ST 18/7 and ST 18/4 plug connections (W-FM 50/100/200)		210 030 13	210 030 13	210 030 13	210 030 13
ST 18/7 plug connection (W-FM 50 with KS20)		250 031 06	250 031 06	250 031 06	250 031 06
Burner-mounted KS20 controller (W-FM 50)		250 033 15	250 033 15	250 033 15	250 033 15
W-FM 100 (suitable for continuous firing) in lieu of W-FM 50 ²⁾	burner-mounted	210 030 32	210 030 32	210 030 32	210 030 32
	supplied loose	210 030 87	210 030 87	210 030 87	210 030 87
Solenoid valve as additional safety shutoff device ²⁾		210 030 06	210 030 06	210 030 06	210 030 06
DSB 158 oil pressure switch in supply ²⁾		210 030 23	210 030 23	210 030 23	210 030 23
QRI flame sensor in lieu of QRB ²⁾		210 030 24	210 030 24	210 030 24	210 030 24
Integral load controller and analogue signal convertor for W-FM 100		110 017 18	110 017 18	110 017 18	110 017 18
W-FM 200 in lieu of W-FM 50, with integral load controller, analogue signal convertor, and VSD module with optional fuel metering		210 030 10	210 030 10	210 030 10	210 030 10
VSD with integral frequency convertor (W-FM 50/200 required)		210 030 11	210 030 11	210 030 11	210 030 11
VSD with separate frequency convertor (W-FM 200 required) (See accessories list for frequency convertor)		210 030 12	210 030 12	210 030 12	210 030 12
W-FM 200 with extended CO/FGR functionality		250 033 78	250 033 78	250 033 78	250 033 78
WM-D90 motor with 230 V contactor and overload protection ¹⁾		250 030 86	250 030 86	250 030 86	250 030 86
ABE with Chinese-character display, supplied loose (W-FM 100/200)		110 018 53	110 018 53	110 018 53	110 018 53
110 V control voltage		250 031 72	250 031 72	250 031 72	250 031 72

¹⁾ The necessary motor protection can be provided either by a motor protection switch (supplied and fitted into a panel by others), or with integral motor overload protection (see special equipment).

²⁾ Required for PED (2014/68/EU) compliance.

Country-specific executions and special voltages on application

Special equipment

WM-L10, version R

Oil burners, version R		WM-L10/2-A	WM-L10/3-A	WM-L10/4-A
Pressure gauge with ball valve on pump		210 000 92	210 000 92	210 000 92
Pressure gauge with ball valve in return		210 002 64	210 002 64	210 002 64
Combustion head extension	by 100 mm	210 030 25	210 030 27	210 030 29
	by 200 mm	210 030 26	210 030 28	210 030 30
Oil hoses, 1300 mm in lieu of 1000 mm		210 003 00	210 003 00	210 003 00
Air inlet flange for ducted-air connection with LGW air pressure switch (additional LGW 50 required)	for connection from rear	210 030 20	210 030 20	210 030 20
	for connection from above	250 034 10	250 034 10	250 034 10
	for connection from below	Please enquire	Please enquire	Please enquire
Air inlet flange for ducted-air connection with LGW air pressure switch (in conjunction with electromagnetic clutch)	for connection from rear	250 032 94	250 032 94	250 032 94
	for connection from above	250 033 89	250 033 89	250 033 89
	for connection from below	254 034 89	254 034 89	254 034 89
LGW 50 air pressure switch ³⁾		210 030 08	210 030 08	210 030 08
ST 18/7 and ST 18/4 plug connections (W-FM 50 / 100 / 200)		210 030 13	210 030 13	210 030 13
ST 18/7 plug connection (W-FM 50 with KS20)		250 031 06	250 031 06	250 031 06
Burner-mounted KS20 controller (W-FM 50)		250 033 15	250 033 15	250 033 15
W-FM 100 (suitable for continuous firing) in lieu of W-FM 50 ³⁾	burner-mounted	210 030 38	210 030 38	210 030 38
	supplied loose	210 030 87	210 030 87	210 030 87
DSB 158 oil pressure switch in supply ³⁾		210 030 23	210 030 23	210 030 23
QRI flame sensor in lieu of QRB ³⁾		210 030 24	210 030 24	210 030 24
Integral load controller and analogue signal convertor for W-FM 100		110 017 18	110 017 18	110 017 18
W-FM 200 in lieu of W-FM 50 with integral load controller, analogue signal convertor, and VSD module, with optional fuel metering		210 030 39	210 030 39	210 030 39
VSD with integral frequency convertor (W-FM 50 / 200 required) ¹⁾		210 030 11	210 030 11	210 030 11
VSD with separate frequency convertor (W-FM 200 required) ¹⁾ (See accessories list for frequency convertor)		210 030 12	210 030 12	210 030 12
W-FM 200 with extended CO / FGR functionality		250 033 78	250 033 78	250 033 78
WM-D90 motor with 230 V contactor and overload protection ²⁾		250 030 86	250 030 86	250 030 86
ABE with Chinese-character display, supplied loose (W-FM 100 / 200)		110 018 53	110 018 53	110 018 53
110 V control voltage		250 031 72	250 031 72	250 031 72

¹⁾ VSD with R-version burners:

- General conditions for modulating capacity regulation when firing on oil:
- Frequency: min. 35 Hz
 - Turndown: max. 3:1 (limitations on burner size 10/4)

²⁾ The necessary motor protection can be provided either by a motor protection switch (supplied and fitted into a panel by others), or with integral motor overload protection (see special equipment).

³⁾ Required for PED (2014/68/EU) compliance.

Country-specific executions and special voltages on application

Special equipment WM-G10, version ZM

Gas burners, version ZM		WM-G10/1-A	WM-G10/2-A	WM-G10/3-A	WM-G10/4-A
Combustion head extension	by 100 mm	250 030 00	250 030 03	250 030 06	250 030 09
	by 200 mm	250 030 01	250 030 04	250 030 07	250 030 10
	by 300 mm	250 030 02	250 030 05	250 030 08	250 030 11
Solenoid valve for air pressure switch test with continuous-run fan or post-purge		250 030 21	250 030 21	250 030 21	250 030 21
High gas pressure switch ²⁾ (Screwed W-MF / DMV for low-pressure supplies)	GW 50 A6/1	250 033 30	250 033 30	250 033 30	250 033 30
	GW 150 A6/1	250 033 31	250 033 31	250 033 31	250 033 31
	GW 500 A6/1	250 033 32	250 033 32	250 033 32	250 033 32
High gas pressure switch ²⁾ (Flanged DMV for low-pressure supplies)	GW 50 A6/1	150 017 49	150 017 49	150 017 49	150 017 49
	GW 150 A6/1	150 017 50	150 017 50	150 017 50	150 017 50
	GW 500 A6/1	150 017 51	150 017 51	150 017 51	150 017 51
High gas pressure switch ²⁾ (Fitted to high-pressure regulator)	GW 50 A6/1	250 033 33	250 033 33	250 033 33	250 033 33
	GW 150 A6/1	250 033 34	250 033 34	250 033 34	250 033 34
	GW 500 A6/1	250 033 35	250 033 35	250 033 35	250 033 35
ST 18/7 and ST 18/4 plug connections (W-FM50 / 100 / 200)		250 030 22	250 030 22	250 030 22	250 030 22
ST 18/7 plug connection (W-FM 50 with KS20)		250 031 06	250 031 06	250 031 06	250 031 06
Air inlet flange for ducted-air connection with LGW air pressure switch	for connection from rear	250 030 24	250 030 24	250 030 24	250 030 24
	for connection from above	Please enquire	Please enquire	Please enquire	Please enquire
	for connection from below	250 034 88	250 034 88	250 034 88	250 034 88
ST 18/7 plug connection (W-FM50 with KS20)		250 033 15	250 033 15	250 033 15	250 033 15
W-FM 100 in lieu of W-FM50	burner-mounted	250 030 74	250 030 74	250 030 74	250 030 74
	supplied loose	250 030 45	250 030 45	250 030 45	250 030 45
Integral load controller & analogue signal convertor for W-FM 100		110 017 18	110 017 18	110 017 18	110 017 18
W-FM200 in lieu of W-FM50 with integral load controller, analogue signal convertor, and VSD module, with optional fuel metering	burner-mounted	250 030 75	250 030 75	250 030 75	250 030 75
	supplied loose	250 030 48	250 030 48	250 030 48	250 030 48
VSD with integral frequency convertor (W-FM50 / 200 required)		210 030 11	210 030 11	210 030 11	210 030 11
VSD with separate frequency convertor (W-FM200 required) (See accessories list for frequency convertor)		210 030 12	210 030 12	210 030 12	210 030 12
W-FM200 with extended CO / FGR functionality		250 033 78	250 033 78	250 033 78	250 033 78
WM-D90 motor with 230 V contactor and overload protection ¹⁾		250 030 86	250 030 86	250 030 86	250 030 86
ABE with Chinese-character display, supplied loose (W-FM 100 / 200)		110 018 53	110 018 53	110 018 53	110 018 53
110 V control voltage		250 031 72	250 031 72	250 031 72	250 031 72
Offset gas butterfly valve and gas valve assembly for vertical firing		250 032 96	250 032 96	250 032 96	250 032 96

¹⁾ The necessary motor protection can be provided either by a motor protection switch (supplied and fitted into a panel by others), or with integral motor overload protection (see special equipment).

²⁾ Required for PED (2014/68/EU) compliance.

Country-specific executions and special voltages on application

Special equipment

WM-G10, version ZM-LN

Gas burners, version ZM-LN		WM-G10/1-A	WM-G10/2-A	WM-G10/3-A	WM-G10/4-A
Combustion head extension	by 100 mm	250 030 12	250 030 15	250 030 18	250 030 18
	by 200 mm	250 030 13	250 030 16	250 030 19	250 030 19
	by 300 mm	250 030 14	250 030 17	250 030 20	250 030 20
Solenoid valve for air pressure switch test with continuous-run fan or post-purge		250 030 21	250 030 21	250 030 21	250 030 21
High gas pressure switch ²⁾ (Screwed W-MF / DMV for low-pressure supplies)	GW 50 A6/1	250 033 30	250 033 30	250 033 30	250 033 30
	GW 150 A6/1	250 033 31	250 033 31	250 033 31	250 033 31
	GW 500 A6/1	250 033 32	250 033 32	250 033 32	250 033 32
High gas pressure switch ²⁾ (Flanged DMV for low-pressure supplies)	GW 50 A6/1	150 017 49	150 017 49	150 017 49	150 017 49
	GW 150 A6/1	150 017 50	150 017 50	150 017 50	150 017 50
	GW 500 A6/1	150 017 51	150 017 51	150 017 51	150 017 51
High gas pressure switch ²⁾ (Fitted to high-pressure regulator)	GW 50 A6/1	250 033 33	250 033 33	250 033 33	250 033 33
	GW 150 A6/1	250 033 34	250 033 34	250 033 34	250 033 34
	GW 500 A6/1	250 033 35	250 033 35	250 033 35	250 033 35
ST 18/7 and ST 18/4 plug connections (W-FM 50 / 100 / 200)		250 030 22	250 030 22	250 030 22	250 030 22
ST 18/7 plug connection (W-FM 50 with KS20)		250 031 06	250 031 06	250 031 06	250 031 06
Air inlet flange for ducted-air connection with LGW air pressure switch	for connection from rear	250 030 24	250 030 24	250 030 24	250 030 24
	for connection from above	Please enquire	Please enquire	Please enquire	Please enquire
	for connection from below	250 034 88	250 034 88	250 034 88	250 034 88
Burner-mounted KS20 controller (W-FM 50)		250 033 15	250 033 15	250 033 15	250 033 15
W-FM 100 in lieu of W-FM 50	burner-mounted	250 030 74	250 030 74	250 030 74	–
	supplied loose	250 030 45	250 030 45	250 030 45	–
Integral load controller & analogue signal convertor for W-FM 00		110 017 18	110 017 18	110 017 18	–
W-FM 200 in lieu of W-FM 50 with integral load controller, analogue signal convertor, and VSD module, with optional fuel metering	burner-mounted	250 030 75	250 030 75	250 030 75	250 030 75
	supplied loose	250 030 48	250 030 48	250 030 48	250 030 48
VSD with integral frequency convertor (W-FM 50 / 200 required)		210 030 11	210 030 11	210 030 11	Standard
VSD with separate frequency convertor (W-FM 200 required) (See accessories list for frequency convertor)		210 030 12	210 030 12	210 030 12	Please enquire
W-FM 200 with extended CO / FGR functionality		250 033 78	250 033 78	250 033 78	250 033 78
WM-D90 motor with 230 V contactor and overload protection ¹⁾		250 030 86	250 030 86	250 030 86	–
ABE with Chinese-character display, loose (W-FM 100 / 200)		110 018 53	110 018 53	110 018 53	110 018 53
110 V control voltage		250 031 72	250 031 72	250 031 72	250 031 72
Offset gas butterfly valve and gas valve assembly for vertical firing		250 032 96	250 032 96	250 032 96	250 032 96

¹⁾ The necessary motor protection can be provided either by a motor protection switch (supplied and fitted into a panel by others), or with integral motor overload protection (see special equipment).

²⁾ Required for PED (2014/68/EU) compliance.

Country-specific executions and special voltages on application

Special equipment WM-GL10, version ZM-T

Dual-fuel burners, version ZM-T		WM-GL10/1-A	WM-GL10/2-A	WM-GL10/3-A	WM-GL10/4-A
Combustion head extension	by 100 mm	250 030 50	250 030 53	250 030 56	250 030 59
	by 200 mm	250 030 51	250 030 54	250 030 57	250 030 60
	by 300 mm	250 030 52	250 030 55	250 030 58	250 030 61
Solenoid valve for air pressure switch test with continuous-run fan or post-purge		250 030 21	250 030 21	250 030 21	250 030 21
High gas pressure switch ²⁾ (Screwed W-MF / DMV for low-pressure supplies)	GW 50 A6/1	250 033 30	250 033 30	250 033 30	250 033 30
	GW 150 A6/1	250 033 31	250 033 31	250 033 31	250 033 31
	GW 500 A6/1	250 033 32	250 033 32	250 033 32	250 033 32
High gas pressure switch ²⁾ (Flanged DMV for low-pressure supplies)	GW 50 A6/1	150 017 49	150 017 49	150 017 49	150 017 49
	GW 150 A6/1	150 017 50	150 017 50	150 017 50	150 017 50
	GW 500 A6/1	150 017 51	150 017 51	150 017 51	150 017 51
High gas pressure switch ²⁾ (Fitted to high-pressure regulator)	GW 50 A6/1	250 033 33	250 033 33	250 033 33	250 033 33
	GW 150 A6/1	250 033 34	250 033 34	250 033 34	250 033 34
	GW 500 A6/1	250 033 35	250 033 35	250 033 35	250 033 35
ST 18/7 and ST 18/4 plug connections (W-FM54)		250 031 99	250 031 99	250 031 99	250 031 99
ST 18/7 and ST 18/4 plug connections (W-FM 100 / 200)		250 032 01	250 032 01	250 032 01	250 032 01
Oil hoses, 1300 mm in lieu of 1000 mm		210 003 00	210 003 00	210 003 00	210 003 00
VZ08 oil meter without transmitter with additional safety shutoff device		250 030 46	250 030 46	250 030 46	250 030 46
VZ08 oil meter with low-frequency transmitter for external wiring		250 030 47	250 030 47	250 030 47	250 030 47
VZ08 oil meter with high-frequency transmitter for internal wiring (W-FM54 or W-FM200)		250 032 50	250 032 50	250 032 50	250 032 50
Two-stage in lieu of three-stage (low-impact start / changeover)		210 030 31	210 030 31	210 030 31	210 030 31
Electromagnetic clutch		250 030 44	250 030 44	250 030 44	250 030 44
Air inlet flange for ducted-air connection with LGW air pressure switch	for connection from rear	210 030 20	210 030 20	210 030 20	210 030 20
	for connection from above	250 034 10	250 034 10	250 034 10	250 034 10
	for connection from below	Please enquire	Please enquire	Please enquire	Please enquire
Air inlet flange for ducted-air connection (in conjunction with electromagnetic clutch)	for connection from rear	250 032 94	250 032 94	250 032 94	250 032 94
	for connection from above	250 033 89	250 033 89	250 033 89	250 033 89
	for connection from below	254 034 89	254 034 89	254 034 89	254 034 89
DSB 158 oil pressure switch in supply ²⁾ (W-FM 100 / 200 required)		250 030 82	250 030 82	250 030 82	250 030 82
W-FM 100 (suitable for continuous firing) in lieu of W-FM 54, with integral load controller and analogue signal convertor ²⁾	burner-mounted	250 031 78	250 031 78	250 031 78	250 031 78
	supplied loose	250 031 93	250 031 93	250 031 93	250 031 93
W-FM 200 in lieu of W-FM 54 with integral load controller, analogue signal convertor and VSD module, with optional fuel metering	burner-mounted	250 031 77	250 031 77	250 031 77	250 031 77
	supplied loose	250 031 62	250 031 62	250 031 62	250 031 62
VSD with integral frequency convertor (W-FM 54 / 200 required)		210 030 11	210 030 11	210 030 11	210 030 11
VSD with separate frequency convertor (W-FM 200 required) (See accessories list for frequency convertor)		210 030 12	210 030 12	210 030 12	210 030 12
W-FM 200 with extended CO / FGR functionality		250 033 78	250 033 78	250 033 78	250 033 78
WM-D90 motor with 230 V contactor and overload protection ¹⁾		250 030 86	250 030 86	250 030 86	250 030 86
ABE with Chinese-character display, loose (W-FM 100 / 200)		110 018 53	110 018 53	110 018 53	110 018 53
110 V control voltage (W-FM 100 / 200 only)		250 031 72	250 031 72	250 031 72	250 031 72
Offset gas butterfly valve and gas valve assembly for vertical firing		250 032 96	250 032 96	250 032 96	250 032 96

¹⁾ The necessary motor protection can be provided either by a motor protection switch (supplied and fitted into a panel by others), or with integral motor overload protection (see special equipment).

²⁾ Required for PED (2014/68/EU) compliance.

Country-specific executions and special voltages on application

Special equipment

WM-GL10, version ZM-R

Dual-fuel burners, version ZM-R		WM-GL10/2-A	WM-GL10/3-A	WM-GL10/4-A
Combustion head extension	by 100 mm	250 030 62	250 030 65	250 030 68
	by 200 mm	250 030 63	250 030 66	250 030 69
	by 300 mm	250 030 64	250 030 67	250 030 70
Solenoid valve for air pressure switch test with continuous-run fan or post-purge		250 030 21	250 030 21	250 030 21
High gas pressure switch ³⁾ (Screwed W-MF / DMV for low-pressure supplies)	GW 50 A6/1	250 033 30	250 033 30	250 033 30
	GW 150 A6/1	250 033 31	250 033 31	250 033 31
	GW 500 A6/1	250 033 32	250 033 32	250 033 32
High gas pressure switch ³⁾ (Flanged DMV / VGD for low-pressure supplies)	GW 50 A6/1	150 017 49	150 017 49	150 017 49
	GW 150 A6/1	150 017 50	150 017 50	150 017 50
	GW 500 A6/1	150 017 51	150 017 51	150 017 51
High gas pressure switch ³⁾ (Fitted to high-pressure regulator)	GW 50 A6/1	250 033 33	250 033 33	250 033 33
	GW 150 A6/1	250 033 34	250 033 34	250 033 34
	GW 500 A6/1	250 033 35	250 033 35	250 033 35
ST 18/7 and ST 18/4 plug connections (W-FM 54 / 100 / 200)		250 030 22	250 030 22	250 030 22
Oil hoses, 1300 mm in lieu of 1000 mm		210 003 00	210 003 00	210 003 00
Air inlet flange for ducted-air connection (in conjunction with electromagnetic clutch)	for connection from rear	250 032 94	250 032 94	250 032 94
	for connection from above	250 033 89	250 033 89	250 033 89
	for connection from below	250 034 89	250 034 89	250 034 89
DSB 158 oil pressure switch in supply ³⁾ (W-FM 100 / 200 required)		210 030 23	210 030 23	210 030 23
W-FM 100 (suitable for continuous firing) ³⁾ in lieu of W-FM 54	burner-mounted	250 031 76	250 031 76	250 031 76
	supplied loose	250 031 82	250 031 82	250 031 82
Integral load controller and analogue signal convertor for W-FM 100		110 017 18	110 017 18	110 017 18
W-FM 200 in lieu of W-FM 54 with integral load controller, analogue signal convertor and VSD module with optional fuel metering	burner-mounted	250 031 77	250 031 77	250 031 77
	supplied loose	250 031 63	250 031 63	250 031 63
VSD with integral frequency convertor (W-FM 54 / 200 required) ¹⁾		210 030 11	210 030 11	210 030 11
VSD with separate frequency convertor (W-FM 200 required) ¹⁾ (See accessories list for frequency convertor)		210 030 12	210 030 12	210 030 12
W-FM 200 with extended CO / FGR functionality		250 033 78	250 033 78	250 033 78
WM-D90 motor with 230 V contactor and overload protection ²⁾		250 030 86	250 030 86	250 030 86
ABE with Chinese-character display, supplied loose (W-FM 100 / 200)		110 018 53	110 018 53	110 018 53
110 V control voltage (W-FM 100 / 200 only)		250 031 72	250 031 72	250 031 72
Offset gas butterfly valve and gas valve assembly for vertical firing		250 032 96	250 032 96	250 032 96

¹⁾ VSD with R-version burners:

- General conditions for modulating capacity regulation when firing on oil:
- Frequency: min. 35 Hz
 - Turndown: max. 3:1 (limitations on burner sizes 10/3 & 10/4)

²⁾ The necessary motor protection can be provided either by a motor protection switch (supplied and fitted into a panel by others), or with integral motor overload protection (see special equipment).

³⁾ Required for PED (2014/68/EU) compliance.

Country-specific executions and special voltages on application

Technical data

Oil burners

Oil burners		WM-L10/1-A T	WM-L10/2-A T WM-L10/2-A R	WM-L10/3-A T WM-L10/3-A R	WM-L10/4-A T WM-L10/4-A R
Burner motor	Weishaupt type	WM-D 90/90-2/1K0	WM-D 90/90-2/1K0	WM-D 90/110-2/1K5	WM-D 90/110-2/1K5
Motor power output	kW	0.9	0.9	1.5	1.5
Nominal current	A	2.2	2.2	3.2	3.2
Burner without VSD: Motor protection switch ¹⁾ or motor prefusing ¹⁾ (with overload protection)	type (e.g.) A minimum	PKE12/XTU - 4 10 A gG/T (by others)	PKE12/XTU - 4 10 A gG/T (by others)	PKE12/XTU - 4 16 A gG/T (by others)	PKE12/XTU - 4 16 A gG/T (by others)
Burner with VSD: Motor protection switch ²⁾ or motor prefusing ²⁾	type (e.g.) A minimum	PKE12/XTU - 4 10 A gG/T (by others)	PKE12/XTU - 4 10 A gG/T (by others)	PKE12/XTU - 12 10 A gG/T (by others)	PKE12/XTU - 12 10 A gG/T (by others)
Speed (50 Hz)	rpm	2900	2900	2900	2900
Combustion manager	type	W-FM50	W-FM50	W-FM50	W-FM50
Flame monitoring	type	QRB	QRB	QRB	QRB
Air damper / oil actuator	type	STE 50	STE 50	STE 50	STE 50
Integral pump max. flow rate	type	AL 75C	AL 75C	AL 95C	AL 95C
	l/h	130	130	130	150
	type	–	AJV4	AJV6	AJV6
	l/h	–	200	290	290
NO _x Class per EN 267		2	2	2	2
Oil hoses	DN / length	8 / 1000	8 / 1000	8 / 1000	8 / 1000
Mass	kg (T)	approx. 51	approx. 51	approx. 54	approx. 54
	(R)	–	approx. 59	approx. 62	approx. 62

¹⁾ The necessary motor protection can be provided either by a motor protection switch (supplied and fitted into a panel by others), or with integral motor overload protection (see special equipment).

²⁾ The necessary motor protection can be provided either by a motor protection switch or with motor prefusing (supplied and fitted into a panel by others).

Voltages and frequencies:

The burners are equipped as standard for three-phase alternating current, 400 V, 3 ~, 50 Hz. Other voltages and frequencies are available on application.

Standard burner motor:

Insulation Class F, IP 55 protection.
IE3 Premium Efficiency.

Technical data

Gas burners

Gas burners		WM-G10/1-A ZM	WM-G10/2-A ZM	WM-G10/3-A ZM	WM-G10/4-A ZM
Burner motor	Weishaupt type	WM-D 90/90-2/1K0	WM-D 90/90-2/1K0	WM-D 90/110-2/1K5	WM-D 90/110-2/1K5
Motor power output	kW	0.9	0.9	1.5	1.5
Nominal current	A	2.2	2.2	3.2	3.2
Burner without VSD: Motor protection switch ¹⁾ or motor prefusing ¹⁾ (with overload protection)	type (e.g.) A minimum	PKE12/XTU - 4 10 A gG/T (by others)	PKE12/XTU - 4 10 A gG/T (by others)	PKE12/XTU - 4 16 A gG/T (by others)	PKE12/XTU - 4 16 A gG/T (by others)
Burner with VSD: Motor protection switch ²⁾ or motor prefusing ²⁾	type (e.g.) A minimum	PKE12/XTU - 4 10 A gG/T (by others)	PKE12/XTU - 4 10 A gG/T (by others)	PKE12/XTU - 12 10 A gG/T (by others)	PKE12/XTU - 12 10 A gG/T (by others)
Speed (50 Hz)	rpm	2900	2900	2900	2900
Combustion manager	type	W-FM50	W-FM50	W-FM50	W-FM50
Flame monitoring	type	ION	ION	ION	ION
Air damper / oil actuator	type	STE 50	STE 50	STE 50	STE 50
NO _x Class per EN 676	ZM	2	2	2	2
Mass	kg	approx. 55	approx. 55	approx. 60	approx. 60

Gas burners		WM-G10/1-A ZM-LN	WM-G10/2-A ZM-LN	WM-G10/3-A ZM-LN	WM-G10/4-A ZM-LN
Burner motor	Weishaupt type	WM-D 90/90-2/1K0	WM-D 90/90-2/1K0	WM-D 90/110-2/1K5	WM-D 90/110-2/1K9
Motor power output	kW	0.9	0.9	1.5	1.9
Nominal current	A	2.2	2.2	3.2	3.7
Burner without VSD: Motor protection switch ¹⁾ or motor prefusing ¹⁾ (with overload protection)	type (e.g.) A minimum	PKE12/XTU - 4 10 A gG/T (by others)	PKE12/XTU - 4 10 A gG/T (by others)	PKE12/XTU - 4 16 A gG/T (by others)	- -
Burner with VSD: Motor protection switch ²⁾ or motor prefusing ²⁾	type (e.g.) A minimum	PKE12/XTU - 4 10 A gG/T (by others)	PKE12/XTU - 4 10 A gG/T (by others)	PKE12/XTU - 12 10 A gG/T (by others)	PKE12/XTU - 12 10 A gG/T (by others)
Speed (50 Hz)	rpm	2900	2900	2900	3120 (55 Hz)
Combustion manager	type	W-FM50	W-FM50	W-FM50	W-FM50
Flame monitoring	type	ION	ION	ION	ION
Air damper / oil actuator	type	STE 50	STE 50	STE 50	STE 50
NO _x Class per EN 676	ZM-LN	3	3	3	3
Mass	kg	approx. 55	approx. 55	approx. 60	approx. 60

¹⁾ The necessary motor protection can be provided either by a motor protection switch (supplied and fitted into a panel by others), or with integral motor overload protection (see special equipment).

²⁾ The necessary motor protection can be provided either by a motor protection switch or with motor prefusing (supplied and fitted into a panel by others).

Voltages and frequencies:

The burners are equipped as standard for three-phase alternating current, 400 V, 3 ~, 50 Hz. Other voltages and frequencies are available on application.

Standard burner motor:

Insulation Class F, IP 55 protection.
IE3 Premium Efficiency.

Technical data

Dual-fuel burners

Dual-fuel burners		WM-GL10/1-A ZM-T	WM-GL10/2-A ZM-T	WM-GL10/3-A ZM-T	WM-GL10/4-A ZM-T
Burner motor	Weishaupt type	WM-D 90/90-2/1K0	WM-D 90/90-2/1K0	WM-D 90/110-2/1K5	WM-D 90/110-2/1K5
Motor power output	kW	0.9	0.9	1.5	1.5
Nominal current	A	2.2	2.2	3.2	3.2
Burner without VSD: Motor protection switch ¹⁾ or motor prefusing ¹⁾ (with overload protection)	type (e.g.) A minimum	PKE12/XTU - 4 10 A gG/T (by others)	PKE12/XTU - 4 10 A gG/T (by others)	PKE12/XTU - 4 16 A gG/T (by others)	PKE12/XTU - 4 16 A gG/T (by others)
Burner with VSD: Motor protection switch ²⁾ or motor prefusing ²⁾	type (e.g.) A minimum	PKE12/XTU - 4 10 A gG/T (by others)	PKE12/XTU - 4 10 A gG/T (by others)	PKE12/XTU - 12 10 A gG/T (by others)	PKE12/XTU - 12 10 A gG/T (by others)
Speed (50 Hz)	rpm	2900	2900	2900	2900
Combustion manager	type	W-FM 54	W-FM 54	W-FM 54	W-FM 54
Flame monitoring		QRA2	QRA2	QRA2	QRA2
Air damper / oil actuator	type	STE 50	STE 50	STE 50	STE 50
NO _x Class per EN 267 / EN 676		2/2	2/2	2/2	2/2
Mass	kg	approx. 65	approx. 65	approx. 70	approx. 70
Integral pump max. flow rate	type l/h	AL75 130	AL75 130	AL95 150	AJ6 290
Oil hoses	DN / length	8 / 1000	8 / 1000	8 / 1000	8 / 1000

Dual-fuel burners		WM-GL10/2-A ZM-R	WM-GL10/3-A ZM-R	WM-GL10/4-A ZM-R
Burner motor	Weishaupt type	WM-D 90/90-2/1K0	WM-D 90/110-2/1K5	WM-D 90/110-2/1K5
Motor power output	kW	1.0	1.5	1.5
Nominal current	A	2.2	3.2	3.2
Burner without VSD: Motor protection switch ¹⁾ or motor prefusing ¹⁾ (with overload protection)	type (e.g.) A minimum	PKE12/XTU - 4 10 A gG/T (by others)	PKE12/XTU - 4 16 A gG/T (by others)	PKE12/XTU - 4 16 A gG/T (by others)
Burner with VSD: Motor protection switch ²⁾ or motor prefusing ²⁾	type (e.g.) A minimum	PKE12/XTU - 4 10 A gG/T (by others)	PKE12/XTU - 12 10 A gG/T (by others)	PKE12/XTU - 12 10 A gG/T (by others)
Speed (50 Hz)	rpm	2900	2900	2900
Combustion manager	type	W-FM 54	W-FM 54	W-FM 54
Flame monitoring		QRA2	QRA2	QRA2
Air damper / oil actuator	type	STE 50	STE 50	STE 50
NO _x Class per EN 676 / EN 267		2/2	2/2	2/2
Mass	kg	approx. 74	approx. 79	approx. 79
Integral pump max. flow rate	type l/h	AJV4 200	AJV6 290	AJV6 290
Oil hoses	DN / length	8 / 1000	8 / 1000	8 / 1000

¹⁾ The necessary motor protection can be provided either by a motor protection switch (supplied and fitted into a panel by others), or with integral motor overload protection (see special equipment).

²⁾ The necessary motor protection can be provided either by a motor protection switch or with motor prefusing (supplied and fitted into a panel by others).

Voltages and frequencies:

The burners are equipped as standard for three-phase alternating current, 400 V, 3 ~, 50 Hz. Other voltages and frequencies are available on application.

Standard burner motor:

Insulation Class F, IP 55 protection.
IE3 Premium Efficiency.

Dimensions

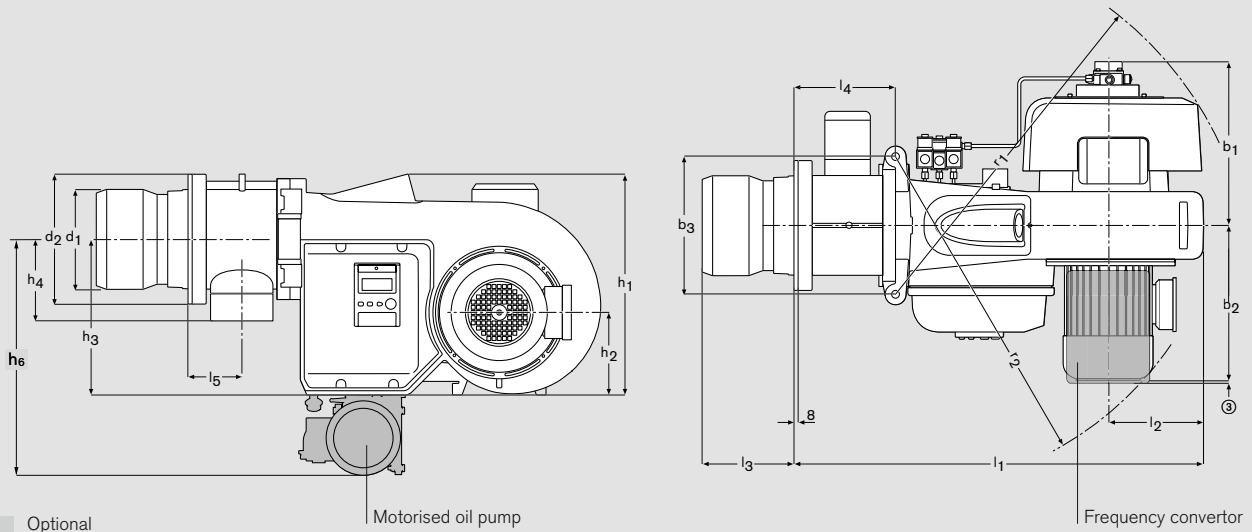

Burner type	Dimensions in mm													
	l ₁	l ₂	l ₃	l ₄	l ₅	b ₁ ^①	b ₂	b ₃	h ₁	h ₂	h ₃	h ₄	h ₅	h ₆
WM-L10/1-A T	659	205	118-138	38	-	323	307	270	445	167	313	-	153	470
WM-L10/2-A T	659	205	127-147	38	-	323	307	270	445	167	313	-	153	470
WM-L10/3-A T	659	205	147-167	38	-	323	335	270	445	167	313	-	153	470
WM-L10/4-A T	659	205	148-168	38	-	323	335	270	445	167	313	-	153	470
WM-L10/2-A R	659	205	131-146	38	-	352	307	270	445	167	313	-	153	480
WM-L10/3-A R	659	205	156-171	38	-	352	335	270	445	167	313	-	153	480
WM-L10/4-A R	659	205	151-166	38	-	352	335	270	445	167	313	-	153	490
WM-G10/1-A ZM	813	205	171-178	188	98	279	307	270	445	167	313	140	153	-
WM-G10/2-A ZM	813	205	158-178	188	98	279	307	270	445	167	313	140	153	-
WM-G10/3-A ZM	833	205	199-224	208	108	279	335	270	445	167	313	162	153	-
WM-G10/4-A ZM	833	205	199-224	208	108	279	335	270	445	167	313	162	153	-
WM-G10/1-A ZM-LN	793	205	129-144	169	88	279	307	270	445	167	313	130	153	-
WM-G10/2-A ZM-LN	813	205	132-143	188	98	279	307	270	445	167	313	140	153	-
WM-G10/3-A ZM-LN	833	205	177-197	208	108	279	335	270	445	167	313	162	153	-
WM-G10/4-A ZM-LN	833	205	177-197	208	108	279	335	270	445	167	313	162	153	-
WM-GL10/1-A ZM-T	813	205	171-178	188	98	323	307	270	445	167	313	140	153	470
WM-GL10/2-A ZM-T	813	205	158-178	188	98	323	307	270	445	167	313	140	153	470
WM-GL10/3-A ZM-T	833	205	199-224	208	108	323	335	270	445	167	313	162	153	470
WM-GL10/4-A ZM-T	833	205	199-224	208	108	323	335	270	445	167	313	162	153	470
WM-GL10/2-A ZM-R	813	205	158-178	188	98	482 ^②	307	270	445	167	313	140	153	480
WM-GL10/3-A ZM-R	833	205	199-224	208	108	482 ^②	335	270	445	167	313	162	153	480
WM-GL10/4-A ZM-R	833	205	199-224	208	108	482 ^②	335	270	445	167	313	162	153	490

① Excluding electromagnetic clutch (pump with electromagnetic clutch: plus 130 mm) ② Including electromagnetic clutch ③ Projection of frequency convertor approx. 20 mm

**Mounting-plate
drilling dimensions**

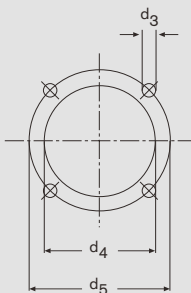

Heat generator preparation

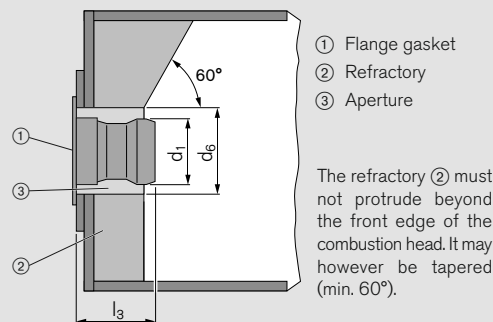

Burner type	Dimensions in mm								Nominal diameter of gas butterfly
	r ₁	r ₂	d ₁	d ₂	d ₃	d ₄	d ₅	d ₆	
WM-L10/1-A T	718	682	140	242	M10	165	186	170	–
WM-L10/2-A T	718	682	140	242	M10	165	186	170	–
WM-L10/3-A T	718	698	160	242	M10	185	210	190	–
WM-L10/4-A T	718	698	180	242	M10	185	210	220	–
WM-L10/2-A R	718	682	160	242	M10	165	186	170	–
WM-L10/3-A R	718	698	180	242	M10	185	210	190	–
WM-L10/4-A R	718	698	180	242	M10	185	210	220	–
WM-G10/1-A ZM	718	682	160	212	M10	165	186	190	DN40
WM-G10/2-A ZM	718	682	160	212	M10	165	186	190	DN40
WM-G10/3-A ZM	718	698	200	260	M10	210	235	240	DN50
WM-G10/4-A ZM	718	698	218	260	M10	220	235	250	DN50
WM-G10/1-A ZM-LN	718	682	127	195	M8	135	160 – 170	160	DN25
WM-G10/2-A ZM-LN	718	682	160	212	M10	165	186	190	DN40
WM-G10/3-A ZM-LN	718	698	200	260	M10	210	235	240	DN50
WM-G10/4-A ZM-LN	718	698	200	260	M10	210	235	240	DN50
WM-GL10/1-A ZM-T	718	682	160	212	M10	165	186	190	DN40
WM-GL10/2-A ZM-T	718	682	160	212	M10	165	186	190	DN40
WM-GL10/3-A ZM-T	718	698	200	260	M10	210	235	240	DN50
WM-GL10/4-A ZM-T	718	698	218	260	M10	220	235	250	DN50
WM-GL10/2-A ZM-R	764	682	160	212	M10	165	186	190	DN40
WM-GL10/3-A ZM-R	764	698	200	260	M10	210	235	240	DN50
WM-GL10/4-A ZM-R	764	698	218	260	M10	220	235	250	DN50

All dimensions are approximate. Weishaupt reserve the right to make changes in light of future developments.

Fuel systems

Gas side fuel system

W-FM 50 / 100 / 200

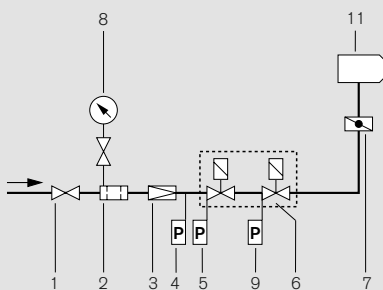

- 1 Ball valve *
- 2 Gas filter *
- 3 Pressure regulator, (LP) or (HP) *
- 4 High gas pressure switch *
- 5 Low gas pressure switch
- 6 Double gas valve assembly
- 7 Gas butterfly valve
- 8 Pressure gauge with push-button valve *
- 9 Valve-proving pressure switch
- 10 Low gas / valve-proving pressure switch
- 11 Burner

W-FM 54

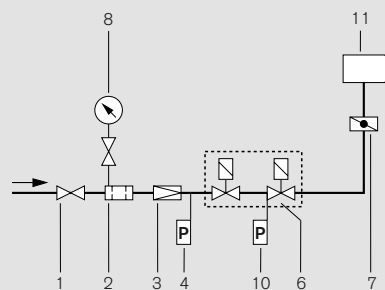

* Not included in burner price

Mounting position of the high gas pressure switch:

- On the regulator outlet of HP trains
- After the regulator of screwed LP trains
- On the valve assembly inlet of flanged LP trains

Cable length approx. 2.5 m.

Layout of the gas valve train

On boilers with hinged doors, the gas valve train must be mounted on the opposite side to the boiler-door hinges.

Compensator

To enable a tension-free mounting of the gas valve train, the fitting of a compensator is strongly recommended.

Break points in the gas valve train

Break points in the gas valve train should be provided to enable the door of the heat generator to be swung open. It is best to separate the main gas line at the compensator.

Support of the gas valve train

The gas valve train should be properly supported in accordance with the site conditions. Please see the Weishaupt accessories list for various gas valve train support components.

Gas meter

A gas meter must be installed to measure gas consumption during commissioning and servicing.

Optional thermal shutoff (if required by local regulations)

The thermal shutoff is integrated into the ball valve of screwed gas valve trains. On flanged gas valve trains the thermal shutoff is a separate component with HTB seals, and is fitted before the ball valve.

Oil side fuel system

Version

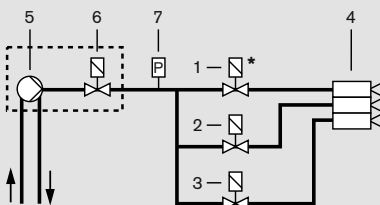

- 1 Stage 1 solenoid valve
- 2 Stage 2 solenoid valve
- 3 Stage 3 solenoid valve
- 4 Nozzle head with 3 oil atomising nozzles
- 5 Burner-mounted oil pump
- 6 Separate safety solenoid valve – WM-GL10/4 only
- 7 Pressure switch in supply (optional)
- * Standard on dual-fuel burners, optional on single-fuel oil burners

Version (ZM-)R

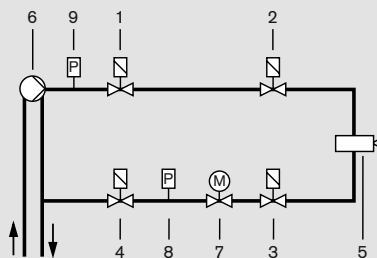

- 1 Normally closed solenoid valve
1st shut-off device in supply
- 2 Normally closed solenoid valve
2nd shut-off device in supply
- 3 Normally closed solenoid valve
1st shut-off device in return
- 4 Normally closed solenoid valve
2nd shut-off device in return
- 5 Nozzle head with regulating nozzle
- 6 Burner-mounted oil pump
- 7 Oil regulator
- 8 Pressure switch in return
- 9 Pressure switch in supply (optional)

ZMI-version Weishaupt monarch[®] burners

More power in compact form



The ZMI version of the Weishaupt WM-G10 monarch[®] burner was developed especially with industrial applications in mind. This burner, with its large turndown range, is designed for use on process plant.

The burner can achieve a turndown of up to 15:1 and its output is matched – within its operating range – to current heat demand.

Zero governor

The ZMI-version WM-G10 gas burner is additionally equipped with a zero governor, which is connected to the burner's airflow upstream of the fan by a flexible impulse line. The zero governor compensates for the drop in gas pressure between partial and full load.

Notes on operation

ZMI-version burners are only suitable for use on process plant when the following fundamental conditions are met:

- The flame must not be impeded within the combustion chamber by process-specific flue gas circulation or by secondary air.
- There must be a flue gas sampling point available prior to dilution by any other sources.
- A flame viewing port must be available.
- A gas flow meter / throughput indicator is essential for setting the burner.
- Additional requirements can be found on datasheet 8-1 in the Weishaupt technical folder.

Use

Fuels

Natural gas
LPG

The suitability of fuels of differing quality must be confirmed in advance with Weishaupt.

Applications

Weishaupt ZMI-version WM-G10 burners are suitable for intermittent firing and continuous firing on:

- EN 303-compliant heat generators
- LTHW boilers
- HTHW boilers
- Steam boilers
- Air heaters
- Process applications

Type approval

The ZMI version of the Weishaupt WM-G10 burner is not type approved. The burner's safety equipment meets the requirements of EN 676.

If an approval inspection is required, this should be arranged with the appropriate body by the plant operator.

Permissible ambient conditions

- Ambient temperature
-15 to +40 °C for gas firing
- Maximum 80 % relative humidity, no condensation
- The combustion air must be free of aggressive substances (halogens, chlorides, fluorides etc.) and impurities (dust, debris, vapours, etc.)
- Adequate ventilation is required for operation in enclosed spaces
- For plant in unheated areas, certain further measures may be required

Use of the burner for other applications or in ambient conditions not detailed above is not permitted without the prior written agreement of Max Weishaupt GmbH. Burner service intervals will be

reduced to accord with the more extreme operational conditions.

Protection Class

IP 54

Gas supply

EN 88-compliant regulators with safety diaphragms are used for low-pressure supplies.

For high-pressure supplies, an EN 334-compliant high-pressure regulator should be selected from the following technical booklets:

- Regulators up to 4 bar, Print No. 83001202
- Regulators with safety devices, Print No. 83197902

Refer to the burner's rating plate for the maximum connection pressure.

Gas valve train design

Low-pressure valve trains are normally used for gas flow pressures up to a maximum of 300 mbar and a maximum operating pressure (MOP) of 500 mbar. This allows for pressure losses between the transfer station and the valve train. Furthermore, it is assumed that the transfer station utilises components (SSV, regulator) that are not of the highest class of accuracy. In individual cases, following consideration and approval by Weishaupt's headquarters, a gas flow pressure of up to 360 mbar can be approved if the appropriate conditions exist.

The supplier must safeguard the gas flow pressure such that it cannot exceed the MOP of the burner's gas valve train.

High-pressure valve trains are normally used for gas flow pressures greater than 300 mbar.

The supplier must safeguard the gas flow pressure such that, in the event of failure, it cannot exceed the maximum incidental pressure (MIP*) of the burner's gas valve train.

*MIP = MOP x 1.1

Standards compliance

The burners are tested by an independent body and fulfil the applicable requirements of the following European Union directives and applied standards:

EMC EMC Directive
2014/30/EU

Applied standards

- EN 61000-6-1 : 2007
- EN 61000-6-2 : 2005
- EN 61000-6-4 : 2007

LVD Low-Voltage Directive
2014/35/EU

Applied standards

- EN 60335-1 : 2010
- EN 60335-2-102 : 2010

MD Machinery Directive
2006/42/EC

Applied standards

- EN 267 Annex J,
- EN 676 Annex J,

PED¹⁾ Pressure Equipment Directive
2014/68/EU

Applied standards

- EN 267 Annex K,
- EN 676 Annex K,
- Conformity assessment procedure: Module B

¹⁾ With the selection of appropriate equipment.

The burners are labelled with:

- CE Mark

Burner selection / gas valve train sizing

WM-G10, version ZMI

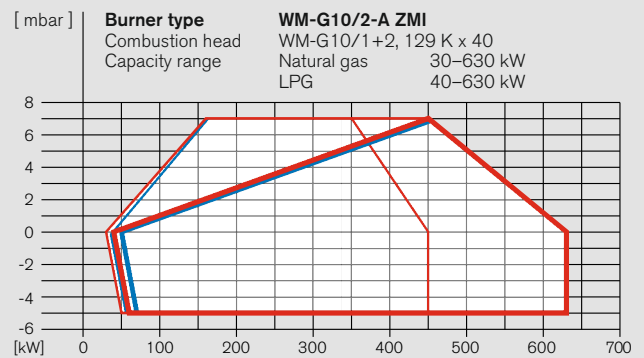
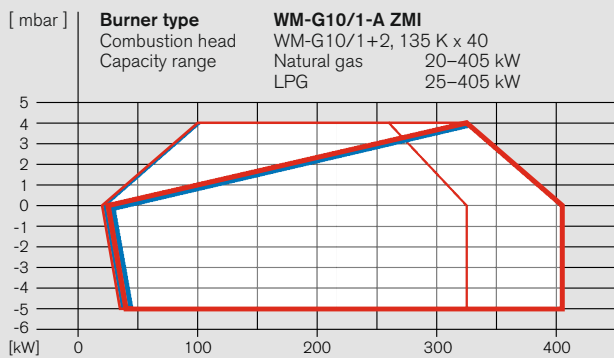

WM-G10/1-A, version ZMI

Burner rating kW	Press. at gas-b/fly at full-load	Low-pressure supply (with FRS regulator)	High-pressure supply (with HP regulator)
		Flow pressure into shutoff valve Nominal valve train diameter Nom. diameter of gas butterfly	F. p. into double valve assembly Nominal valve train diameter Nom. diameter of gas butterfly
		3/4" 1" 1 1/2" 2" 40 40 40 40	3/4" 1" 1 1/2" 2" 40 40 40 40

Natural gas E LHV = 10.35 kWh/m³; d = 0.606; W_i = 13.295 kWh/m³

150	4	15	10	-	-	11	8	7	7
175	4	19	11	8	-	13	9	8	7
200	4	22	12	8	-	15	9	8	7
225	5	27	15	10	-	18	11	9	8
250	6	33	17	11	9	21	12	10	9
275	6	39	20	13	10	25	14	11	10
300	7	45	23	14	11	29	16	13	11
325	8	52	26	16	12	33	18	14	12
350	8	59	29	17	13	36	20	15	12
375	8	66	32	18	13	40	21	15	12
405	9	76	35	19	13	45	23	16	12

Natural gas LL LHV = 8.83 kWh/m³; d = 0.641; W_i = 11.029 kWh/m³

150	4	19	11	8	-	13	9	8	7
175	4	24	13	9	-	16	10	8	7
200	5	30	16	10	-	19	11	9	8
225	5	37	19	11	9	23	13	10	9
250	6	45	22	13	10	28	15	12	10
275	7	53	26	15	12	33	18	13	11
300	8	62	30	17	13	38	20	15	12
325	9	72	34	19	14	44	23	17	13
350	10	82	38	20	15	49	25	17	14
375	10	93	42	22	15	55	27	18	14
405	10	106	47	24	16	62	29	20	14

LPG LHV = 25.89 kWh/m³; d = 1.555; W_i = 20.762 kWh/m³

150	4	10	-	-	-	8	7	7	7
175	4	11	8	-	-	9	7	7	7
200	4	13	9	-	-	10	8	7	7
225	4	15	10	-	-	11	8	7	7
250	4	17	11	8	-	12	9	8	7
275	5	20	12	9	8	14	10	9	8
300	6	23	14	10	9	16	11	10	9
325	7	26	16	11	10	18	12	11	10
350	7	29	17	12	10	20	13	11	10
375	7	32	18	12	10	21	13	11	10
405	7	36	19	12	10	23	14	11	10

Nat. gas: Capacity with comb. head

Closed —
 Open —

LPG: Capacity with comb. head

Closed —
 Open —

Please refer to page 15 for notes on the gas supply.

WM-G10/2-A, version ZMI

Burner rating kW	Press. at gas-b/fly at full-load	Low-pressure supply (with FRS regulator)	High-pressure supply (with HP regulator)
		Flow pressure into shutoff valve Nominal valve train diameter Nom. diameter of gas butterfly	F. p. into double valve assembly Nominal valve train diameter Nom. diameter of gas butterfly
		3/4" 1" 1 1/2" 2" 65 40 40 40 40 40	3/4" 1" 1 1/2" 2" 65 40 40 40 40 40

Natural gas E LHV = 10.35 kWh/m³; d = 0.606; W_i = 13.295 kWh/m³

300	6	44	22	13	10	9	27	15	11	9	6
350	8	58	28	16	12	11	35	19	14	11	8
400	9	75	35	19	14	12	45	23	16	13	10
450	11	93	43	23	16	14	55	27	19	15	11
500	11	112	50	25	17	15	65	31	21	15	11
550	11	132	58	28	18	15	76	35	22	16	12
600	11	155	66	31	19	16	88	39	24	17	12
630	11	170	72	32	19	16	96	42	26	17	12

Natural gas LL LHV = 8.83 kWh/m³; d = 0.641; W_i = 11.029 kWh/m³

300	7	61	29	16	12	11	37	19	14	11	8
350	9	82	38	20	14	13	48	24	17	13	10
400	11	105	47	24	17	15	61	30	20	15	12
450	12	130	58	28	19	16	75	35	23	17	13
500	12	158	68	32	20	17	90	40	26	18	13
550	12	188	79	36	21	17	106	46	28	19	14
600	13	221	92	40	23	18	123	52	31	20	14
630	13	242	100	43	24	19	135	56	33	20	15

LPG LHV = 25.89 kWh/m³; d = 1.555; W_i = 20.762 kWh/m³

300	4	22	12	9	-	-	15	10	8	7	-
350	6	28	15	10	9	8	18	12	10	8	6
400	7	35	19	12	10	9	23	14	11	10	7
450	8	43	23	14	12	11	28	16	13	11	8
500	8	51	25	15	12	11	32	18	14	11	8
550	8	59	29	16	12	11	36	19	14	12	8
600	8	69	32	18	13	11	41	21	15	12	9
630	8	75	34	18	13	12	44	22	16	12	9

The LHV is referenced to 0 °C and 1013 mbar atmospheric. All pressures are in mbar.

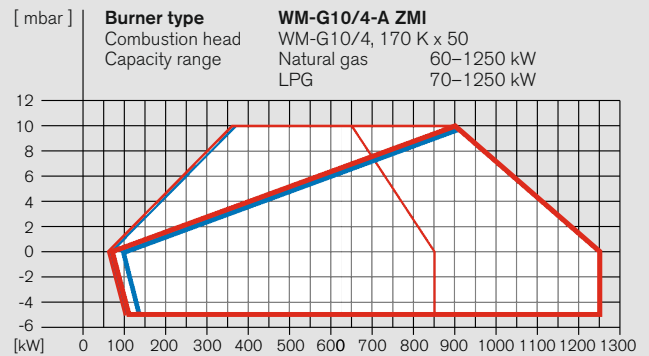
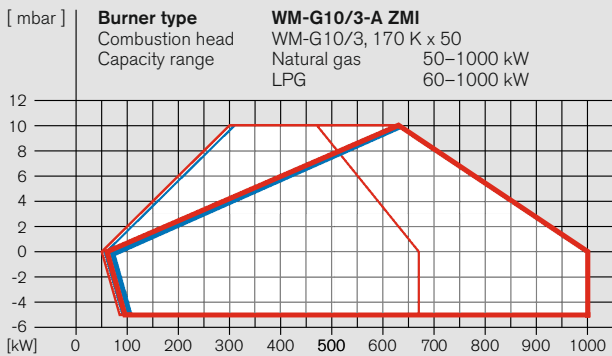

WM-G10/3-A, version ZMI

Burner rating kW	Press. at gas-b/fly at full-load	Low-pressure supply (with FRS regulator) Flow pressure into shutoff valve					High-pressure supply (with HP regulator) F. p. into double valve assembly						
		Nominal valve train diameter					Nominal valve train diameter						
		3/4"	1"	1 1/2"	2"	65	80	3/4"	1"	1 1/2"	2"	65	80
		Nom. diameter of gas butterfly					Nom. diameter of gas butterfly						
		50	50	50	50	50	50	50	50	50	50	50	50

Natural gas E LHV = 10.35 kWh/m³; d = 0.606; W_i = 13.295 kWh/m³

500	7	108	46	21	13	11	10	61	27	17	12	8	7
550	8	130	55	25	15	12	12	73	32	20	13	5	9
600	9	154	64	29	17	14	13	86	37	23	15	10	10
650	10	179	75	33	19	15	14	100	43	26	17	12	11
700	11	206	85	36	21	16	15	115	48	28	18	12	11
750	11	235	96	40	22	17	15	130	53	30	18	13	12
800	11	-	107	44	23	17	15	-	59	33	19	13	12
850	11	-	119	48	24	18	15	-	65	35	20	13	12
900	11	-	132	52	26	18	16	-	71	38	21	14	12
950	11	-	146	56	27	19	16	-	78	41	22	14	13
1000	11	-	160	61	29	20	17	-	85	44	23	14	13

Natural gas LL LHV = 8.83 kWh/m³; d = 0.641; W_i = 11.029 kWh/m³

500	8	154	64	28	16	13	12	86	36	22	14	9	9
550	9	185	76	33	18	14	13	103	43	25	16	11	10
600	11	219	90	38	21	16	15	122	50	29	18	12	11
650	12	-	104	43	24	18	16	-	58	33	20	14	13
700	12	-	119	48	25	19	16	-	65	36	21	14	13
750	12	-	134	53	27	19	17	-	72	39	22	15	13
800	12	-	151	59	29	20	17	-	81	43	23	15	14
850	13	-	169	65	31	21	18	-	89	47	24	16	14
900	13	-	188	71	33	22	19	-	99	51	26	17	15
950	13	-	208	78	35	23	19	-	108	55	27	17	15
1000	13	-	229	85	38	24	20	-	119	60	29	18	16

LPG LHV = 25.89 kWh/m³; d = 1.555; W_i = 20.762 kWh/m³

500	6	48	23	13	10	9	8	29	15	11	9	6	6
550	7	58	27	15	11	10	9	35	18	13	10	7	7
600	7	68	32	17	12	11	10	40	20	14	11	8	8
650	8	79	36	19	13	12	11	47	23	16	12	9	9
700	9	91	41	21	14	13	12	53	26	17	13	10	9
750	9	102	45	22	15	13	12	59	28	18	13	10	9
800	9	115	50	24	15	13	12	66	30	19	14	10	9
850	9	128	55	25	16	13	12	73	32	20	14	10	9
900	9	142	60	27	16	13	12	80	35	21	14	10	9
950	9	157	65	29	17	13	12	88	37	22	14	10	9
1000	9	173	71	31	17	14	12	96	40	24	15	10	9

WM-G10/4-A, version ZMI

Burner rating kW	Press. at gas-b/fly at full-load mbar	Low-pressure supply (with FRS regulator) Flow pressure into shutoff valve					High-pressure supply (with HP regulator) F. p. into double valve assembly				
		Nominal valve train diameter					Nominal valve train diameter				
		1"	1 1/2"	2"	65	80	1"	1 1/2"	2"	65	80
		Nom. diameter of gas butterfly					Nom. diameter of gas butterfly				
		50	50	50	50	50	50	50	50	50	50

Natural gas E LHV = 10.35 kWh/m³; d = 0.606; W_i = 13.295 kWh/m³

600	7	62	26	15	12	10	35	20	13	8	8
700	9	83	34	19	14	13	46	26	16	10	10
800	11	107	43	23	17	15	58	32	19	13	12
900	12	133	53	27	20	17	72	39	22	15	14
1000	14	163	64	31	22	19	87	46	25	17	15
1100	14	194	74	35	24	20	102	53	27	18	16
1200	15	228	86	39	26	21	119	61	30	19	17
1250	15	247	92	41	27	22	128	65	31	20	18

Natural gas LL LHV = 8.83 kWh/m³; d = 0.641; W_i = 11.029 kWh/m³

600	8	87	35	18	14	12	48	26	15	10	9
700	10	117	46	23	17	15	63	34	19	12	11
800	12	151	59	29	20	17	81	43	23	15	14
900	15	189	73	35	24	20	100	53	27	18	16
1000	16	231	87	40	27	23	121	62	31	21	18
1100	17	-	103	46	30	24	-	73	35	22	20
1200	18	-	119	52	33	26	-	84	39	24	21
1250	18	-	128	55	34	27	-	90	41	25	22

LPG LHV = 25.89 kWh/m³; d = 1.555; W_i = 20.762 kWh/m³

600	5	29	14	10	8	-	18	12	9	5	5
700	6	38	18	12	10	9	23	15	11	7	7
800	8	48	22	14	12	11	29	18	12	8	8
900	9	60	27	16	13	12	35	21	14	10	9
1000	10	72	32	18	15	13	41	25	16	11	10
1100	10	85	36	20	15	14	47	27	17	11	11
1200	10	99	40	21	16	14	54	30	18	12	11
1250	10	106	43	22	16	14	58	32	18	12	11

Please refer to page 15 for notes on the gas supply.

The LHV is referenced to 0 °C and 1013 mbar atmospheric. All pressures are in mbar.

Scope of delivery

Order numbers

Description	WM-G10 ZMI
Burner housing, hinged flange, housing cover, Weishaupt burner motor, air inlet housing, fan wheel, combustion head, ignition unit, ignition cable, ignition electrodes, combustion manager with control unit, flame sensor, actuators, flange gasket, limit switch on hinged flange, fixing screws	●
Digital combustion manager	
W-FM50	●
W-FM100	○
W-FM200	○
Valve proving via pressure switch and W-FM	●
Class-A double gas valve assembly	●
Gas butterfly valve	●
Air pressure switch	●
Low gas pressure switch	●
Preset, capacity-based mixing assembly	●
Actuators for compound regulation of fuel and air via W-FM:	
Air damper actuator	●
Gas butterfly valve actuator	●
DOL motor contactor fitted to motor ¹⁾	●
IP 54 protection	●

EN 676 stipulates that ball valves, gas filters, and gas pressure regulators form part of the burner supply (see Weishaupt accessories list).

Gas valve train handing should be confirmed at the time of order.

If not otherwise specified, the burner will be supplied configured for a right-handed gas valve train.

The burner can be altered for the opposite gas valve train handing through rotation of the gas butterfly valve and actuator.

Please enquire or see the special equipment section of this brochure for further burner executions.

- Standard
- Optional

¹⁾ The necessary motor protection can be provided either by a motor protection switch (supplied and fitted into a panel by others), or with integral motor overload protection (see special equipment).

Burner type	Version	Gas valve assembly size	Order No.
WM-G10/1-A	ZMI	R ¾	217 113 10
		R 1	217 113 11
		R 1½	217 113 12
		R 2	217 113 13
WM-G10/2-A	ZMI	R ¾	217 116 10
		R 1	217 116 11
		R 1½	217 116 12
		R 2	217 116 13
		DN 65	217 116 14
WM-G10/3-A	ZMI	R ¾	217 119 10
		R 1	217 119 11
		R 1½	217 119 12
		R 2	217 119 13
		DN 65	217 119 14
		DN 80	217 119 15
WM-G10/4-A	ZMI	R 1	217 121 11
		R 1½	217 121 12
		R 2	217 121 13
		DN 65	217 121 14
		DN 80	217 121 15

Special equipment

Technical data

Gas burners, version ZMI		WM-G10/1-A	WM-G10/2-A	WM-G10/3-A	WM-G10/4-A
Combustion head extension	by 100 mm	250 030 00	250 030 03	250 030 06	250 030 09
	by 200 mm	250 030 01	250 030 04	250 030 07	250 030 10
	by 300 mm	250 030 02	250 030 05	250 030 08	250 030 11
Solenoid valve for air pressure switch test with continuous-run fan or post purge		250 030 21	250 030 21	250 030 21	250 030 21
High gas pressure switch fitted to flanged elbow	GW 50 A6/1	250 007 59	250 007 59	250 007 59	250 007 59
ST 18/7 and ST 18/4 plug connections		250 030 22	250 030 22	250 030 22	250 030 22
Air inlet flange for ducted-air connection with LGW air pressure switch	for connection from rear	250 030 24	250 030 24	250 030 24	250 030 24
	for connection from above	Please enquire	Please enquire	Please enquire	Please enquire
	for connection from below	250 034 88	250 034 88	250 034 88	250 034 88
W-FM 100 in lieu of W-FM 50	burner-mounted	250 034 35	250 034 35	250 034 35	250 034 35
	supplied loose	250 034 36	250 034 36	250 034 36	250 034 36
Integral load controller and analogue signal convertor for W-FM 100		110 017 18	110 017 18	110 017 18	110 017 18
W-FM 200 in lieu of W-FM 50 with integral load controller, analogue signal convertor, and VSD module, with optional fuel metering	burner-mounted	250 034 37	250 034 37	250 034 37	250 034 37
	supplied loose	250 034 38	250 034 38	250 034 38	250 034 38
VSD with integral frequency convertor (W-FM 50/200 required)		210 030 11	210 030 11	210 030 11	210 030 11
VSD with separate frequency convertor (W-FM 200 required) (See accessories list for frequency convertor)		210 030 12	210 030 12	210 030 12	210 030 12
W-FM 200 with extended CO / FGR functionality		250 033 78	250 033 78	250 033 78	250 033 78
WM-D90 motor with 230 V contactor and overload protection ¹⁾		250 030 86	250 030 86	250 030 86	250 030 86
ABE with Chinese-character display, supplied loose		110 018 53	110 018 53	110 018 53	110 018 53
110 V control voltage		250 031 72	250 031 72	250 031 72	250 031 72

Country-specific executions and special voltages on application

Technical data		WM-G10/1-A ZMI	WM-G10/2-A ZMI	WM-G10/3-A ZMI	WM-G10/4-A ZMI
Burner motor	Weishaupt type	WM-D 90/90-2/1K0	WM-D 90/90-2/1K0	WM-D 90/110-2/1K5	WM-D 90/110-2/1K5
Motor power output	kW	0.9	0.9	1.5	1.5
Nominal current	A	2.2	2.2	3.2	3.2
Burner without VSD: Motor protection switch ¹⁾ or motor prefusing ¹⁾ (with overload protection)	type (e.g.)	PKE12/XTU - 4	PKE12/XTU - 4	PKE12/XTU - 4	PKE12/XTU - 4
	A minimum	10 A gG/T (by others)	10 A gG/T (by others)	16 A gG/T (by others)	16 A gG/T (by others)
Burner with VSD Motor protection switch ²⁾ or motor prefusing ²⁾	type (e.g.)	PKE12/XTU - 4	PKE12/XTU - 4	PKE12/XTU - 12	PKE12/XTU - 12
	A minimum	10 A gG/T (by others)	10 A gG/T (by others)	10 A gG/T (by others)	10 A gG/T (by others)
Speed (50 Hz)	rpm	2900	2900	2900	2900
Combustion manager	type	W-FM 50	W-FM 50	W-FM 50	W-FM 50
Flame monitoring	type	ION	ION	ION	ION
Air damper / gas actuator	type	STE 50	STE 50	STE 50	STE 50
Mass (excl. double gas valve assembly, zero governor, and fittings)	kg	approx. 55	approx. 55	approx. 60	approx. 60

¹⁾ The necessary motor protection can be provided either by a motor protection switch (supplied and fitted into a panel by others), or with integral motor overload protection (see special equipment).

²⁾ The necessary motor protection can be provided either by a motor protection switch or with motor prefusing (supplied and fitted into a panel by others).

Voltages and frequencies:

The burners are equipped as standard for three-phase alternating current, 400 V, 3 ~, 50 Hz. Other voltages and frequencies are available on application.

Standard burner motor:

Insulation Class F, IP 55 protection.
IE3 Premium Efficiency.

Dimensions

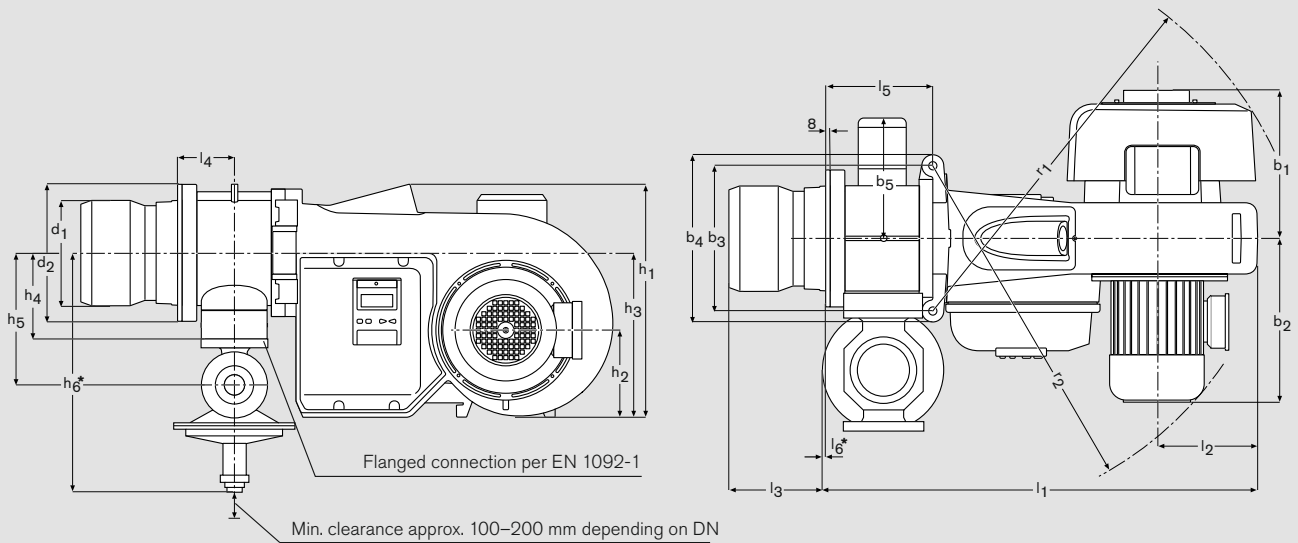

Size	Dimensions in mm													
	l_1	l_2	l_3	l_4	l_5	l_6^* for nom. diameter			h_1	h_2	h_3	h_4	h_5	
						R 2	65	80						
10/1	813	205	171–178	98	188	27	45	45	445	167	313	140	252	
10/2	813	205	158–178	98	188	27	45	45	445	167	313	140	252	
10/3	833	205	199–224	108	208	17	35	35	445	167	313	162	284	
10/4	833	205	199–224	108	228	17	35	35	445	167	313	162	284	

Size	Dimensions in mm																		
	h_6^* for nominal diameter						b_1	b_2	b_3	b_4	b_5	r_1	r_2	d_1	d_2	d_3	d_4	d_5	d_6
	Rp 3/4	Rp 1	Rp 1 1/2	Rp 2	65	80													
10/1	360	380	433	486	–	–	279	307	270	312	232	718	682	160	212	M10	165	186	190
10/2	391	411	464	517	562	–	279	307	270	312	232	718	682	160	212	M10	165	186	190
10/3	435	455	508	561	594	594	279	335	270	312	240	718	698	200	260	M10	210	235	240
10/4	–	455	508	561	594	594	279	335	270	312	240	718	698	218	260	M10	220	235	250

All dimensions are approximate. Weishaupt reserve the right to make changes in light of future developments

* If the protrusion of the zero governor may foul the appliance mounting plate, then a spacer ring must be interposed between the plate and the burner flange (see accessories list). It should be noted that combustion head dimension l_3 is thereby reduced by the depth of the spacer ring.

Heat generator preparation

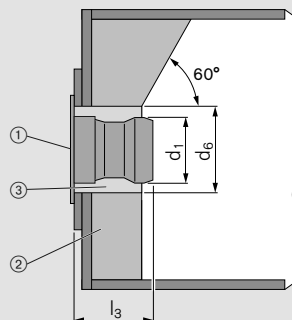

- ① Flange gasket
- ② Refractory
- ③ Aperture

The refractory ② must not protrude beyond the front edge of the combustion head. It may however be tapered (min. 60°).

Mounting-plate drilling dimensions

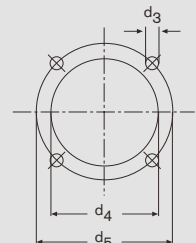

Fuel system

Layout of the valve train

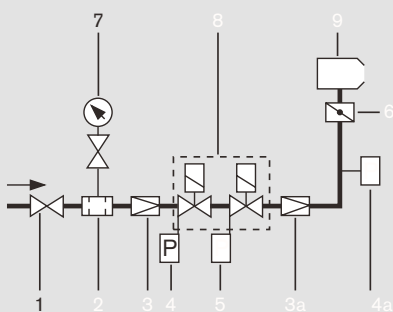

Legend:

- 1 Ball valve *
- 2 Gas filter *
- 3 Pressure regulator, (LP) or (HP) *
- 3a Zero governor with impulse line
- 4 Low gas pressure switch
- 4a High gas pressure switch *
- 5 Valve-proving pressure switch
- 6 Gas butterfly valve
- 7 Pressure gauge with push-button valve *
- 8 Double gas valve assembly
- 9 Burner

* Not included in burner price

Layout of the valve train

On boilers with hinged doors, the valve train must be mounted on the opposite side to the boiler-door hinges.

Compensator

To enable a tension free mounting of the valve train, the fitting of a compensator is strongly recommended.

Break points in the valve train

Break points in the valve train should be provided to enable the door of the heat generator to be swung open. The main gas line is best separated at the compensator.

Support of the valve train

The valve train should be properly supported in accordance with the site conditions. Please refer to the Weishaupt accessories list for various valve train support components.

Gas meter

A gas meter must be installed to measure gas consumption during commissioning and servicing.

Optional thermal shutoff (when required by local regulations)

Integrated into the ball valve of screwed valve trains. A separate component with HTB seals fitted before the ball valve on flanged valve trains.

Saving fuel, reducing emissions: Patented multiflam® technology

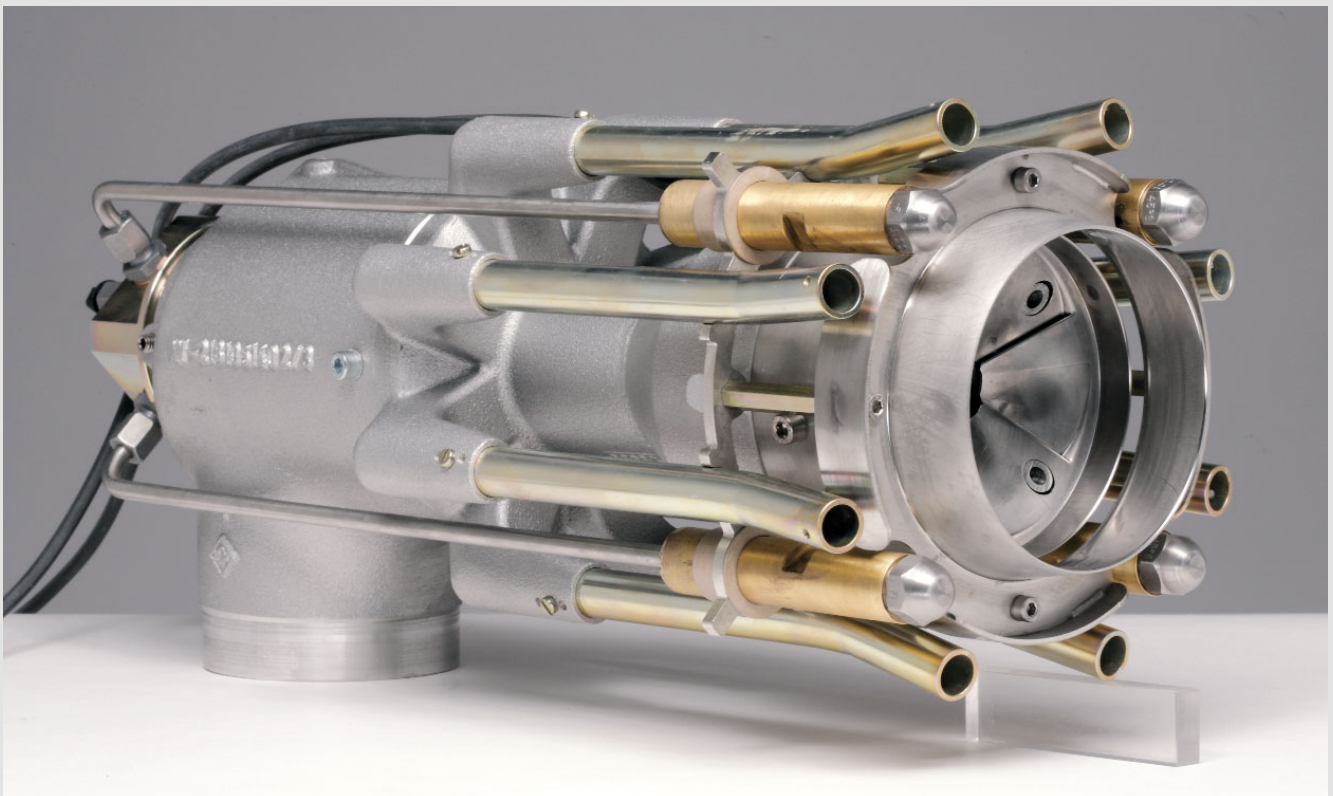

Weishaupt's patented multiflam® technology enables large combustion plant to meet very low emission limits without the need for expensive additional equipment. This reduction in emissions is achieved by using an innovative mixing assembly and fuel distribution system.

Weishaupt multiflam® burners have been proving themselves in the field for 20 years.

The latest monarch® burners bring this technology to medium-capacity ranges, combining flexibility with extremely low emissions.

Flexibility

Gas, oil, and dual-fuel versions of the mixing assembly have been developed. Gas-fired burners have modulating load control, while load control on oil-fired burners is multi-staged.

Exemplary emissions

The NO_x emissions produced by a 3LN-version multiflam® mixing assembly will be considerably lower than those of a standard-version mixing assembly under the same operating conditions. Key is the distribution of fuel among several nozzles and, consequently, its combustion in a primary and a secondary flame. This avoids extremely hot zones in the flame's core which, in turn, greatly reduces the formation of thermal NO_x.

However, the achievement of good combustion figures depends on more than just the burner. Numerous additional parameters, such as the design of the heat generator, and the geometry and the thermal loading of its combustion chamber, are also important. Furthermore, medium temperature, combustion air temperature, and air humidity play a decisive role. When NO_x emissions for a particular application are guaranteed, it will always be with reference to certain constraints and system parameters.

Use

See page 14.

Burner selection

WM-L 10, versions Z-3LN and T-3LN (multiflam®)

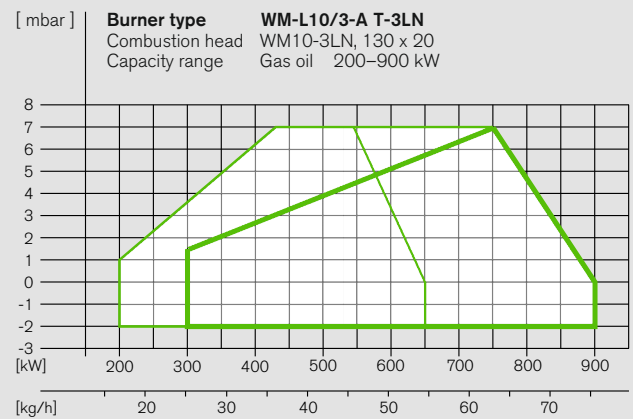
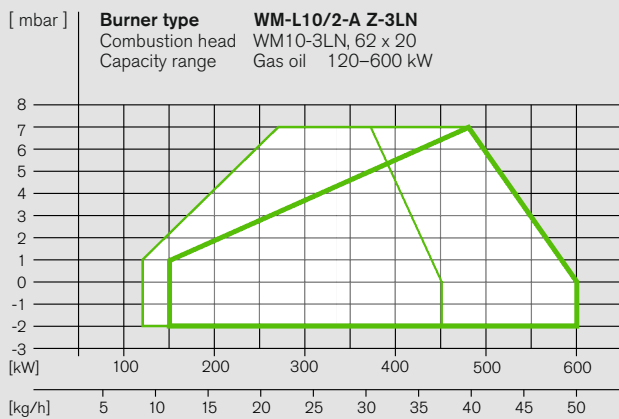

Gas oil: Capacity with combustion head

Closed
 Open

Turndown:

Gas oil max. 3:1

Burner selection

WM-G(L)10, version ZM(-Z)-3LN (multiflam®)

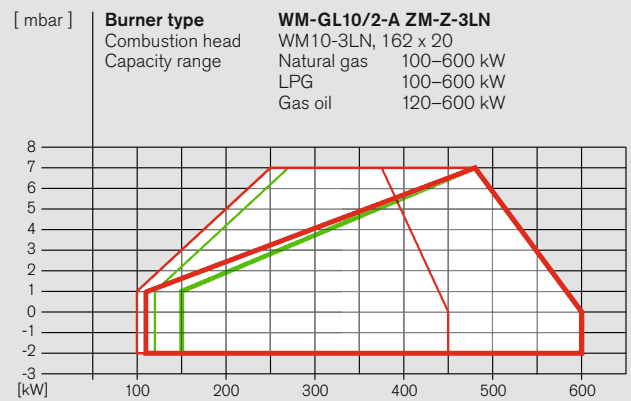
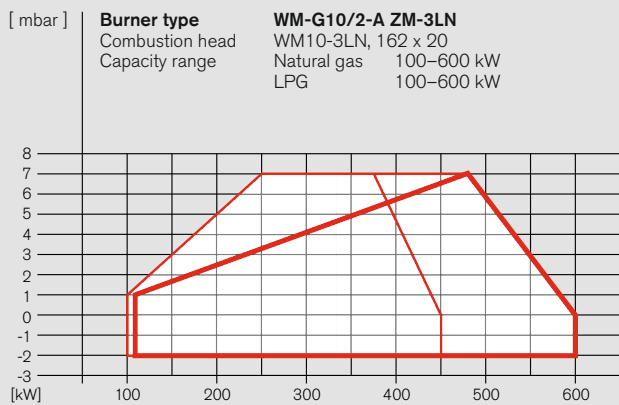

WM-G(L)10/2-A, version ZM(-Z)-3LN (multiflam®)

Burner rating kW	Low-pressure supply (with FRS regulator)					High-pressure supply (with HP regulator)				
	Flow pressure into shutoff valve					F. p. into double valve assembly				
	Nominal valve-train diameter					Nominal valve-train diameter				
	¾"	1"	1½"	2"	65	¾"	1"	1½"	2"	65
	Nominal diameter of gas butterfly					Nominal diameter of gas butterfly				
	50	50	50	50	50	50	50	50	50	50

Natural gas E LHV = 10.35 kWh/m³; d = 0.606; W_i = 13.295 kWh/m³

300	31	16	10	-	-	12	7	6	-	-
350	42	21	13	10	9	16	9	8	7	6
400	53	27	16	12	11	21	12	11	9	8
450	66	32	19	14	13	26	15	13	10	10
500	81	39	22	16	14	31	17	15	12	11
550	96	45	25	18	16	37	20	17	13	13
600	113	52	28	20	18	43	23	20	15	14

Natural gas LL LHV = 8.83 kWh/m³; d = 0.641; W_i = 11.029 kWh/m³

300	43	21	13	10	9	16	9	8	6	6
350	58	28	16	12	11	22	12	11	8	8
400	75	36	20	14	13	29	16	14	11	10
450	93	44	24	17	15	36	19	17	13	12
500	114	53	29	20	18	44	23	20	15	14
550	137	63	33	23	20	52	27	23	18	17
600	161	74	39	26	23	61	32	27	20	19

LPG LHV = 25.89 kWh/m³; d = 1.555; W_i = 20.762 kWh/m³

300	17	11	9	-	-	8	6	5	-	-
350	22	14	10	9	9	10	8	7	6	6
400	28	17	13	11	11	13	10	9	8	8
450	35	21	15	13	13	17	12	11	10	10
500	42	25	18	16	15	20	15	14	12	12
550	50	30	21	18	18	25	18	17	15	15
600	62	38	28	24	23	32	24	23	21	20

Natural gas: Capacity with combustion head

Closed
 Open

Gas oil: Capacity with combustion head

Closed
 Open

Turndown:

Gas max. 6:1
 Gas oil max. 3:1

Burner selection

WM-G(L)10, version ZM(-T)-3LN (multiflam®)

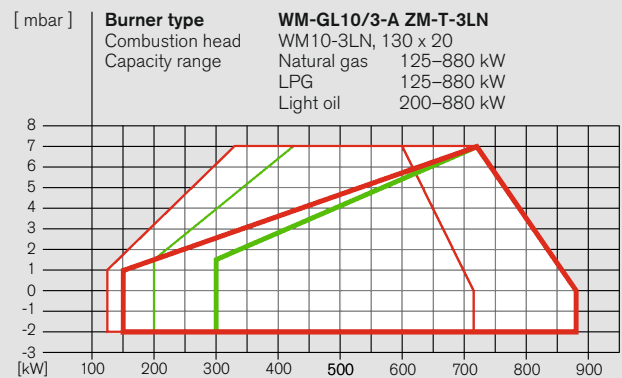
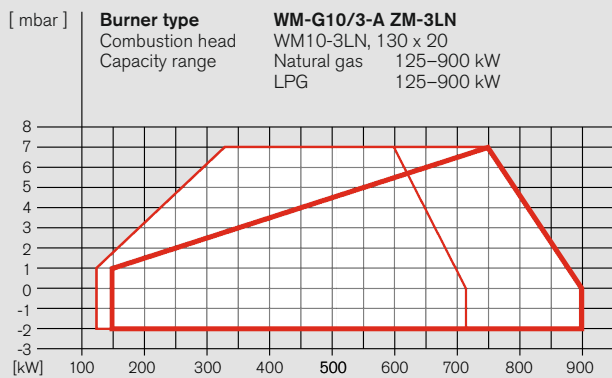

WM-G(L)10/3-A, version ZM(-T)-3LN (multiflam®)

Burner rating kW	Low-pressure supply (with FRS regulator)	High-pressure supply (with HP regulator)
	Flow pressure into shutoff valve	F. p. into double valve assembly
	Nominal valve-train diameter	Nominal valve-train diameter
	¾" 1" 1½" 2" 65 80 100	¾" 1" 1½" 2" 65 80 100
	Nominal diameter of gas butterfly	Nominal diameter of gas butterfly
	50 50 50 50 50 50 50	50 50 50 50 50 50 50

Natural gas E LHV = 10.35 kWh/m³; d = 0.606; W_i = 13.295 kWh/m³

450	66	32	18	14	12	12	12	26	14	12	10	9	9	
500	80	38	21	15	14	13	13	31	17	15	11	11	10	10
550	95	45	24	17	15	15	14	37	19	17	13	12	12	12
600	112	52	28	19	17	16	16	43	22	19	14	13	13	13
650	130	59	31	21	18	17	17	49	25	21	16	15	14	14
700	150	68	35	23	20	19	18	56	28	24	18	16	16	16
750	171	76	38	25	22	20	20	63	31	26	19	18	17	17
800	193	85	42	27	23	22	21	71	35	29	21	19	19	18
850	215	94	45	28	23	22	21	77	36	30	21	19	18	18
900	238	103	48	29	24	22	21	85	39	32	21	19	18	18

Natural gas LL LHV = 8.83 kWh/m³; d = 0.641; W_i = 11.029 kWh/m³

450	92	42	23	16	14	13	13	34	18	15	11	11	10	10
500	112	51	27	18	16	15	14	42	21	18	13	12	12	12
550	134	60	31	20	18	17	16	49	25	21	15	14	13	13
600	158	70	35	23	19	18	18	58	28	24	17	16	15	15
650	184	81	40	25	21	20	19	67	32	27	19	17	17	16
700	212	93	45	28	23	22	21	77	36	30	21	19	18	18
750	242	105	50	30	25	24	22	87	40	33	23	21	20	20
800	274	118	55	33	28	25	24	98	45	37	25	22	22	21
850	-	130	59	34	28	26	24	108	48	39	25	23	22	21
900	-	143	64	36	29	26	24	118	52	41	26	23	22	21

LPG LHV = 25.89 kWh/m³; d = 1.555; W_i = 20.762 kWh/m³

450	34	20	15	13	12	12	12	16	12	11	10	10	9	9
500	42	25	18	15	15	14	14	20	14	13	12	12	12	12
550	50	29	21	18	17	17	17	24	17	16	14	14	14	14
600	58	34	24	20	19	19	19	28	20	19	17	16	16	16
650	68	39	27	23	22	21	21	33	23	21	19	19	19	19
700	77	43	29	25	23	23	23	37	25	23	21	20	20	20
750	85	46	31	25	24	23	23	39	26	24	21	21	20	20
800	94	50	32	26	24	24	23	42	27	25	22	21	21	21
850	103	53	33	26	25	24	23	45	28	26	22	21	21	21
900	113	57	35	27	25	24	24	48	30	27	22	22	21	21

Natural gas: Capacity with combustion head

Closed —
 Open —

Gas oil: Capacity with combustion head

Closed —
 Open —

Turndown:

Gas max. 6:1
 Gas oil max. 3:1

Scope of delivery

Description	WM-L10 3LN	WM-G10 3LN	WM-GL10 3LN
Burner housing, hinged flange, housing cover, Weishaupt burner motor, air inlet housing, fan wheel, combustion head, ignition unit, ignition cable, ignition electrodes, combustion manager with control unit, flame sensor, actuators, flange gasket, limit switch on hinged flange, fixing screws	●	●	●
Digital combustion manager W-FM50 W-FM54	● -	● -	- ●
Valve proving via pressure switch and W-FM	-	●	●
Class-A double gas valve assembly	-	●	●
Gas butterfly valve	-	●	●
Air pressure switch	○	●	●
Low gas pressure switch	-	●	●
Preset, capacity-based mixing assembly	●	●	●
Actuators for compound regulation of fuel and air via W-FM: Air damper actuator Gas butterfly valve actuator	● -	● ●	● ●
Oil pump fitted to burner	●	-	●
Oil hoses	●	-	●
2 (Z-3LN)/3 (T-3LN) oil solenoid valves, nozzle head with pre-installed oil nozzles, 1 additional oil safety solenoid valve	●	-	●
DOL motor contactor fitted to motor ¹⁾	●	●	●
IP 54 protection	●	●	●
Electromagnetic clutch	○	-	○

EN 676 stipulates that ball valves, gas filters, and gas pressure regulators form part of the burner supply (see Weishaupt accessories list).

Gas valve train handing should be confirmed at the time of order.

If not otherwise specified, the burner will be supplied configured for a right-handed gas valve train.

The burner can be altered for the opposite gas valve train handing through rotation of the gas butterfly valve and actuator.

Please enquire or see the special equipment section of this brochure for further burner executions.

- Standard
- Optional

¹⁾ The necessary motor protection can be provided either by a motor protection switch (supplied and fitted into a panel by others), or with integral motor overload protection (see special equipment).

Order numbers

Oil burners

Burner type	Version	Order No.
WM-L10/2-A	Z-3LN	211 110 26
WM-L10/3-A	T-3LN	211 110 34

DIN CERTCO: 5G1010

Dual-fuel burners

Burner type	Version	Gas valve assembly size	Order No.
WM-GL10/2-A	ZM-Z-3LN	R ¾	218 124 10
		R 1	218 124 11
		R 1½	218 124 12
		R 2	218 124 13
		DN 65	218 124 14
WM-GL10/3-A	ZM-T-3LN	R ¾	218 122 10
		R 1	218 122 11
		R 1½	218 122 12
		R 2	218 122 13
		DN 65	218 122 14
		DN 80	218 122 15
	DN 100	218 122 16	

CE-PIN: CE 0085BR0136

DIN CERTCO: 5G1025M

Gas burners

Burner type	Version	Gas valve assembly size	Order No.
WM-G10/2-A	ZM-3LN	R ¾	217 123 10
		R 1	217 123 11
		R 1½	217 123 12
		R 2	217 123 13
		DN 65	217 123 14
WM-G10/3-A	ZM-3LN	R ¾	217 122 10
		R 1	217 122 11
		R 1½	217 122 12
		R 2	217 122 13
		DN 65	217 122 14
		DN 80	217 122 15
		DN 100	217 122 16

CE-PIN: CE 0085BQ0027

Special equipment

WM-L 10, version 3LN (multiflam®)

Oil burners, versions Z-3LN and T-3LN	WM-L10/2-A	WM-L10/3-A
Pressure gauge with ball valve	210 030 18	210 030 18
Vacuum gauge with ball valve	210 030 19	210 030 19
Combustion head extension	by 100 mm Please enquire	250 030 85
	by 200 mm Please enquire	210 030 86
Oil hoses, 1300 mm in lieu of 1000 mm	210 003 00	210 003 00
Electromagnetic clutch	250 030 44	250 030 44
Air inlet flange for ducted air connection with LGW air pressure switch (additional LGW 50 required)	for connection from rear for connection from above for connection from below 210 030 20 250 034 10 Please enquire	210 030 20 250 034 10 Please enquire
Air inlet flange for ducted air connection with LGW air pressure switch (in conjunction with electromagnetic clutch)	for connection from rear for connection from above for connection from below 250 032 94 250 033 89 254 034 89	250 032 94 250 033 89 254 034 89
VZ08 oil meter without transmitter	250 030 46	250 030 46
VZ08 oil meter with low-frequency transmitter for external wiring	250 030 47	250 030 47
ST 18/7 and ST 18/4 plug connections (W-FM50 / 100 / 200)	210 030 13	210 030 13
ST 18/7 plug connection (W-FM50 with KS20)	250 031 06	250 031 06
Burner-mounted KS20 controller (W-FM50)	250 033 15	250 033 15
W-FM 100 (suitable for continuous firing) in lieu of W-FM50 ²⁾	210 030 32	210 030 32
DSB 158 oil pressure switch in supply ²⁾	210 030 23	210 030 23
QRA 73 flame sensor in lieu of QRA 2 ²⁾	210 031 63	210 031 63
LGW 50 air-pressure switch ²⁾	210 030 08	210 030 08
Integral load controller and analogue signal convertor for W-FM 100	110 017 18	110 017 18
W-FM200 in lieu of W-FM50 with integral load controller, analogue signal convertor, and VSD module, with optional fuel metering	210 030 10	210 030 10
W-FM200 with extended CO / FGR functionality	250 033 78	250 033 78
WM-D90 motor with 230 V contactor and overload protection ¹⁾	250 030 86	250 030 86
ABE with Chinese-character display, supplied loose (W-FM 100 / 200)	110 018 53	110 018 53
110 V control voltage	Please enquire	250 031 72

¹⁾ The necessary motor protection can be provided either by a motor protection switch (supplied and fitted into a panel by others), or with integral motor overload protection (see special equipment).

²⁾ Required for PED (2014/68/EU) compliance.

Country-specific executions and special voltages on application

Special equipment WM-G10, version 3LN (multiflam®)

Gas burners, version ZM-3LN		WM-G10/2-A	WM-G10/3-A
Combustion head extension	by 100 mm	Please enquire	250 031 57
	by 200 mm	Please enquire	250 031 58
Solenoid valve for air-pressure switch test with continuous-run fan or post purge		250 030 21	250 030 21
High gas pressure switch ²⁾ (Screwed W-MF / DMV for low-pressure supplies)	GW 50 A6/1	250 033 30	250 033 30
	GW 150 A6/1	250 033 31	250 033 31
	GW 500 A6/1	250 033 32	250 033 32
High gas pressure switch ²⁾ (Flanged DMV for low-pressure supplies)	GW 50 A6/1	150 017 49	150 017 49
	GW 150 A6/1	150 017 50	150 017 50
	GW 500 A6/1	150 017 51	150 017 51
High gas pressure switch ²⁾ (Fitted to high-pressure regulator)	GW 50 A6/1	250 033 33	250 033 33
	GW 150 A6/1	250 033 34	250 033 34
	GW 500 A6/1	250 033 35	250 033 35
ST 18/7 and ST 18/4 plug connections (W-FM50/100/200)		250 030 22	250 030 22
Air inlet flange for ducted-air connection with LGW air pressure switch	for connection from rear	250 030 24	250 030 24
	for connection from above	Please enquire	Please enquire
	for connection from below	250 034 88	250 034 88
Burner-mounted KS20 controller (W-FM50)		250 033 15	250 033 15
W-FM 100 (suitable for continuous firing) in lieu of W-FM 50 ²⁾		250 030 74	250 030 74
Integral load controller and analogue signal convertor for W-FM 100		110 017 18	110 017 18
W-FM 200 in lieu of W-FM 50 with integral load controller, analogue signal convertor, and VSD module, with optional fuel metering		250 030 75	250 030 75
VSD with integral frequency convertor (W-FM 50 / 200 required) ¹⁾		210 030 11	210 030 11
VSD with separate frequency convertor (W-FM 200 required) (See accessories list for frequency convertor) ¹⁾		210 030 12	210 030 12
W-FM 200 with extended CO / FGR functionality		250 033 78	250 033 78
WM-D90 motor with 230 V contactor and overload protection ²⁾		250 030 86	250 030 86
ABE with Chinese-character display, supplied loose (W-FM 100 / 200)		110 018 53	110 018 53
110 V control voltage		Please enquire	250 031 72

¹⁾ The necessary motor protection can be provided either by a motor protection switch (supplied and fitted into a panel by others), or with integral motor overload protection (see special equipment).

²⁾ Required for PED (2014/68/EU) compliance.

Country-specific executions and special voltages on application

Special equipment

WM-GL10, version 3LN (multiflam®)

Dual-fuel burners, versions ZM-Z-3LN and ZM-T-3LN		WM-GL10/2-A	WM-GL10/3-A
Pressure gauge with ball valve		210 030 18	210 030 18
Vacuum gauge with ball valve		210 030 19	210 030 19
Combustion head extension	by 100 mm	Please enquire	250 031 59
	by 200 mm	Please enquire	250 031 60
Solenoid valve for air-pressure switch test with continuous-run fan or post purge		250 030 21	250 030 21
High gas pressure switch ²⁾ (Screwed W-MF / DMV for low-pressure supplies)	GW 50 A6/1	250 033 30	250 033 30
	GW 150 A6/1	250 033 31	250 033 31
	GW 500 A6/1	250 033 32	250 033 32
High gas pressure switch ²⁾ (Flanged DMV for low-pressure supplies)	GW 50 A6/1	150 017 49	150 017 49
	GW 150 A6/1	150 017 50	150 017 50
	GW 500 A6/1	150 017 51	150 017 51
High gas pressure switch ²⁾ (Fitted to high-pressure regulator)	GW 50 A6/1	250 033 33	250 033 33
	GW 150 A6/1	250 033 34	250 033 34
	GW 500 A6/1	250 033 35	250 033 35
Oil hoses, 1300 mm in lieu of 1000 mm		210 003 00	210 003 00
VZ08 oil meter without transmitter		250 030 46	250 030 46
VZ08 oil meter with low-frequency transmitter for external wiring		250 030 47	250 030 47
Electromagnetic clutch		250 030 44	250 030 44
ST 18/7 and ST 18/4 plug connections(W-FM 54)		250 031 99	250 031 99
ST 18/7 plug connection (W-FM 100 / 200)		250 032 01	250 032 01
Air inlet flange for ducted air connection with LGW air pressure switch (additional LGW 50 required)	for connection from rear	210 030 20	210 030 20
	for connection from above	250 034 10	250 034 10
	for connection from below	Please enquire	Please enquire
Air inlet flange for ducted air connection with LGW air pressure switch (in conjunction with electromagnetic clutch)	for connection from rear	250 032 94	250 032 94
	for connection from above	250 033 89	250 033 89
	for connection from below	254 034 89	254 034 89
DSB 158 oil pressure switch in supply ²⁾		250 030 82	250 030 82
QRA 73 flame sensor in lieu of QRA 2 ²⁾		210 031 63	210 031 63
W-FM 100 (suitable for continuous firing) in lieu of W-FM 54, with integral load controller and analogue signal convertor	burner-mounted	250 033 67	250 033 67
	supplied loose	250 033 68	250 033 68
W-FM 200 in lieu of W-FM 54 with integral load controller, analogue signal convertor, and VSD module, with optional fuel metering	burner-mounted	250 033 69	250 033 69
	supplied loose	250 033 70	250 033 70
VSD with integral frequency convertor (W-FM 200 required)		210 030 11	210 030 11
VSD with separate frequency convertor (W-FM 200 required) (See accessories list for frequency convertor)		210 030 12	210 030 12
W-FM 200 with extended CO / FGR functionality		250 033 78	250 033 78
WM-D90 motor with 230 V contactor and overload protection ¹⁾		250 030 86	250 030 86
ABE with Chinese-character display, supplied loose (W-FM 100 / 200)		110 018 53	110 018 53
110 V control voltage	(W-FM 50 / 100 / 200)	Please enquire	250 031 72

¹⁾ The necessary motor protection can be provided either by a motor protection switch (supplied and fitted into a panel by others), or with integral motor overload protection (see special equipment).

²⁾ Required for PED (2014/68/EU) compliance.

Country-specific executions and special voltages on application

Technical data

WM-L 10, version 3LN (multiflam®)

Oil burners		WM-L10/2-A Z-3LN	WM-L10/3-A T-3LN
Burner motor	Weishaupt type	WM-D 90/90-2/1K0	WM-D 90/110-2/1K5
Motor power output	kW	0.9	1.5
Nominal current	A	2.2	3.2
Burner without VSD Motor protection switch ¹⁾ or motor prefusing ¹⁾ (with overload protection)	type (e.g.) A minimum	PKE12/XTU - 4 10 A gG/T (by others)	PKE12/XTU - 4 16 A gG/T (by others)
Burner with VSD Motor protection switch ²⁾ or motor prefusing ²⁾	type (e.g.) A minimum	PKE12/XTU - 4 10 A gG/T (by others)	PPKE12/XTU - 12 10 A gG/T (by others)
Speed (50 Hz)	rpm	2900	2900
Combustion manager	type	W-FM50	W-FM50
Flame monitoring	type	QRA2	QRA2
Integral pump max. flow rate	type l/h	AL 75C 130	AL 95C 150
NOx Class per EN 267		3	3
Oil hoses	DN / length	8 / 1000	8 / 1000
Mass	kg	approx. 65	approx. 68

¹⁾ The necessary motor protection can be provided either by a motor protection switch (supplied and fitted into a panel by others), or with integral motor overload protection (see special equipment).

²⁾ The necessary motor protection can be provided either by a motor protection switch or with motor prefusing (supplied and fitted into a panel by others).

Voltages and frequencies:

The burners are equipped as standard for three-phase alternating current, 400 V, 3 ~, 50 Hz. Other voltages and frequencies are available on application.

Standard burner motor:

Insulation Class F, IP 55 protection.
IE3 Premium Efficiency.

Technical data

WM-G10, version 3LN (multiflam®)

Gas burners		WM-G10/2-A ZM-3LN	WM-G10/3-A ZM-3LN
Burner motor	Weishaupt type	WM-D 90/90-2/1K0	WM-D 90/110-2/1K5
Motor power output	kW	0.9	1.5
Nominal current	A	2.2	3.2
Burner without VSD Motor protection switch ¹⁾ or motor prefusing ¹⁾ (with overload protection)	type (e.g.) A minimum	PKE12/XTU - 4 10 A gG/T (by others)	PKE12/XTU - 4 16 A gG/T (by others)
Burner with VSD Motor protection switch ²⁾ or motor prefusing ²⁾	type (e.g.) A minimum	PKE12/XTU - 4 10 A gG/T (by others)	PPKE12/XTU - 12 10 A gG/T (by others)
Speed (50 Hz)	rpm	2900	2900
Combustion manager	type	W-FM50	W-FM50
Flame monitoring	type	ION	ION
Air damper / oil actuator	type	STE 50	STE 50
NO _x Class per EN 676		3	3
Mass (excl. double gas valve assembly and fittings)	kg	approx. 60	approx. 63

¹⁾ The necessary motor protection can be provided either by a motor protection switch (supplied and fitted into a panel by others), or with integral motor overload protection (see special equipment).

²⁾ The necessary motor protection can be provided either by a motor protection switch or with motor prefusing (supplied and fitted into a panel by others).

Voltages and frequencies:

The burners are equipped as standard for three-phase alternating current, 400 V, 3 ~, 50 Hz. Other voltages and frequencies are available on application.

Standard burner motor:

Insulation Class F, IP 55 protection.
IE3 Premium Efficiency.

Technical data

WM-GL10, version 3LN (multiflam®)

Dual-fuel burners		WM-GL10/2-A ZM-Z-3LN	WM-GL10/3-A ZM-T-3LN
Burner motor	Weishaupt type	WM-D 90/90-2/1K0	WM-D 90/110-2/1K5
Motor power output	kW	0.9	1.5
Nominal current	A	2.2	3.2
Burner without VSD Motor protection switch ¹⁾ or motor prefusing ¹⁾ (with overload protection)	type (e.g.) A minimum	PKE12/XTU - 4 10 A gG/T (by others)	PKE12/XTU - 4 16 A gG/T (by others)
Burner with VSD Motor protection switch ²⁾ or motor prefusing ²⁾	type (e.g.) A minimum	PKE12/XTU - 4 10 A gG/T (by others)	PPKE12/XTU - 12 10 A gG/T (by others)
Speed (50 Hz)	rpm	2900	2900
Combustion manager	type	W-FM54	W-FM54
Flame monitoring type		QRA2	QRA2
Air damper / oil actuator	type	STE 50	STE 50
Integral pump max. flow rate	type l/h	AL 75C 130	AL 95C 150
NO _x Class per EN 267 / EN 676		3	3
Oil hoses	DN / length	8 / 1000	8 / 1000
Mass (excl. double gas valve assembly and fittings)	kg	approx. 70	approx. 73

¹⁾ The necessary motor protection can be provided either by a motor protection switch (supplied and fitted into a panel by others), or with integral motor overload protection (see special equipment).

²⁾ The necessary motor protection can be provided either by a motor protection switch or with motor prefusing (supplied and fitted into a panel by others).

Voltages and frequencies:

The burners are equipped as standard for three-phase alternating current, 400 V, 3 ~, 50 Hz. Other voltages and frequencies are available on application.

Standard burner motor:

Insulation Class F, IP 55 protection.
IE3 Premium Efficiency.

Dimensions

multiflam® oil burners, version 3LN

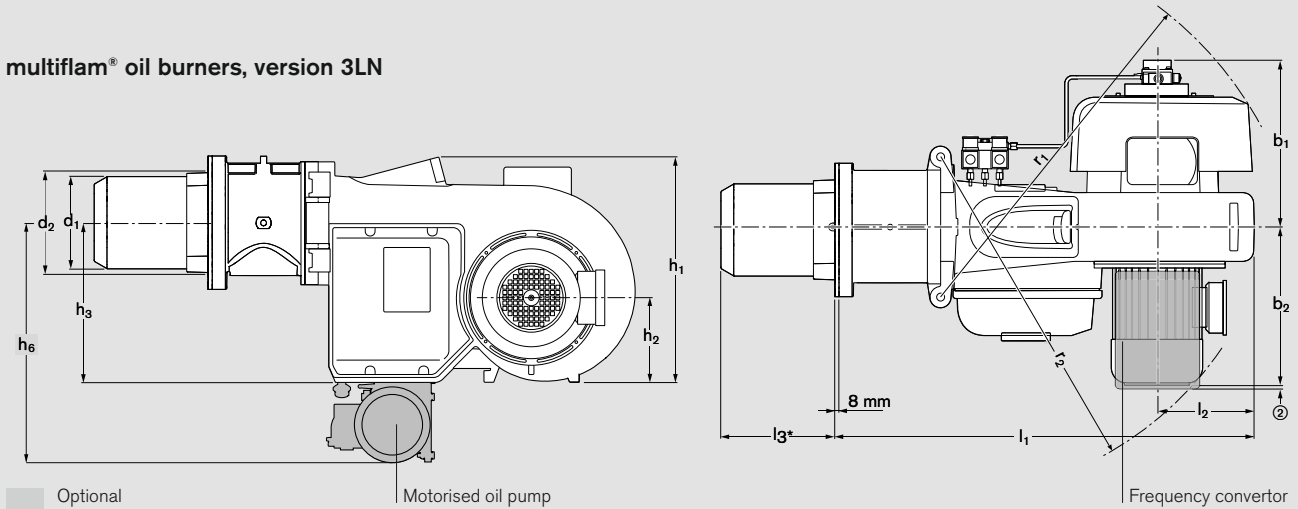

Burner type	Dimensions in mm			b ₁ ^①	b ₂	h ₁	h ₂	h ₃	h ₆	r ₁	r ₂	d ₁	d ₂
	l ₁	l ₂	l ₃										
WM-L10/2 Z-3LN	833	205	209-219	323	307	445	167	313	470	718	682	180	199
WM-L10/3 T-3LN	833	205	207-222	323	335	445	167	313	470	718	698	180	199

① Excluding electromagnetic clutch (pump with electromagnetic clutch: plus 130 mm)

② Projection of frequency converter approx. 20 mm

multiflam® gas burners, version 3LN

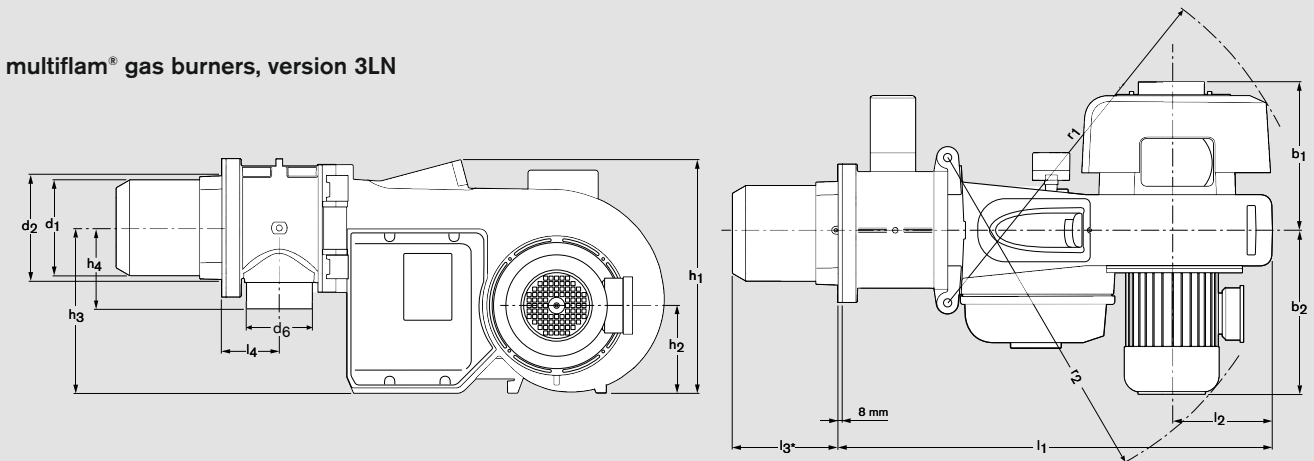

Burner type	Dimensions in mm			l ₄	b ₁	b ₂	h ₁	h ₂	h ₃	h ₄	r ₁	r ₂	d ₁	d ₂	d ₆
	l ₁	l ₂	l ₃												
WM-G10/2 ZM-3LN	833	205	209-219	108	279	307	445	167	313	161	718	682	180	199	DN50
WM-G10/3 ZM-3LN	833	205	212-222	108	279	335	445	167	313	161	718	698	180	199	DN50

All dimensions are approximate. Weishaupt reserve the right to make changes in light of future developments.

multiflam® dual-fuel burners, version 3LN

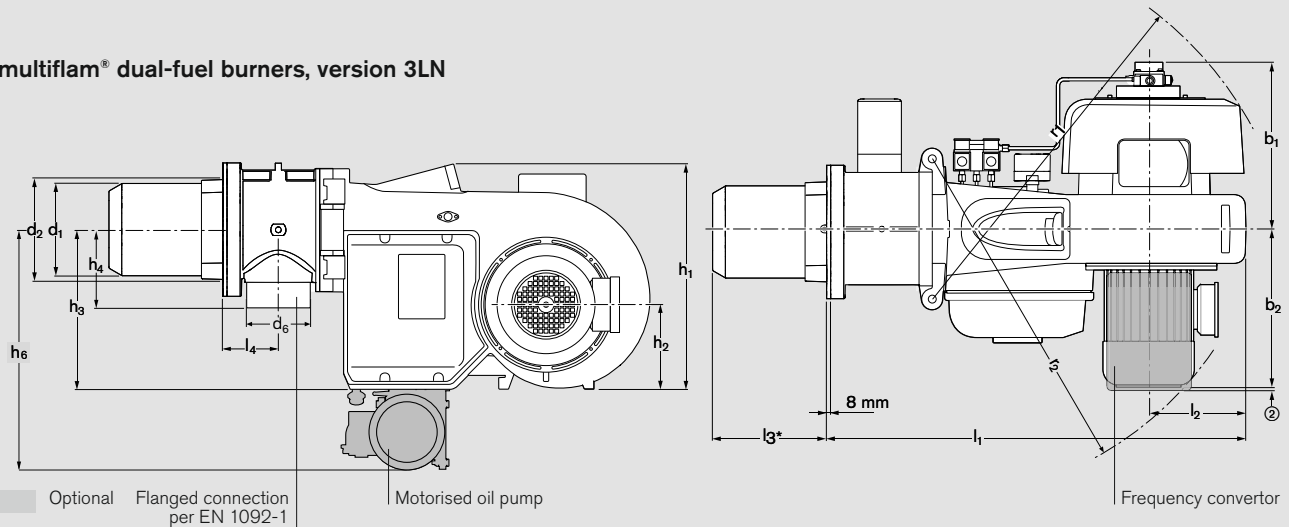

Burner type	Dimensions in mm			l ₄	b ₁	b ₂	h ₁	h ₂	h ₃	h ₄	h ₆	r ₁	r ₂	d ₁	d ₂	d ₆
	l ₁	l ₂	l ₃													
WM-GL10/2 ZM-Z-3LN	833	205	209–219	108	323	307	445	167	313	161	470	718	682	180	199	DN50
WM-GL10/3 ZM-T-3LN	833	205	212–222	108	323	335	445	167	313	161	470	718	698	180	199	DN50

① Excluding electromagnetic clutch (pump with electromagnetic clutch: plus 130 mm)

② Projection of frequency convertor approx. 20 mm

Mounting-plate drilling dimensions

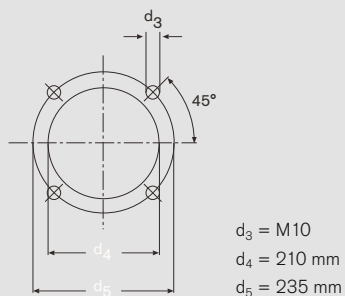

Heat generator preparation

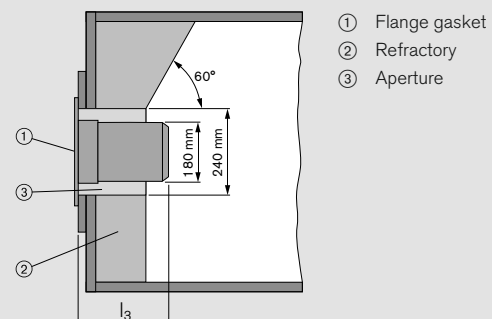

The leading edge of the combustion head must protrude approx. 50 mm beyond the refractory ②. The refractory may be tapered (min. 60°).

All dimensions are approximate. Weishaupt reserve the right to make changes in light of future developments.

Dimensions of ducted-air connection

Gas, oil, and dual-fuel burners

Connection from rear

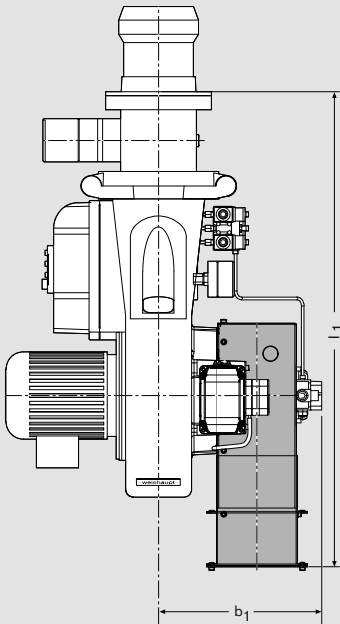

Dimension b_1 identical to standard air inlet housing

Connection from above

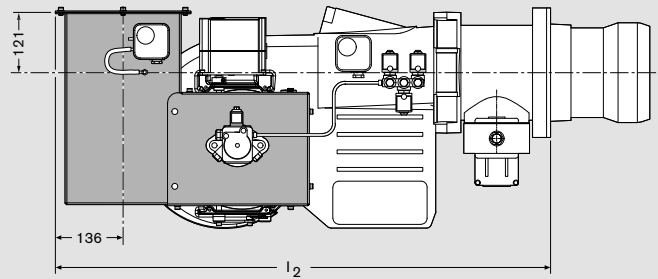

Connection from below

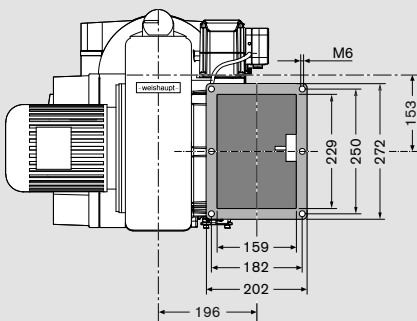
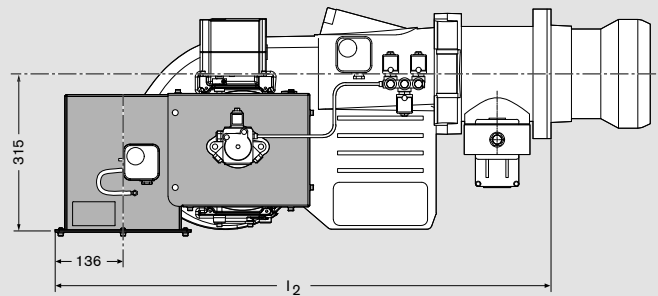

Inlet flange dimensions identical for all versions.

Burner type	Version	Dimensions in mm	
		l_1	l_2
WM-L10/2 to 10/3	3LN	970	994
WM-L10/1 to 10/4		796	820
WM-G10/1	LN	930	954
WM-G(L)10/2	3LN	970	994
WM-G(L)10/1 to 10/2		950	974
WM-G(L)10/3 to 10/4		970	994

All dimensions are approximate.
Weishaupt reserve the right to make changes in light of future developments.

Fuel systems

Gas-side fuel system

W-FM 50 / 100 / 200

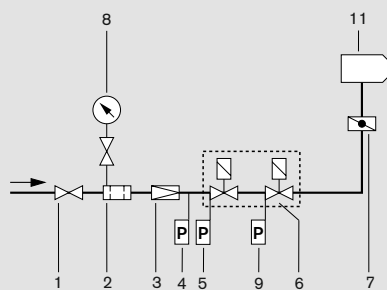

- 1 Ball valve *
- 2 Gas filter *
- 3 Pressure regulator, (LP) or (HP) *
- 4 High gas pressure switch *
- 5 Low gas pressure switch
- 6 Double gas valve assembly
- 7 Gas butterfly valve
- 8 Pressure gauge with push-button valve *
- 9 Valve-proving pressure switch
- 10 Low gas / valve-proving pressure switch
- 11 Burner

Layout of the valve train

On boilers with hinged doors, the valve train must be mounted on the opposite side to the boiler-door hinges.

Compensator

To enable a tension free mounting of the valve train, the fitting of a compensator is strongly recommended.

Break points in the valve train

Break points in the valve train should be provided to enable the door of the heat generator to be swung open. The main gas line is best separated at the compensator.

W-FM 54

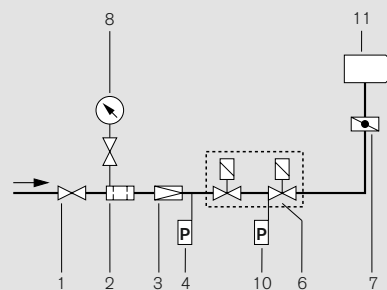

* Not included in burner price

Mounting position of the high gas pressure switch:

- On the regulator outlet of HP trains
- After the regulator of screwed LP trains
- On the valve assembly inlet of flanged LP trains

Cable length approx. 2.5 m.

Support of the valve train

The valve train should be properly supported in accordance with the site conditions. Please refer to the Weishaupt accessories list for various valve train support components.

Gas meter

A gas meter must be installed to measure gas consumption during commissioning and servicing.

Optional thermal shutoff (when required by local regulations)

Integrated into the ball valve of screwed valve trains. A separate component with HTB seals fitted before the ball valve on flanged valve trains.

Oil-side fuel system

WM-(G)L10/2-A (ZM-)Z-3LN:

P = Primary nozzle

1 = Secondary nozzle 1

2 = Secondary nozzle 2

3 = Secondary nozzle 3

4 = Secondary nozzle 4

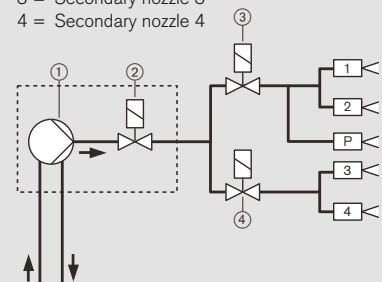

- ① Burner-mounted oil pump
- ② Oil pump solenoid valve
- ③ Ignition load / stage 1 solenoid valve (three-nozzle ignition)
- ④ Stage 2 solenoid valve

WM-(G)L10/3-A (ZM-)T-3LN:

P = Primary nozzle

1 = Secondary nozzle 1

2 = Secondary nozzle 2

3 = Secondary nozzle 3

4 = Secondary nozzle 4

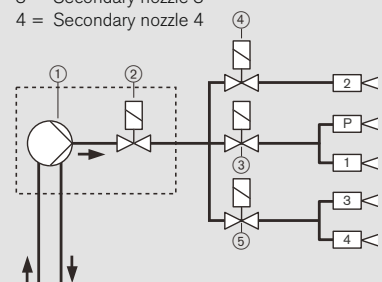

- ① Burner-mounted oil pump
- ② Oil pump solenoid valve
- ③ Ignition load solenoid valve (two-nozzle ignition)
- ④ Stage 1 solenoid valve
- ⑤ Stage 2 solenoid valve

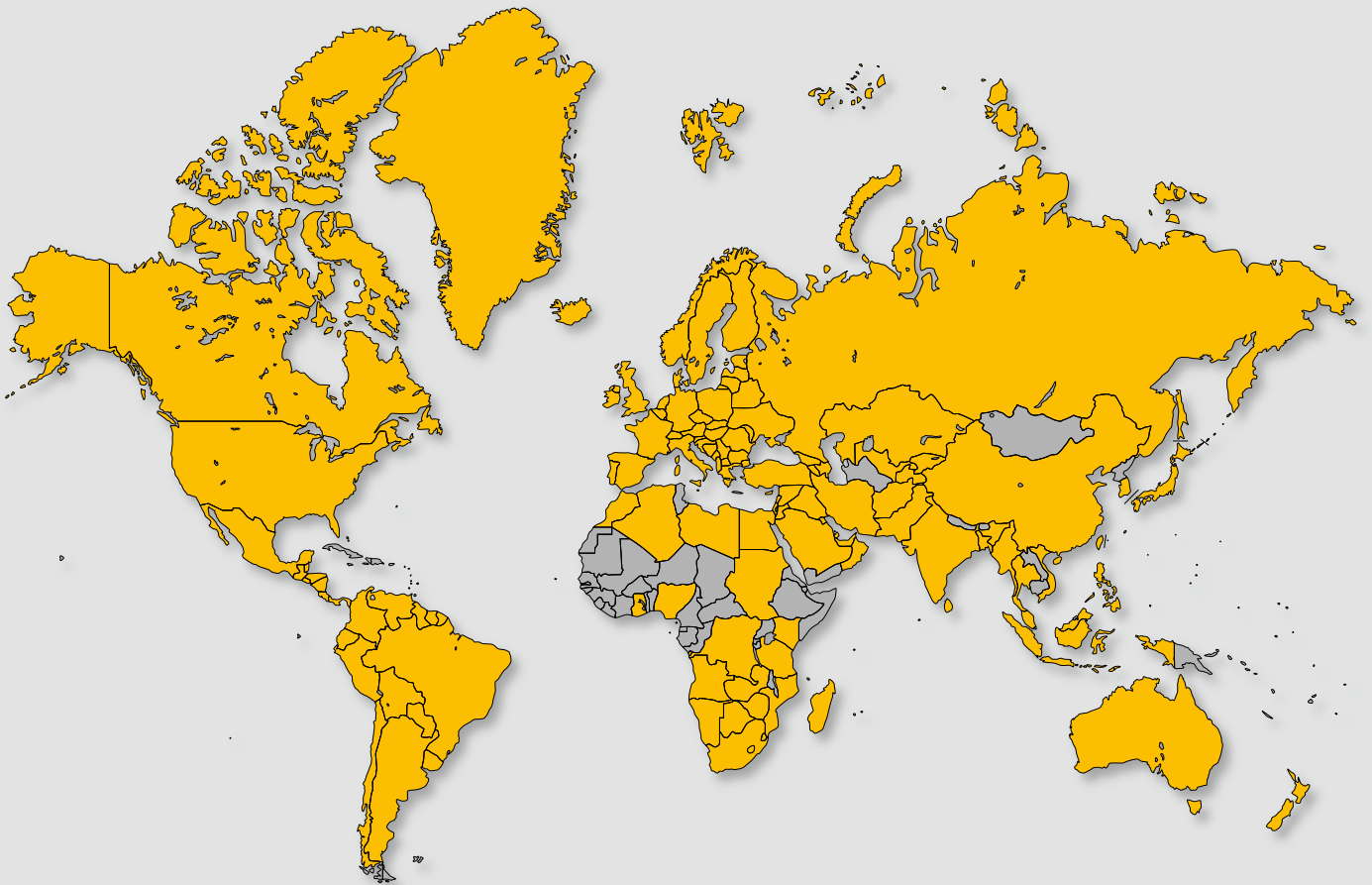

Weishaupt worldwide:

Afghanistan	Bulgaria	France	Japan	Malta	Pakistan	Slovenia	UAE
Algeria	Canada	Germany	Jordan	Mauritius	Panama	South Africa	Ukraine
Angola	Chile	Ghana	Kazakhstan	Mexico	Paraguay	South Korea	United Kingdom
Argentina	China	Greece	Kenya	Moldova	Peru	Spain	Uruguay
Australia	Colombia	Greenland	Kuwait	Monaco	Philippines	Sri Lanka	USA
Austria	Costa Rica	Guatemala	Kyrgyzstan	Montenegro	Poland	Sudan	Uzbekistan
Bahrain	Croatia	Guyana	Latvia	Morocco	Portugal	Suriname	Vatican City
Bangladesh	Cyprus	Honduras	Lebanon	Mozambique	Qatar	Swaziland	Venezuela
Belarus	Czech Republic	Hungary	Libya	Myanmar	Rep. of Congo	Sweden	Vietnam
Belgium	Denmark	India	Liechtenstein	Namibia	Romania	Switzerland	Zambia
Belize	Ecuador	Indonesia	Lithuania	Netherlands	Russia	Syria	Zimbabwe
Bolivia	Egypt	Iran	Luxembourg	New Zealand	San Marino	Taiwan	
Bosnia-	El Salvador	Iraq	Macedonia	Nicaragua	Saudi Arabia	Tajikistan	
Herzegovina	Estonia	Ireland	Madagascar	Nigeria	Serbia	Tanzania	
Botswana	Faroe Islands	Israel	Malaysia	Norway	Singapore	Thailand	
Brazil	Finland	Italy		Oman	Slovakia	Turkey	