

–weishaupt–

product

Information on duobloc industrial burners



WK-series industrial burners

WK40 to WK80 industrial burners • 300–32 000 kW



WK40 (up to 3 MW)



WK50 (up to 6 MW)



WK70 (up to 13 MW)

60 years of reliability

For more than six decades, Weishaupt burners have proven themselves on a wide variety of heat generators and process plant. Their success stems from Weishaupt's relentless demand for high-quality materials and workmanship, and from uncompromising quality control standards.

Weishaupt continually establishes new benchmarks with its well-engineered products, facilitated by the ever-constant efforts of its own in-house Research and Development Centre.

Weishaupt WK-series burners have been designed especially for industrial use. The modular design of the burners and their very large capacity range – 300 to 32 000 kW – means they are ideally suited to a broad spectrum of special applications.

All Weishaupt burners are manufactured at the company's main plant in Schwendi in southwestern Germany. Not only does this extremely modern production facility serve as a beacon of safety, precision, and cleanliness, it also allows for a rapid response when assembling small, medium and large-sized burners.

Experienced employees and the high proportion of in-house production allow Weishaupt to meet its own demands for the highest levels of quality.

High quality is reflected by Weishaupt's ISO 9001-2015 certification, which covers the development, production, sale, and servicing of burners and control panels.

Weishaupt offers individualised solutions for the supply of fuel and the control of burners and boilers. Of course, its product range also runs the gamut of modern instrumentation and control equipment, including fully comprehensive solutions for complex building automation projects.

Future-oriented, economical, flexible.



WK80 (up to 32 MW)

The powerful duobloc burner: Modular design for ratings up to 32 MW

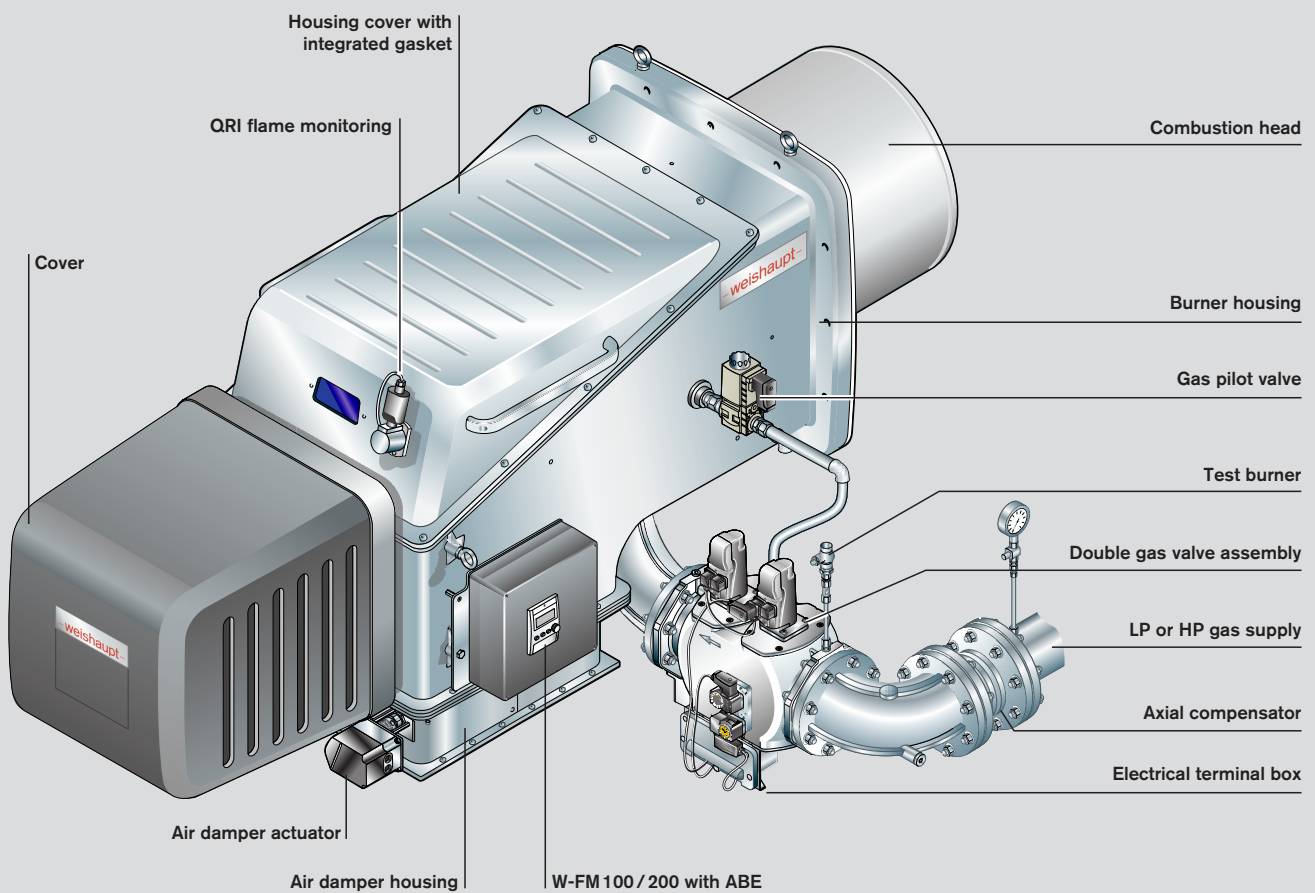

WK-series burners can be matched to a wide variety of applications – even under the hardest of conditions

Modular principle

Weishaupt WK-series industrial burners are of modular design. That means the fan, pump station, and preheater station are all selected independently of the burner. This concept offers a high degree of flexibility in matching to the most diverse applications.

Insulated burner housing

The burner housing is fitted with internal insulation (optional extra on the ambient-air versions of the WK 40 and 50), which reduces the surface temperature of the housing. The insulation also provides effective noise reduction.

Heat recovery with the use of preheated combustion air

Many industrial processes create high flue gas temperatures due to the high temperature of the medium used. A heat exchanger in the flue can be used to reclaim a large amount of energy from these hot flue gases. Weishaupt WK-series burners can be operated with combustion air temperatures of up to 250 °C, which increases efficiency by up to 10 %.

Accessibility

The controls assembly on a WK-series burner is generously dimensioned. The components and fuel lines are clearly laid out, ensuring excellent accessibility for maintenance work. A cover, which can be rotated by 90°, provides optimal ventilation and cooling of an HFO-firing burner's components.

Maintenance-friendly

The higher-capacity burners have an integrated rail system and servicing position that makes it very much easier to insert and remove the mixing assembly.

Nozzle lance and regulating sleeve

WK80 burners have a nozzle lance and regulating sleeve whose positions are adjusted by an actuator in response to the current firing rate. This ensures optimal flame stability and mixing energy throughout the entire turndown range.

Nozzle head shutoff device

At burner shutdown, or when changing over from oil to gas operation, safety shutoff devices in the nozzle head shut off the oil flow directly in the nozzle orifice, preventing the escape of any oil.

Ignition load

The W-FM combustion manager has parameters that allow for a special setting of the ignition load position. This makes reliable ignition possible under the most varied of conditions.

Controlled shutdown from partial load

Controlled shutdown of the burner always takes place from the partial-load position, thus preventing impact on the gas main or in the combustion chamber.

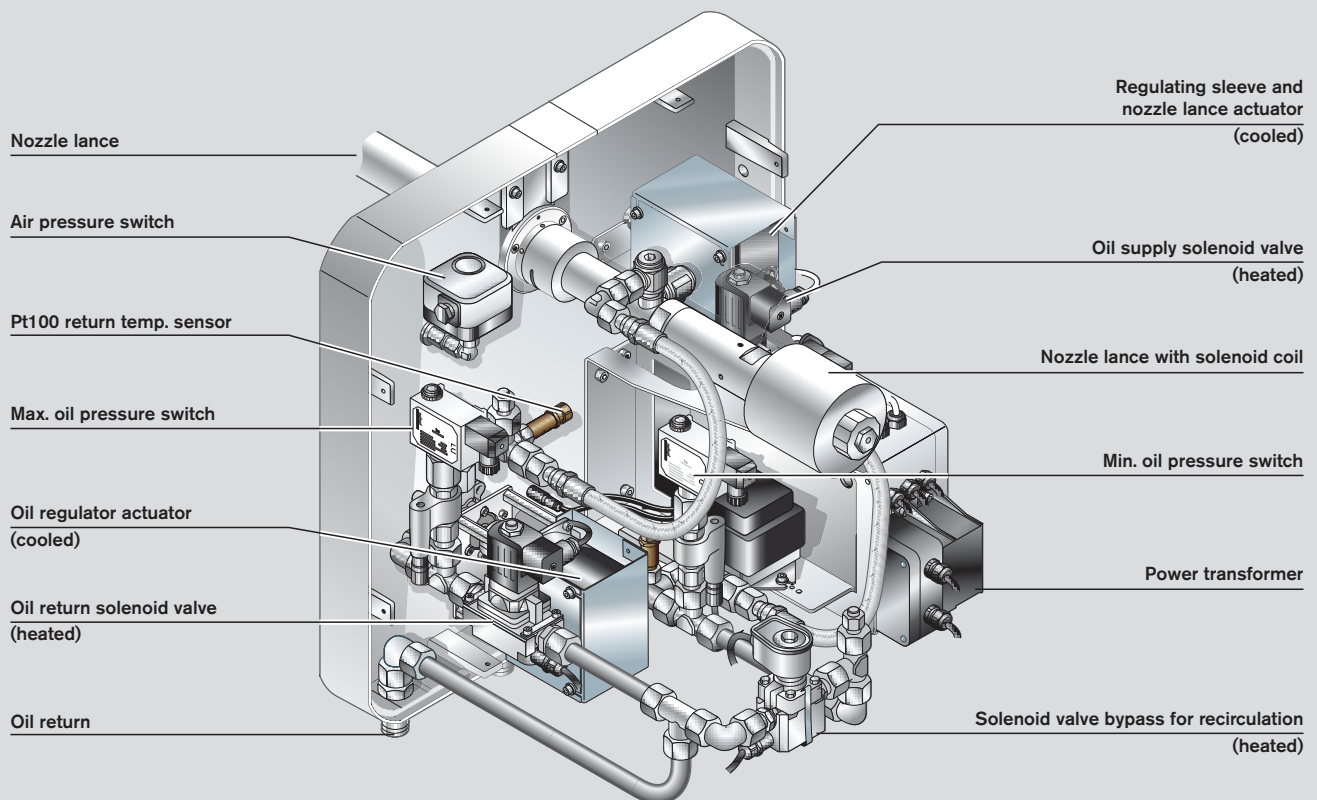

Controls assembly for a heavy-oil burner

Digital combustion management: Precise, simple, and reliable



Setting via the ABE control and display unit

Digital combustion management means optimal combustion figures, continuously reproducible setpoints, and ease of use.

All Weishaupt WK-series burners are equipped with digital combustion management and electronic compound regulation as standard. Modern combustion technologies demand the precise and continually reproducible dosing of fuel and combustion air. This optimises combustion efficiency and saves fuel.

Simple operation

Setting and control of the burner is achieved using a control and display unit. This is linked to the combustion manager via a bus system, enabling the user-friendly setting of the burner. The control and display unit has a clear text display with a choice of languages. An English/Chinese dual-screen version is available as an option should a Chinese-character display be desired.

Measures for saving energy and increasing safety and reliability

Variable speed drive provides multiple benefits. It facilitates a soft start of the burner fan, keeping the start current to a minimum. Fan speed is matched to the combustion air volume during operation, which saves electrical energy and reduces noise emissions.

O₂ trim saves fuel through a continual and extremely efficient optimisation of the combustion air. Control is effected by a system with a Lambda probe, which continually measures the oxygen content of the flue gas.

CO monitoring executes a safety shutdown of the burner if a predefined CO limit is exceeded, thereby ensuring the very highest degree of safety.

Combined CO control / O₂ trim ensures an ultimate degree of safety. CO emissions are continually monitored and, if the defined limit is exceeded, the burner is operated with an increased amount of excess air for a short period of time before the O₂ trim returns the burner to its preset O₂ setpoint. Should external influences prevent a non-critical condition from being reached, then the burner will undergo a controlled shutdown.

Features – digital combustion management	W-FM 100	W-FM 200
Single-fuel operation	●	●
Dual-fuel operation	●	●
Continuous firing >24 h	●	●
Variable speed drive available	–	●
O ₂ trim available	–	●
CO monitoring	–	○
Combined O ₂ trim and CO control	–	○
Temperature-compensated flue gas recirculation	–	○
LPG ignition unit control (WKMS40–70)	●	●
LPG ignition burner control (WK(G)MS80)	–	●
Gas oil ignition burner control (WKMS80)	●	●
ION/QRI/QRA 73 flame sensor for continuous firing	●	●
W-FC 4.0 flame monitoring	●	●
W-FC 5.0 flame monitoring	–	●
Maximum number of actuators	4	6
Gas valve proving	●	●
Integrated PID controller with automatic adaption. Pt/Ni temperature sensor, 0/2–10 V, and 0/4–20 mA inputs for temperature/pressure	○	●
0/2–10 V and 0/4–20 mA setpoint input for temperature/pressure	○	●
Configurable 0/4–20 mA analogue output	○	●
ABE control unit with 20 available languages (any one ABE limited to 6)	●	●
Dual-language / script ABE control unit (Chinese / English)	○	○
Removable ABE control unit (max. length of connecting bus line)	< 100 m	< 100 m
Fuel consumption meter (switchable)	–	●
Combustion efficiency display	–	●
eBUS/Modbus RTU interface	●	●
PC-supported commissioning	●	●

● Standard
○ Optional

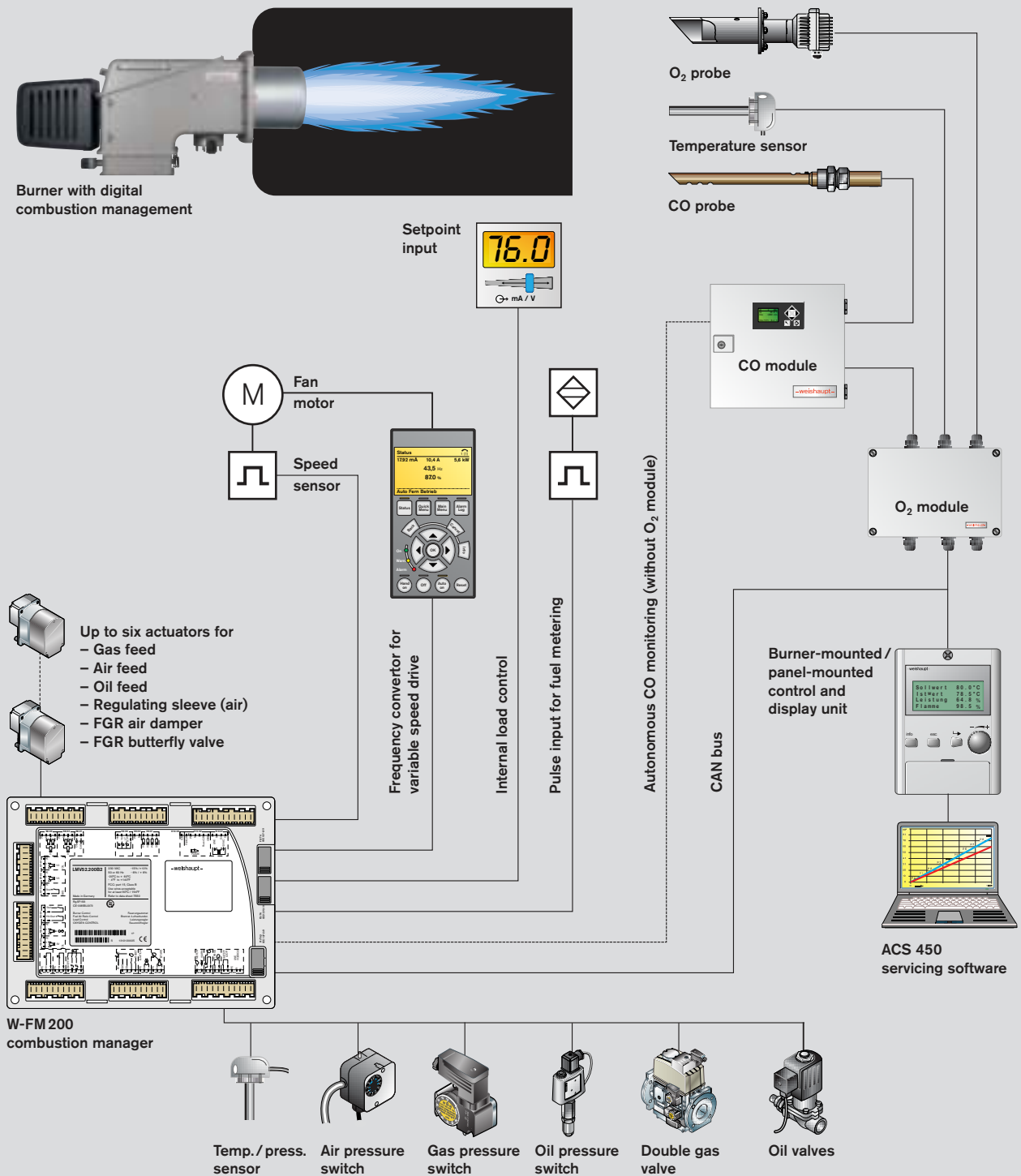

Limitless communications: flexible, reliable and simple

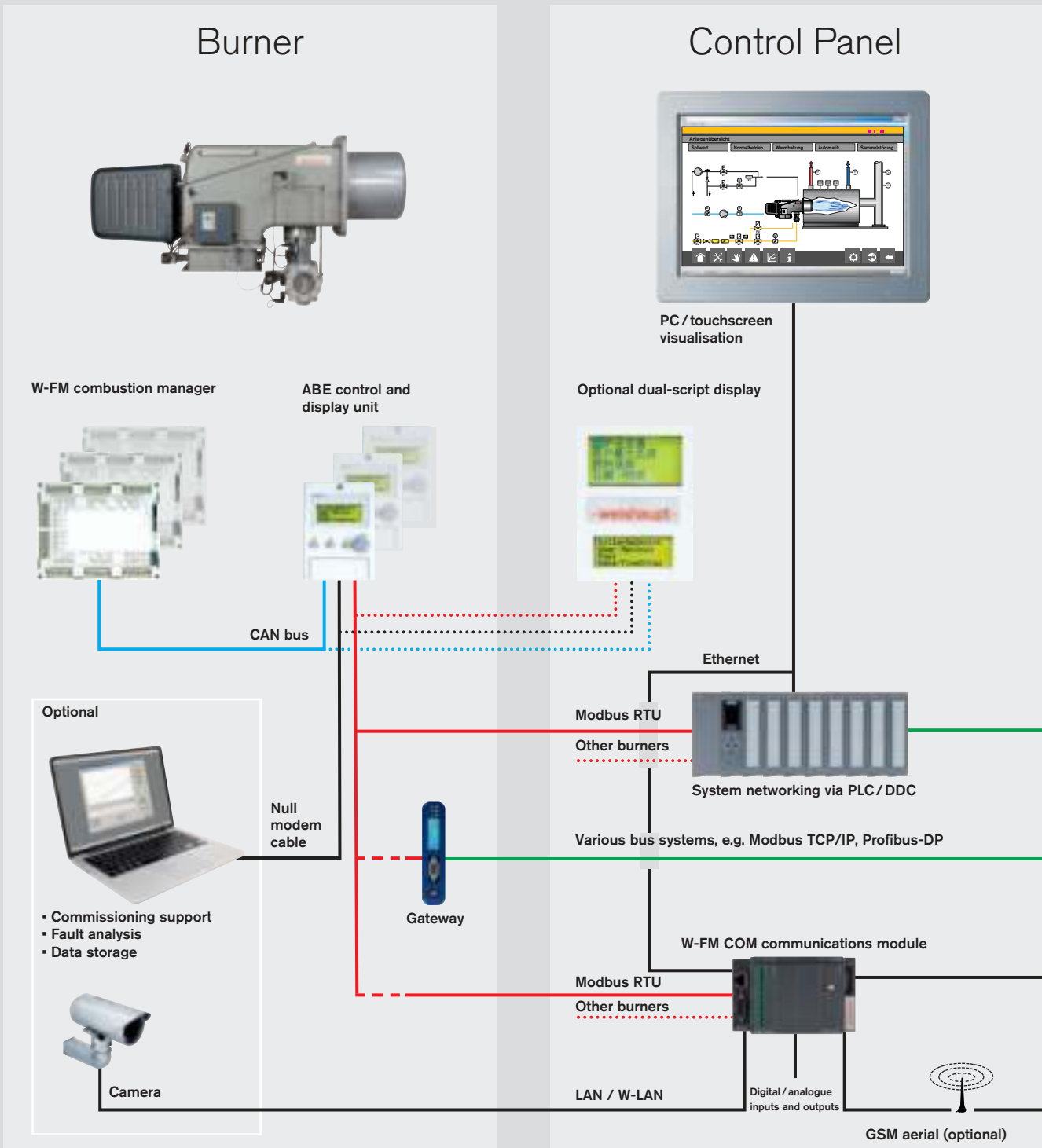

BMS



SCADA
Supervisory Control
and Data Acquisition

Various bus systems

Various bus systems

GSM / web server

Worldwide



Laptop / tablet



Smartphone

Email
SMS

- Monitoring and alarms
- Read process and meter values
- Adjust setpoints
- Read fault and lockout history
- Controllable digital inputs and outputs











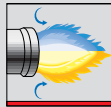

The right mixing assembly for every application

Mixing assembly type	Flame geometry		Burner type	Load-dependent air regulation in the M.A. ³⁾	Fuels				NO _x Class ¹⁾			
	Length	Diameter			Natural gas	LPG	Gas oil	Heavy oil	Natural gas	LPG	Oil (gas oil)	
<p>Maintenance-friendly construction: On all burner versions, the standard-length combustion head (i.e. the flame tube and mixing assembly) can be inserted and withdrawn through the service opening in the burner housing. To further assist removal, the mixing assemblies on WK80 burners are guided by rail.</p>												
<p>ZM(H) Mixing assembly for gas, oil, and dual-fuel burners. For plant with no particular NO_x requirements.</p> <p>ZM(H)-NR Mixing assembly for gas and dual-fuel burners. Gas-side NO_x reduction compared to ZM version.</p>			WK 40 WK 50/1 WK 50/2 WK 70/1 WK 70/3 WK 80/3 WK 50/1 WK 50/2 WK 70/1 WK 70/3 WK 80/3	✓ ✓ ✓ ✓ ✓ ✓ ✓ ✓ ✓ ✓ ✓	○ - - - - - ○ ● ● ● ●	○ - - - - - ○ ● ● ● ●	○ ○ ○ ● ○ ○ ○ ○ ○ ○ ○	○ ○ ○ ○ ○ ○ ○ ○ ○ ○ ○	- - - - - - - 3 2 2 3 3	- - - - - - - - 3 3 3	- - - 1 1 1 - 2 2 1 1	
<p>ZM(H)-LN Low-NO_x mixing assembly for gas burners. Further reduction in NO_x emissions compared to 1LN-version burners.</p>			WK 40 WK 70	- -	○ ●	- -	- -	- 3	- -	- -	- -	
<p>ZM(H)-1LN Low-NO_x mixing assembly for gas and dual-fuel burners. For plant with gas and oil-side NO_x requirements.</p>			WK 50/1 WK 50/2 WK 70	- - -	○ ○ ●	○ ○ ●	- - -	- - 3	- - 3	- - 3	- - 2	
<p>ZM(H)-3LN Low-NO_x mixing assembly for gas, oil, and dual-fuel burners. For plant with low gas and oil-side NO_x requirements.</p>			WK 40 WK 50/1 WK 50/2 WK 70 WK 80/1 WK 80/2	✓ ✓ ✓ ✓ ✓ ✓	○ ○ ○ ● ● ○	○ ○ ○ ● ● ○	- - - - - -	- - - 3 3 -	- - - 3 3 -	- - - 3 3 -	- - - 3 3 -	

¹⁾ Combustion-air temperatures < 40 °C

²⁾ Minimum requirements for the combustion chamber geometry must be agreed with Weishaupt's headquarters

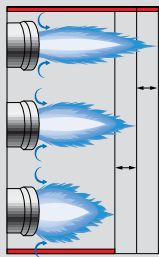
³⁾ M.A. = mixing assembly

Mixing assembly type	Flame geometry		Burner type	Load-dependent air regulation in the M.A. ³⁾	Fuels				NO _x Class ¹⁾		
	Length	Diameter			Natural gas	LPG	Gas oil	Heavy oil	EN 676	LPG	Oil (gas oil)
<p>ZM(H)-4LN Low-NO_x mixing assembly for gas burners equipped with flue gas recirculation.</p> <p>For plant with extremely low NO_x limits. Lowest NO_x emissions in comparison with all other versions.</p> 			WK 70/1 WK 70/2 WK 80/1 WK 80/2	✓ ✓ ✓ ✓	● ● ● ●	- - - -	- - - -	3 3 3 3	- - - -	- - - -	
<p>ZM(H) - 1SF Swirl-flame mixing assembly for gas, oil, and dual-fuel burners.</p> <p>Swirl-flame mixing assembly for extremely short combustion chambers in water tube boilers.</p> 			WK 50/2 WK 70/1 WK 80/3	✓ ✓ ✓	○ ○ ○	- - -	○ ○ ○	- - -	- - -	- - -	
<p>ZM(H) - 3SF Swirl-flame mixing assembly for longer combustion chambers. Flame length is comparable to the NR version.</p> 			WK 80/6	✓	○	- - -	- - -	- - -	- - -	- - -	
<p>ZM(H) - VSF Swirl-flame mixing assembly for gas burners.</p> <p>Swirl-flame mixing assembly for extremely short combustion chambers and for elongated, D-type combustion chambers with low cross-sectional loads. Internal fittings (circular blanks) can be used to optimise flame geometry.²⁾</p> 			WK 80/4 WK 80/5	✓ ✓	● ●	● -	- -	3 2	3 -	- -	

● With type approval ○ Without type approval ● Type approval planned

EN emission classes

Fuel	Natural Gas (EN 676)			LPG (EN 676)			Gas Oil (EN 267)		
	1	2	3	1	2	3	1	2	3
NO _x emissions in mg/kWh	≤ 170	≤ 120	≤ 80	≤ 230	≤ 180	≤ 140	≤ 250	≤ 185	≤ 120

Use

Fuels

Natural gas
LPG

Class D gas oil per BS 2869 / IS 251
Class A2 gas oil per BS 2869 / IS 251
10 % biodiesel blends (B10)
MFO / HFO (< 50 mm²/s at 100 °C)

The suitability of fuels of differing quality must be confirmed in advance with Weishaupt.

Applications

Weishaupt WK-series burners are suitable for intermittent and continuous firing on:

- LTHW boilers
- HTHW boilers
- Steam boilers
- Air heaters
- Thermal fluid heaters
- Certain process applications

Installation positions

When installed horizontally, the burner can be mounted on the heat generator in 90° rotational increments (combustion air inlet from above, below, or either side). The burner can also be installed vertically, to fire either upwards or downwards. (See the planning and installation handbook for details and exceptions, print No. 83112402)

Permissible ambient conditions

- Ambient temperature
-15 to + 40 °C for gas firing
-10 to + 40 °C for oil firing
- Combustion air temperature up to 250 °C for ZMH-version burners
- Maximum 80 % relative humidity, no condensation
- The combustion air must be free of aggressive substances (halogens, chlorides, fluorides etc.) and impurities (dust, debris, vapours, etc.)
- Adequate ventilation is required for operation in enclosed spaces
- For plant in unheated areas, certain further measures may be required

Use of the burner for other applications or in ambient conditions not detailed above is not permitted without the prior written agreement of Max Weishaupt GmbH. Burner service intervals will be reduced to accord with the more extreme operational conditions.

Protection Class

IP 54

Standards compliance

The burners are tested by an independent body and fulfil the applicable requirements of the following European Union directives and applied standards:

EMC

EMC Directive
2014/30/EU

Applied standards

- EN 61000-6-1 : 2007
- EN 61000-6-2 : 2005
- EN 61000-6-4 : 2007

LVD

Low-Voltage Directive
2014/35/EU

Applied standards

- EN 60335-1 : 2010
- EN 60335-2-102 : 2010

MD

Machinery Directive
2006/42/EC

Applied standards

- EN 267 Annex J,
- EN 676 Annex J,

GAR

Gas Appliances Regulation
2016/426/EU

Applied standards

- EN 676 : 2008

PED¹⁾

Pressure Equipment Directive
2014/68/EU

Applied standards

- EN 267 Annex K,
- EN 676 Annex K,
- Conformity assessment procedure: Module B

¹⁾ With the selection of appropriate equipment.

The burners are labelled with

- CE Mark
- CE-PIN per 2009/142/EC
- Identification No. of the notified body

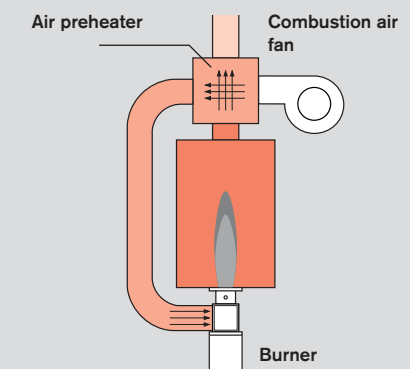
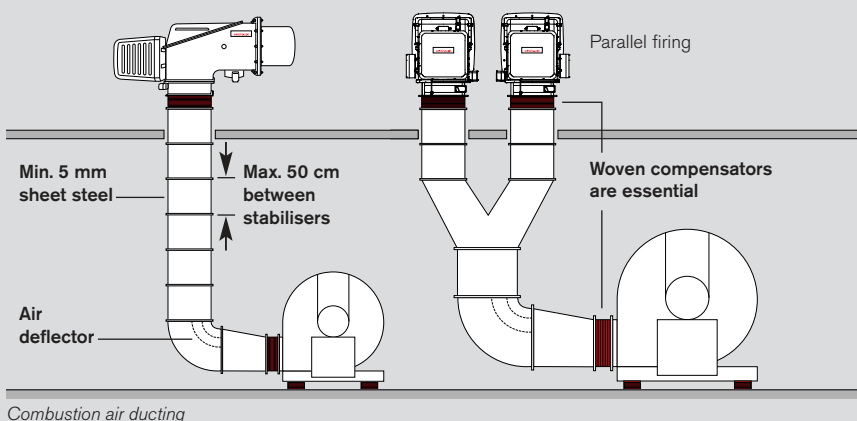

Model designation

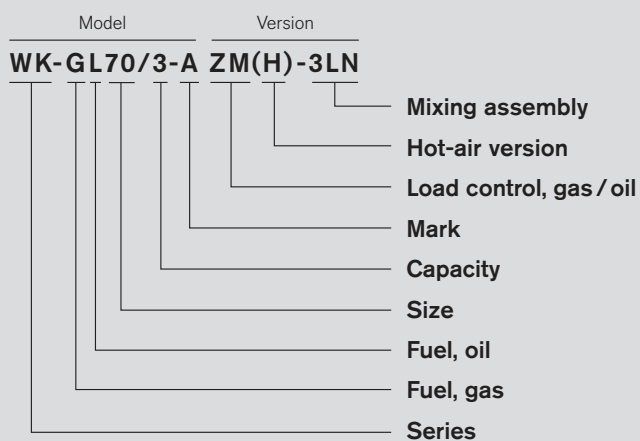

Details	Code	Meaning	Associated fuel
Series	WK	Weishaupt duobloc burner	
Fuel	G L, MS	Gas (Natural gas, LPG, ...) Oil (Gas oil, HFO, ...)	
Load control	ZM	Sliding-two-stage/ modulating	Gas / oil Gas / oil
Mixing assembly	- NR LN 1LN 3LN 4LN 1SF 3SF VSF	Standard NO _x -reduced gas firing Low NO _x Low NO _x Multiflam® Ultra-low NO _x with FGR Swirlflame Swirlflame Variable swirlflame	Gas / oil Gas / oil Gas Gas / oil Gas / oil Gas Gas / oil Gas Gas
Suffix	H	Hot-air version	Gas / oil

Overview of burner regulation

Gas and oil-fired operation

Weishaupt WK-series burners can have sliding-two-stage or modulating operation when firing gas or oil, depending on the method of load control employed.

Sliding-two-stage regulation (ZM, R)

- Two-term switching (e.g. temperature or pressure stat) causes actuators to drive the burner to partial load or full load in response to heat demand.

Combustion remains CO and smoke-free between load points.

Modulating regulation (ZM, R)

- An electronic load controller causes actuators to make infinitely variable load adjustments in response to heat demand.
- Modulating operation:
 - W-FM 100 with an optional integral load controller
 - W-FM 200 with its standard integral load controller
- Alternatively, a PID controller can be fitted into the control panel.

Sliding-two-stage

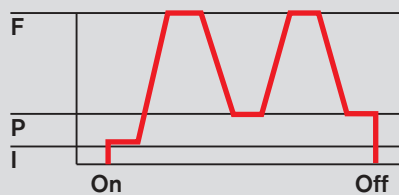

Modulating

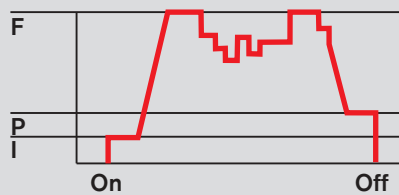

F = Full load (nominal load)
 P = Partial load (minimum load)
 Z = Ignition load

Control ¹⁾

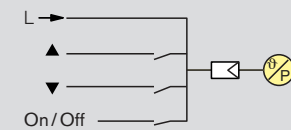
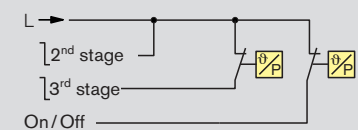

¹⁾ Alternatively, staged control can also be effected by an electronic PID controller. In this case, appropriate temperature sensors or pressure transducers will be required.

Maximum turndown

Oil burners

Burner	Version ¹⁾ ZM(H)	Gas oil	MFO/HFO
WK40–WK50	Standard	3:1	3:1
WK70–WK80	Standard	5:1	3.5:1
WK40–WK80	3LN	5:1	–
WK50–WK80	1SF	4:1	3:1

¹⁾ Not every mixing assembly version is available for each burner size.

Gas burners

Burner	Version ¹⁾ ZM(H)	Natural gas	LPG ²⁾
WK40	Standard	4:1	4:1
WK40–WK70	NR/LN/1LN/3LN/4LN	8:1	6:1
WK50–WK70	1SF	8:1	6:1
WK80	3LN/4LN/VSF/3SF	8:1	6:1

¹⁾ Not every mixing assembly version is available for each burner size.

²⁾ Not every mixing assembly version is suitable for LPG.

Dual-fuel burners

Burner	Version ¹⁾ ZM(H)	Natural gas	LPG ²⁾	Gas oil	MFO/HFO ³⁾
WK40–WK50	Standard/NR/3LN	4:1	4:1	3:1	3:1
WK70–WK80	Standard/NR/1LN/3LN	8:1	6:1	5:1	3.5:1
WK70–WK80	1SF	8:1	6:1	4:1	3:1

¹⁾ Not every mixing assembly version is available for each burner size. ²⁾ Not every mixing assembly version is suitable for LPG. ³⁾ Not with multiflam® 3LN burners.

Constraints:

Without excess air limitations. Combustion values not guaranteed through the entire turndown range. All operational points must lie within the burner's capacity chart. Higher turndowns may be achievable in certain cases (subject to agreement with Weishaupt's headquarters).

Overview of capacities

Oil burners

Standard version

WKL and WKMS gas oil and MFO/HFO burners

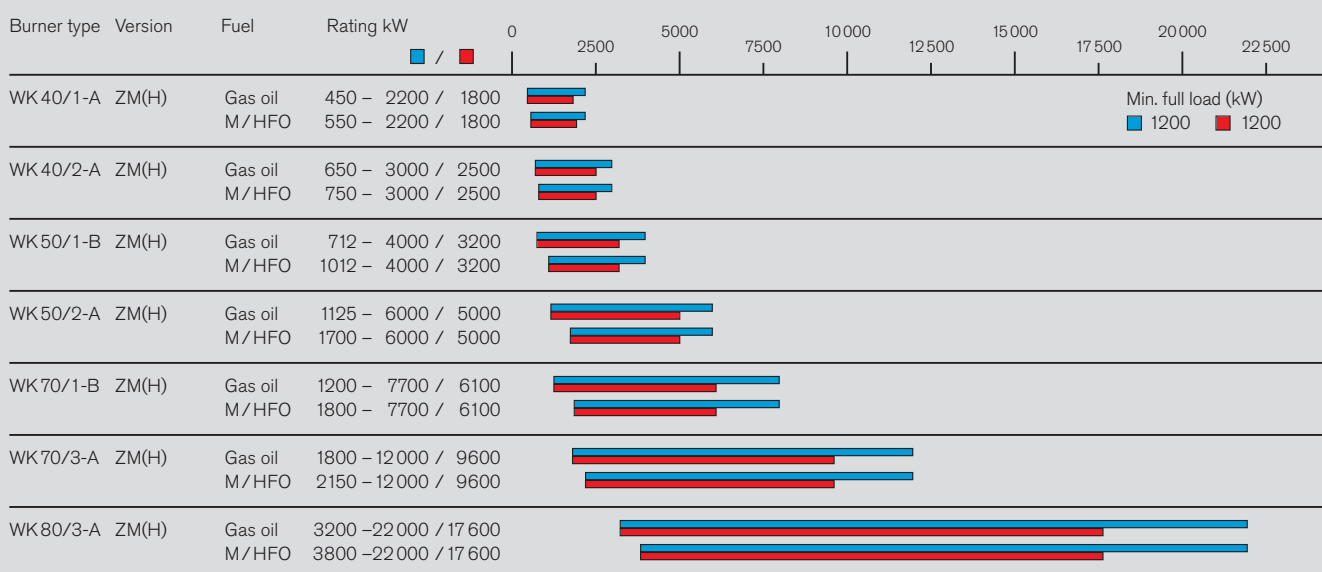

3LN multiflam® version

WKL gas oil burners (WKGL-based)

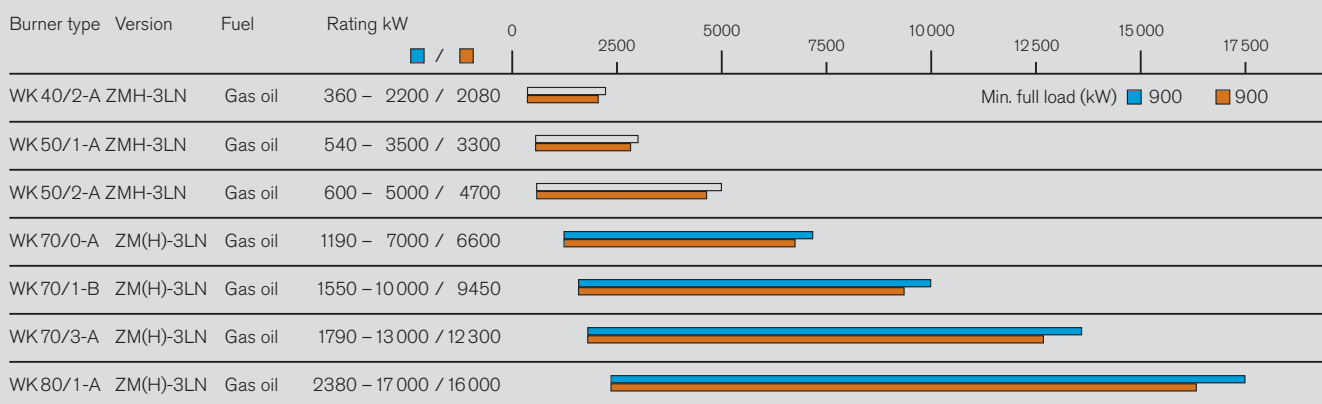

1SF version

WKL and WKMS gas oil and MFO/HFO burners

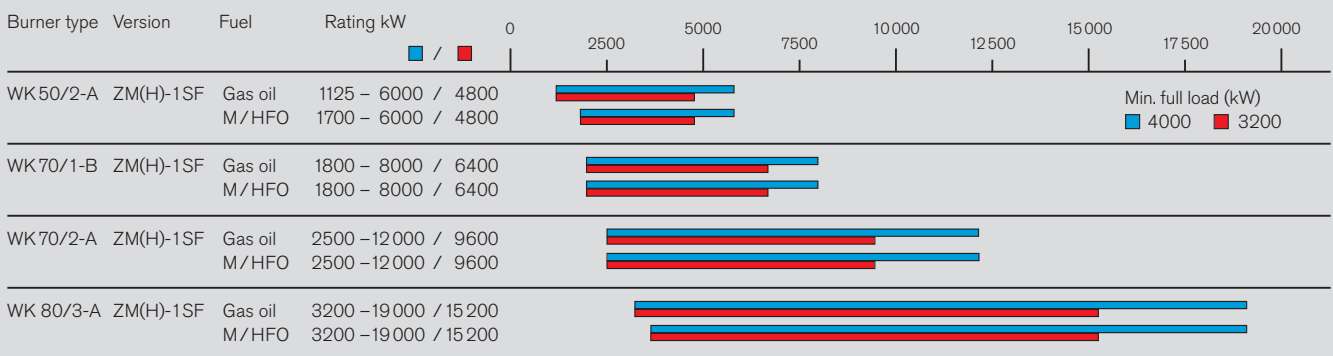

Burner-selection criteria:

The minimum full-load rating within a burner's capacity range corresponds to the maximum rating of the next-smallest size of the same version burner. Please refer to the planning and installation handbook for fan selection and arrangement, gas valve trains, special equipment, technical data, and dimensions.

- Ambient combustion air with temperatures up to 40 °C
- Ambient combustion air with temperatures up to 40 °C
- Preheated combustion air with temperatures up to 250 °C
- Preheated combustion air with temperatures up to 100 °C

Burner ratings can be interpolated linearly for combustion air temperatures between 40 °C and 100 °C / 250 °C.

Overview of capacities

Gas burners

Standard version

WKG natural gas and LPG burners

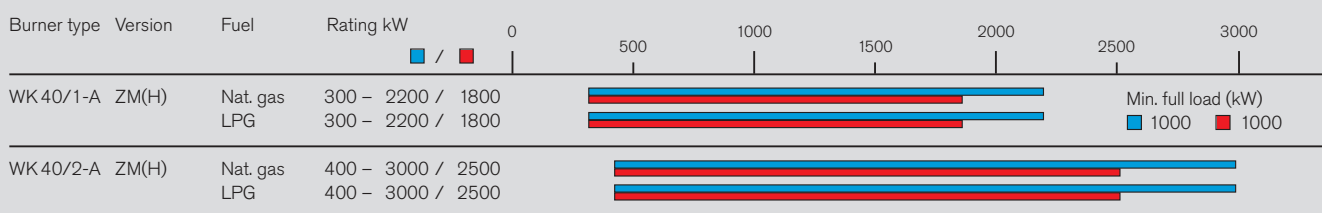

NR version

WKG natural gas and LPG burners

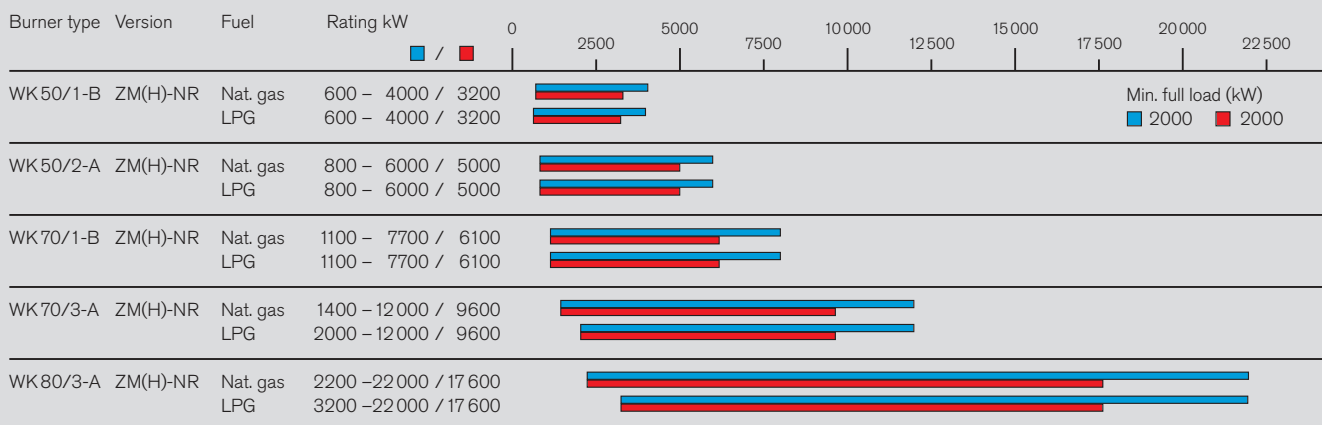

LN version

WKG natural gas burners

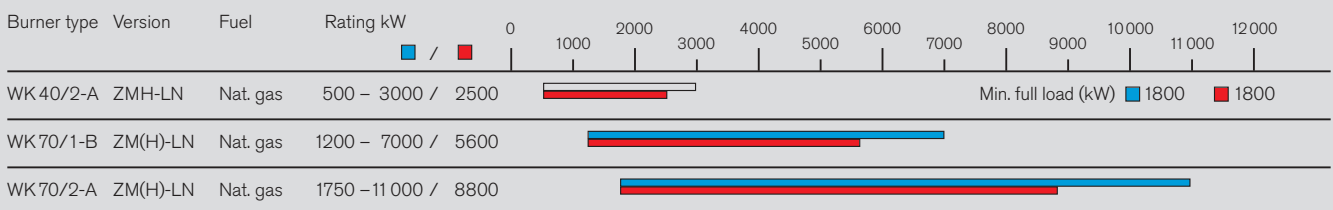

1LN version

WKG natural gas and LPG burners

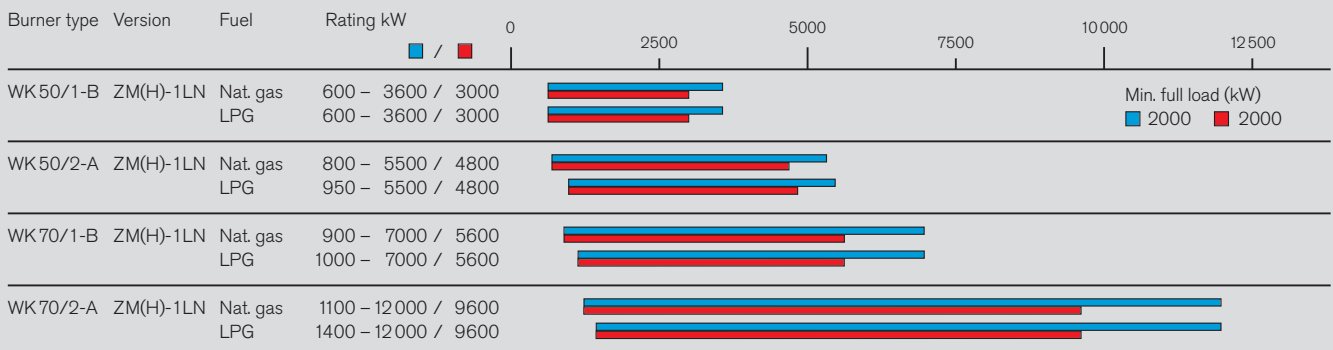

Burner-selection criteria:

The minimum full-load rating within a burner's capacity range corresponds to the maximum rating of the next-smallest size of the same version burner. Please refer to the planning and installation handbook for fan selection and arrangement, gas valve trains, special equipment, technical data, and dimensions.

- Ambient combustion air with temperatures up to 40 °C
- Ambient combustion air with temperatures up to 40 °C
- Preheated combustion air with temperatures up to 250 °C

Burner ratings can be interpolated linearly for combustion air temperatures between 40 °C and 250 °C.

Overview of capacities

Gas burners

3LN multiflam® version

WKG natural gas and LPG burners

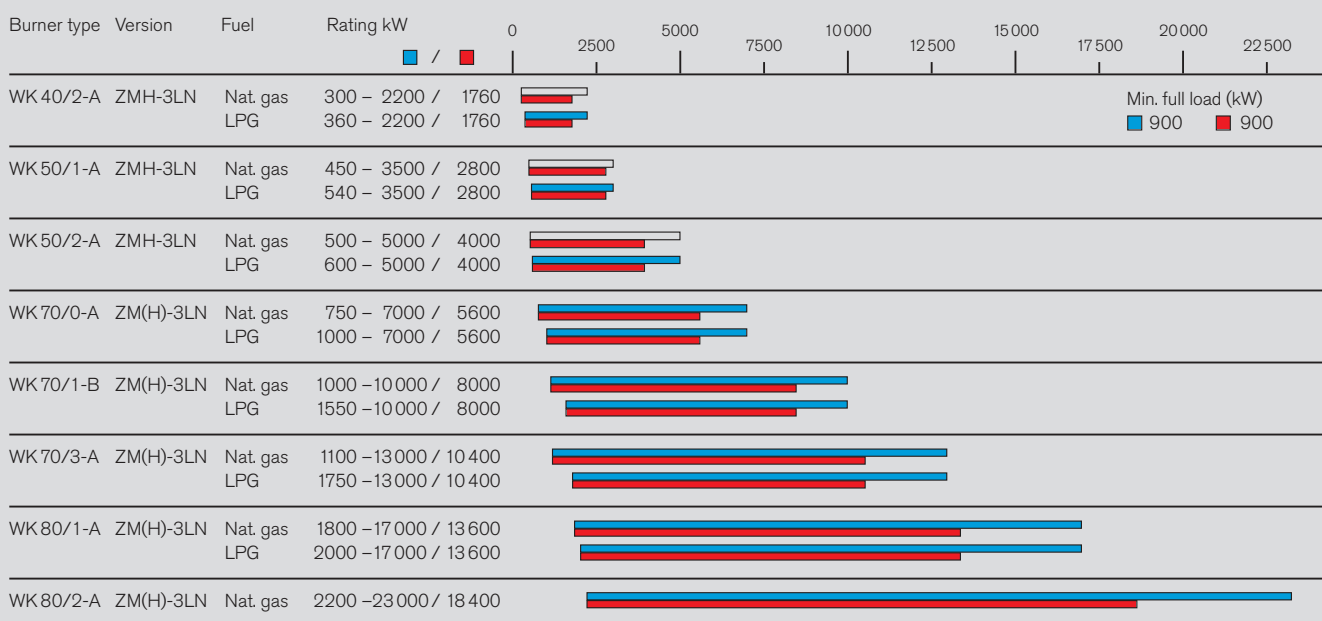

4LN version (flue gas recirculation)

WKG natural gas and LPG burners

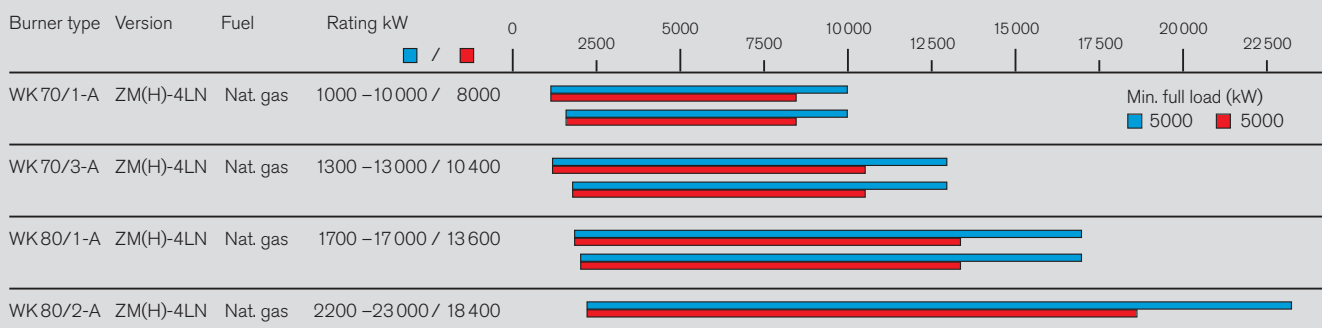

1SF version

WKG natural gas burners

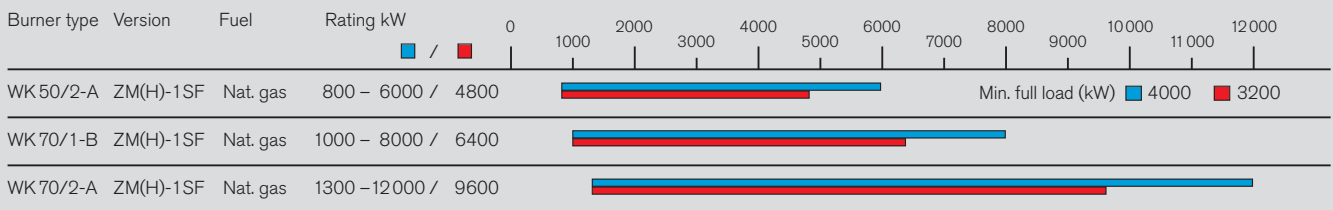

3SF version

WKG natural gas burners

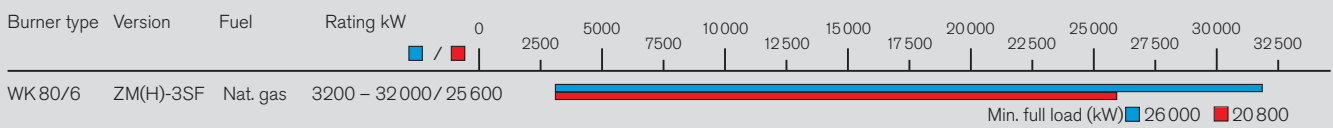

VSF version

WKG natural gas and LPG burners

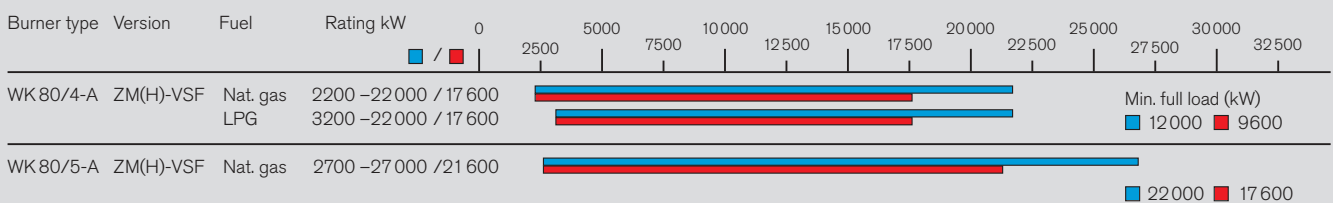

Burner-selection criteria:

The minimum full-load rating within a burner's capacity range corresponds to the maximum rating of the next-smallest size of the same version burner. Please refer to the planning and installation handbook for fan selection and arrangement, gas valve trains, special equipment, technical data, and dimensions.

Note for 4LN burners:

The hot-air version (ZMH-4LN) must be used if the mixing temperature of the combustion air and flue gas is greater than 60 °C.

- Ambient combustion air with temperatures up to 40 °C
- Ambient combustion air with temperatures up to 40 °C
- Preheated combustion air with temperatures up to 250 °C

Burner ratings can be interpolated linearly for combustion air temperatures between 40 °C and 250 °C.

NR version

WKGL/WKGMS dual-fuel burners



Burner-selection criteria:

The minimum full-load rating within a burner's capacity range corresponds to the maximum rating of the next-smallest size of the same version burner. Please refer to the planning and installation handbook for fan selection and arrangement, gas valve trains, special equipment, technical data, and dimensions.

- Ambient combustion air with temperatures up to 40 °C
- Preheated combustion air with temperatures up to 250 °C

Burner ratings can be interpolated linearly for combustion air temperatures between 40 °C and 250 °C.

Overview of capacities

Dual-fuel burners

1LN version

WKGL dual-fuel burners

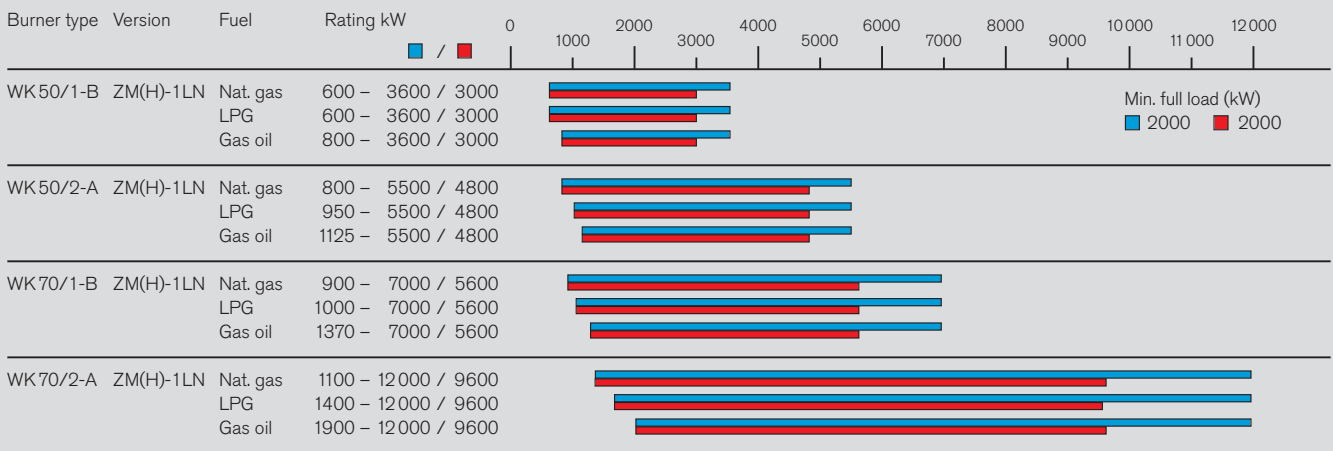

3LN multiflam® version

WKGL dual-fuel burners



1SF version

WKGL/WKGMS dual-fuel burners

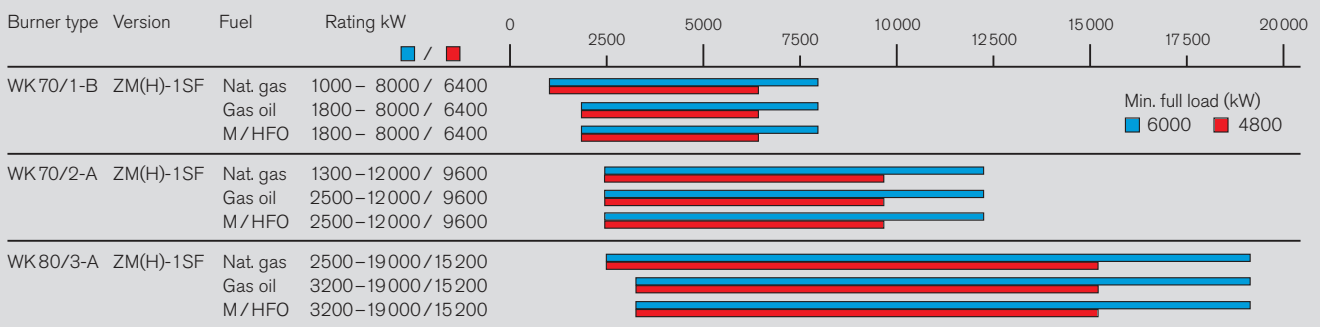

Burner-selection criteria:

The minimum full-load rating within a burner's capacity range corresponds to the maximum rating of the next-smallest size of the same version burner. Please refer to the planning and installation handbook for fan selection and arrangement, gas valve trains, special equipment, technical data, and dimensions.

- Ambient combustion air with temperatures up to 40 °C
- Ambient combustion air with temperatures up to 40 °C
- Preheated combustion air with temperatures up to 250 °C
- Preheated combustion air with temperatures up to 100 °C

Burner ratings can be interpolated linearly for combustion air temperatures between 40 °C and 100 °C / 250 °C.

Fuel systems

Gas and dual-fuel burners (gas side)

Limits						LP1	LP2	LP3	HP		
									Standard	So	SoH
Gas flow pressure into shutoff valve at max. burner load						≤ 300 ¹⁾ mbar	≤ 300 ¹⁾ mbar	300–500 mbar	300–10 000 ²⁾ mbar		
Regulated gas pressure p _o						≤ 200 mbar	≤ 250 mbar	≤ 360 mbar	≤ 210 mbar	> 210–350 mbar	350–500 mbar
Maximum operating pressure (MOP) of the gas supply						500 mbar	500 mbar	700 mbar	1000 / 5000 / 10 000 / 16 000 ³⁾ mbar		
Minimum MOP rating for components downstream of the gas pressure regulator						500	500 mbar	700 ⁴⁾ mbar	500 mbar	500 mbar	700 ⁴⁾ mbar
Nominal valve train size	Gas valve assembly type	Burner size				Low-pressure supply with FRS regulator	Low-pressure supply with SKP25 regulator on the VGD valve assembly	Low-pressure supply with SKP25 regulator on the VGD valve assembly	High-pressure supply with HP regulator		
		WK 40	WK 50	WK 70	WK 80						
1½"	W-MF 512	●				●			●		
2"	DMV 525/12	●	●			●			●		
DN 65	DMV 5065/12	●	●	●		●			●		
DN 80	DMV 5080/12	●	●	●		●			●		
DN 100	DMV 5100/12	●	●	●	●	●			●		
DN 125	VGD 40.125	●	●	●		●			●		
					●	●	●	● ⁴⁾	●	●	● ⁴⁾
DN 150	VGD 40.150		●	●		●			●		
					●	●	●	● ⁴⁾	●	●	● ⁴⁾

¹⁾ See page 23 for exceptions.

²⁾ Dependent on the MOP of the high-pressure gas regulator.

³⁾ Specific MOP depends on high-pressure gas regulator type.

⁴⁾ Requires the use of pressure switches and ignition gas valves rated for ≥ 700 mbar.

Valve train selection

Low-pressure (LP) gas supply details

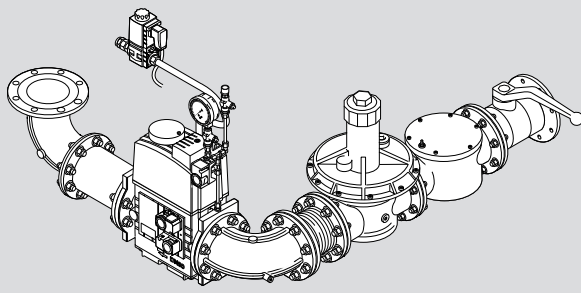
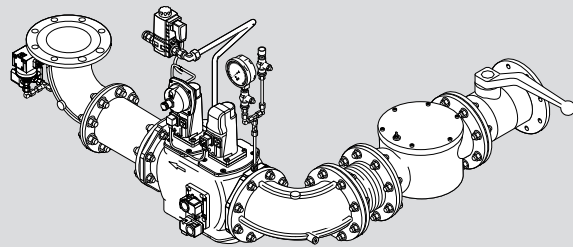
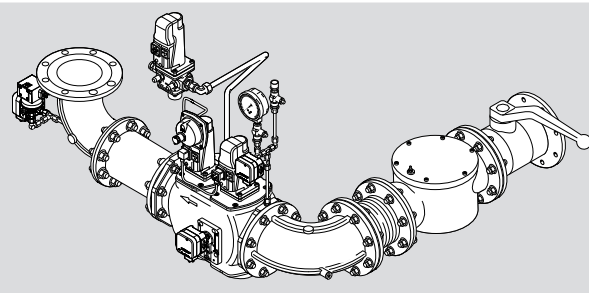
LP1	<p>Low-pressure gas supply with FRS regulator Used when:</p> <ul style="list-style-type: none"> – The gas flow pressure at maximum burner load is ≤ 300 mbar.¹⁾ – The regulated pressure p_o together with the combustion chamber resistance does not exceed 200 mbar. – The MOP ²⁾ does not exceed 500 mbar. 	
LP2	<p>Low-pressure gas supply with SKP25 regulator For VGD valve assemblies. Used when:</p> <ul style="list-style-type: none"> – The gas flow pressure at maximum burner load is ≤ 300 mbar.¹⁾ – The regulated pressure p_o together with the combustion chamber resistance does not exceed 250 mbar. – The MOP ²⁾ does not exceed 500 mbar. 	
LP3	<p>Low-pressure gas supply with SKP25 regulator For VGD valve assemblies. Used when:</p> <ul style="list-style-type: none"> – The gas flow pressure at maximum burner load is in the range of 300–500 mbar. – The regulated pressure p_o together with the combustion chamber resistance does not exceed 360 mbar. – The MOP ²⁾ does not exceed 700 mbar. 	

Layout of the valve train (vertical burner installation)

The "offset gas butterfly and valve assembly" option is very strongly recommended because of the increased heat radiation due to vertical boiler design and the high temperatures of media such as thermal fluid.

Support of the valve train

The gas valve train should be properly supported in accordance with the site conditions. See the Weishaupt accessories list for various valve train support components.

Compensator

To enable a tension-free mounting of the valve train, the fitting of a compensator is strongly recommended.

Gas meter

A gas meter must be installed to measure gas consumption during commissioning and servicing.

Optional thermal shutoff (when required by local regulations)

Integrated into the ball valve of screwed valve trains. A separate component with HTB seals fitted before the ball valve on flanged valve trains.

Safeguarding of the high-pressure gas supply in the event of a failure

The supplier must safeguard the gas flow pressure such that, in the event of failure, it cannot exceed the MOP ²⁾ of the burner's gas valve train.

¹⁾ Exceptions

Normally, valve train layouts LP1 and LP2 are used for gas flow pressures up to a maximum of 300 mbar. This allows for pressure losses between the transfer station and the valve train. Furthermore, it is assumed that the transfer station utilises components (SSV, SRV, regulator) that are not of the highest class of accuracy. In individual cases, following consideration and approval by Weishaupt's headquarters, a gas flow pressure of up to 360 mbar can be approved if the appropriate conditions exist.

²⁾ MOP = Maximum Operating Pressure

Fuel systems

Gas and dual-fuel burners (gas side)

LP1

Gas side, WKG(L) 40–80, WKGMS 40–70
versions ZM/NR/1LN/3LN/1SF/VSF

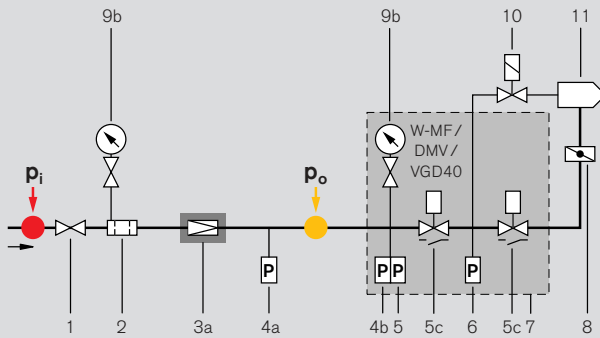

Gas side, WKG 40–70
version LN

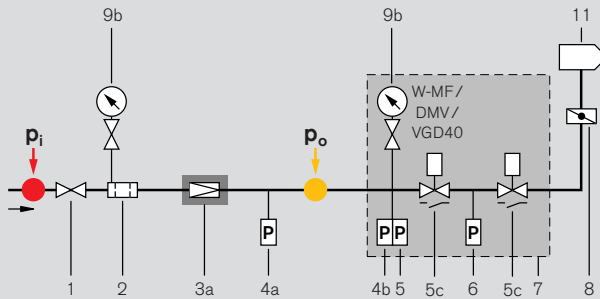

Gas side, WKGMS 80
versions ZM/NR/1SF

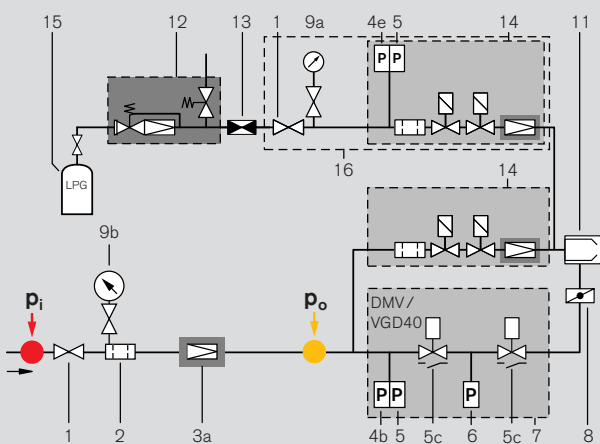

LP2

Gas side, WKG(L) 80
versions NR/3LN/1SF/VSF/3SF

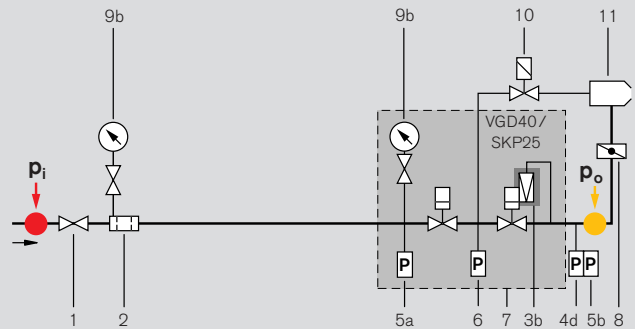

Gas side, WKGMS 80
versions NR/1SF

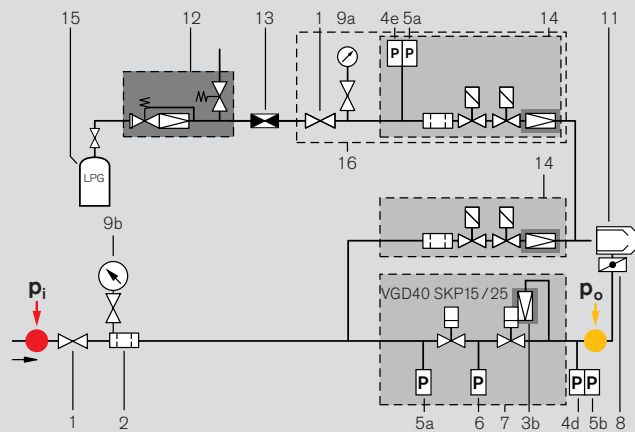

LP3

Gas side, WKG(L) 80
versions NR/3LN/1SF/VSF/3SF

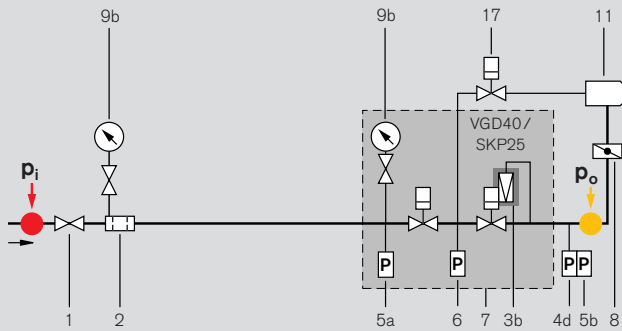





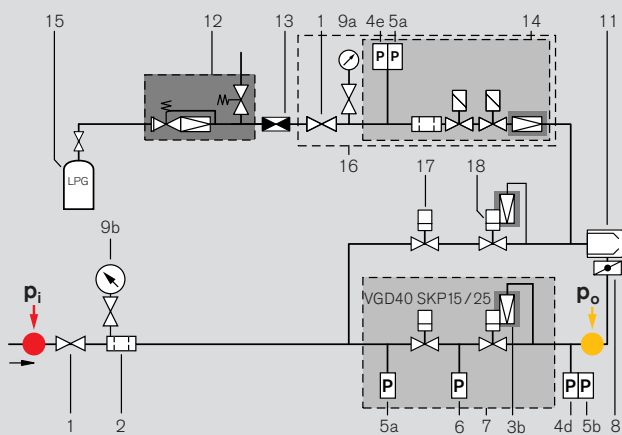

- 1 Ball valve
- 2 Gas filter
- 3a Low-pressure FRS regulator
- 3b Low-pressure SKP25 regulator
- 4a High gas pressure switch on screwed valve trains (mounted immediately after the regulator)
- 4b High gas pressure switch on flanged valve trains (mounted on the valve assembly inlet)
- 4d High gas pressure switch on flanged valve train (mounted on the elbow)
- 4e High gas pressure switch (mounted on the LPG ignition burner assembly)
- 5 Low gas pressure switch
- 5a Low gas pressure switch (mounted on the valve assembly inlet)
- 5b Additional low gas pressure switch in conjunction with VGD40 and SKP15 & 25 (mounted on the elbow)
- 5c "Open" position indicator switch in conjunction with VGD40 and 2x SKP15
- 6 Valve proving pressure switch (mounted on the valve assembly)
- 7 Double gas valve assembly
- 8 Gas butterfly valve
- 9a Pressure gauge with push-button valve (standard)
- 9b Pressure gauge with push-button valve (accessory)
- 10 SV-D ignition gas solenoid valve
- 11 Burner
- 12 LPG pressure regulator (accessory)
- 13 Hose rupture protection (accessory)
- 14 W-MF SE multi-function assembly
- 15 LPG tank (by others)
- 16 Sub-assembly fitted to burner at works
- 17 VGG10 ignition gas valve with SKP15
- 18 VGG10 ignition gas valve with SKP25

Gas side, WKGMS 80
versions NR/1SF



Note:
See pages 36–37 for optional ignition arrangements.

-  General actuator/coil
 -  Electromagnetic coil
 -  Hydraulic actuator
 -  Burner with separate ignition burner (variants D–F, page 31)
- p_i = Inlet pressure before the ball valve
- p_o = Outlet pressure after the regulator
-  Pressure regulator
 -  Shutoff assembly

Valve train selection

High-pressure (HP) gas supply details

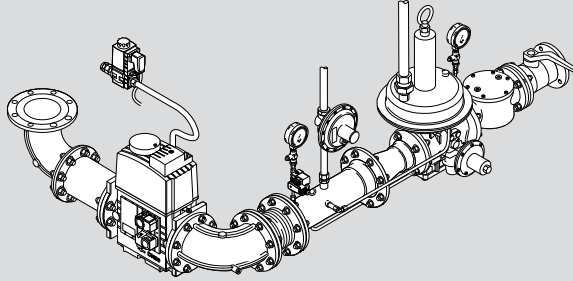
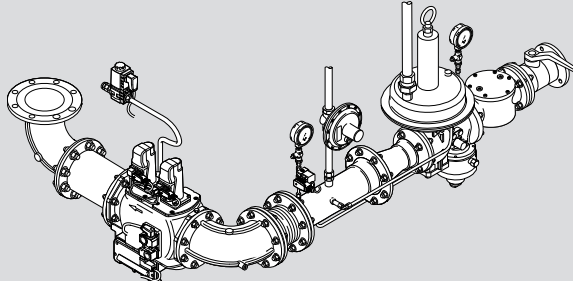
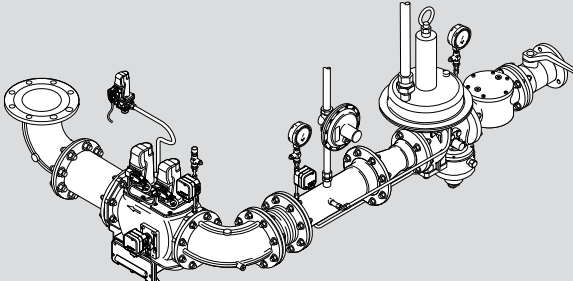
HP Standard	<p>High-pressure gas supply, standard version Used when:</p> <ul style="list-style-type: none"> – The gas flow pressure at maximum burner load is > 300 mbar. – The regulated pressure p_o, together with the combustion chamber resistance does not exceed 210 mbar. – The MOP⁵⁾ does not exceed 1000, 2500, 4000, or 5000 mbar, depending on regulator type. <p>Refer to Print No. 83001202 for component layout.</p>	
HP So	<p>High-pressure gas supply, So version Used when:</p> <ul style="list-style-type: none"> – The gas flow pressure at maximum burner load is > 500 mbar. – The regulated pressure p_o, together with the combustion chamber resistance is in the range of 210–350 mbar. – The MOP⁵⁾ does not exceed 4000, 5000, 10 000, or 16 000 mbar, depending on regulator type. <p>Refer to Print No. 83525902 for component layout.</p>	
HP SoH	<p>High-pressure gas supply, SoH version Used when:</p> <ul style="list-style-type: none"> – The gas flow pressure at maximum burner load is > 500 mbar. – The regulated pressure p_o, together with the combustion chamber resistance is in the range of 350–500 mbar. – The MOP⁵⁾ does not exceed 4000, 5000, 10 000, or 16 000 mbar, depending on regulator type. <p>Refer to Print No. 83525902 for component layout.</p>	

Layout of the valve train (vertical burner installation)

The "offset gas butterfly and valve assembly" option is very strongly recommended because of the increased heat radiation due to vertical boiler design and the high temperatures of media such as thermal fluid.

Support of the valve train

The gas valve train should be properly supported in accordance with the site conditions. See the Weishaupt accessories list for various valve train support components.

Compensator

To enable a tension-free mounting of the valve train, the fitting of a compensator is strongly recommended.

Gas meter

A gas meter must be installed to measure gas consumption during commissioning and servicing.

Optional thermal shutoff (when required by local regulations)

Integrated into the ball valve of screwed valve trains. A separate component with HTB seals fitted before the ball valve on flanged valve trains.

Safeguarding of the high-pressure gas supply in the event of a failure

The supplier must safeguard the gas flow pressure such that, in the event of failure, it cannot exceed the MIP²⁾ of the burner's gas valve train.

¹⁾ MOP = Maximum Operating Pressure

²⁾ MIP = Maximum Incidental Pressure (= MOP x 1.1)

HP Standard / So / SoH

Gas side, WKG(L) 40–80, WKGMS 40–70
versions ZM / NR / 1LN / 3LN / 1SF / VSF / 3SF

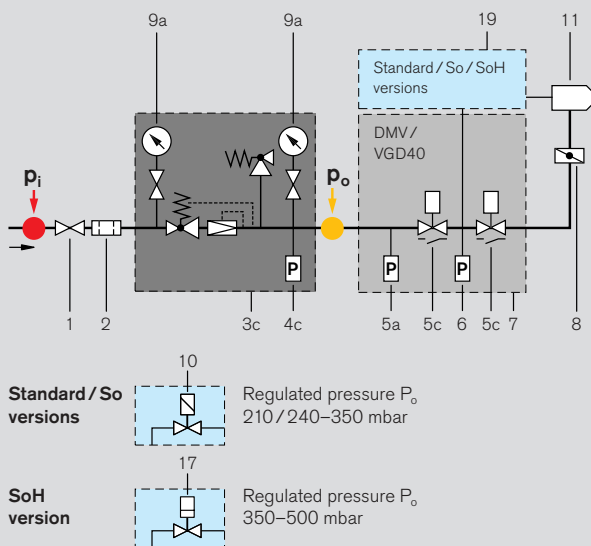



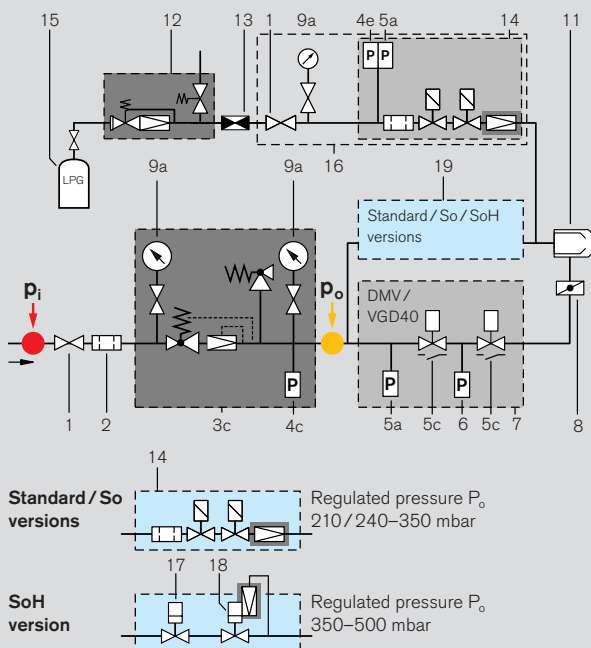

Gas side, WKGMS 80 versions NR / 1SF



- 1 Ball valve
- 2 Gas filter
- 3c High-pressure regulator incl. SSV / SRV
- 4c High gas pressure switch on screwed and flanged valve trains (mounted on the outlet side of the assembly)
- 4e High gas pressure switch (mounted on the LPG ignition burner assembly)
- 5a Low gas pressure switch (mounted on the valve assembly inset)
- 5b Additional low gas pressure switch in conjunction with VGD40
- 5c "Open" position indicator switch in conjunction with VGD40 and 2x SKP15
- 6 Valve proving pressure switch (mounted on the valve assembly)
- 7 Double gas valve assembly
- 8 Gas butterfly valve
- 9a Pressure gauge with push-button valve (standard)
- 10 SV-D ignition gas solenoid valve
- 11 Burner
- 12 LPG pressure regulator (accessory)
- 13 Hose rupture protection (accessory)
- 14 W-MF SE multi-function assembly
- 15 LPG bottle (by others)
- 16 Sub-assembly fitted to burner at works
- 17 VGG10 ignition gas valve with SKP15
- 18 VGG10 ignition gas valve with SKP25
- 19 Standard / So / SoH version ignition assembly variants

Note:

See pages 36–37 for optional gas ignition arrangements.

-  General actuator/coil
-  Electromagnetic coil
-  Hydraulic actuator
-  Burner with separate ignition burner (variants D–F, page 31)

P_i = Inlet pressure before the ball valve

P_o = Outlet pressure after the regulator

 Pressure regulator

 Shutoff assembly

Fuel systems

Oil and dual-fuel burners (oil side)

WKL 40-80

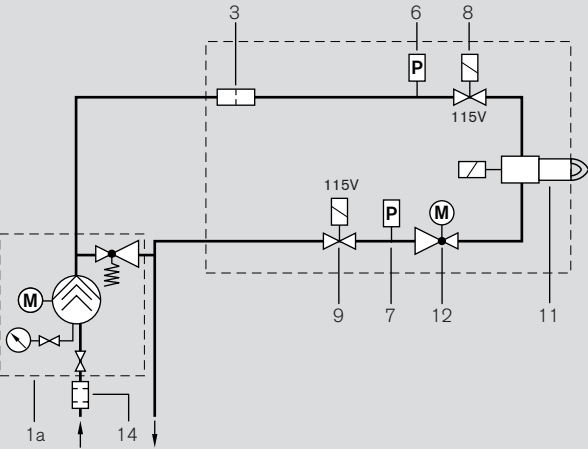

WKL 40-50

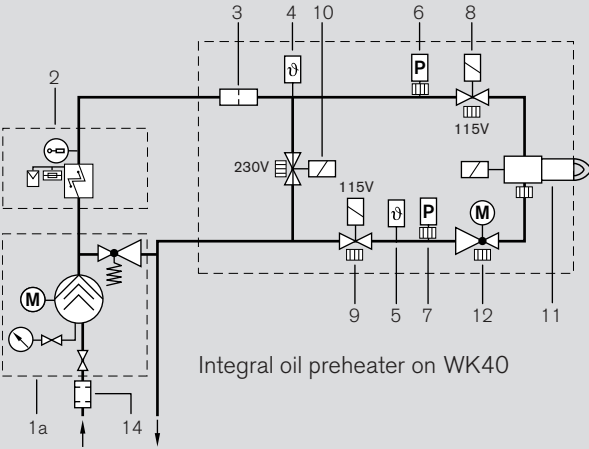

WKMS 70-80

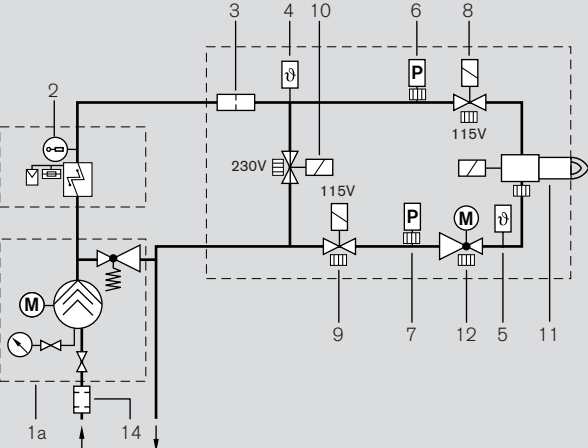

Gas oil ignition burner, WKMS 80

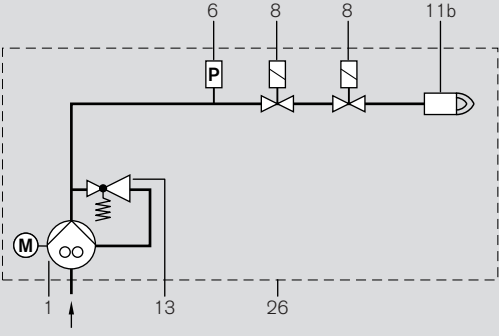

WKL 40–50 multiflam®

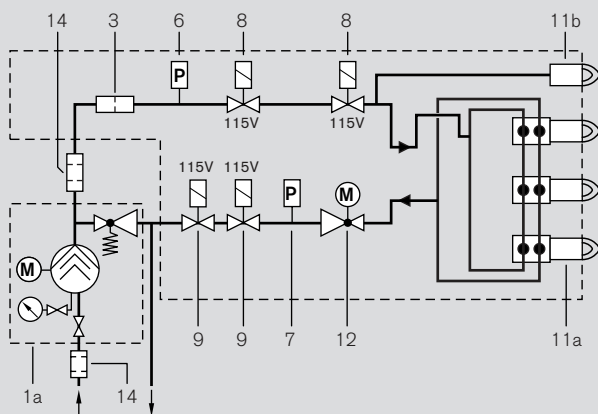

WKL 70–80 multiflam®

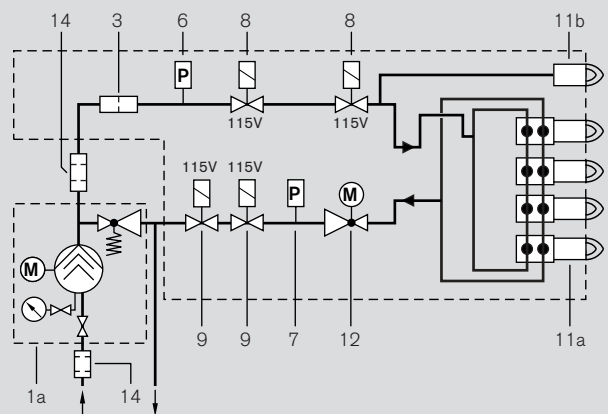

LPG ignition pilot, WKMS 40–70

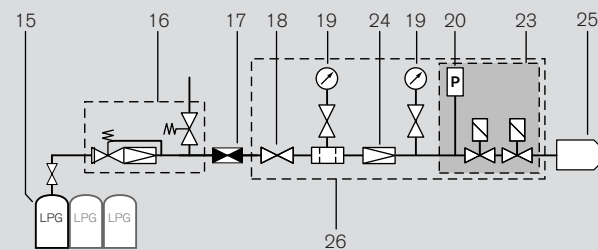

Oil-firing burner with gas ignition

LPG ignition burner, WKMS 80

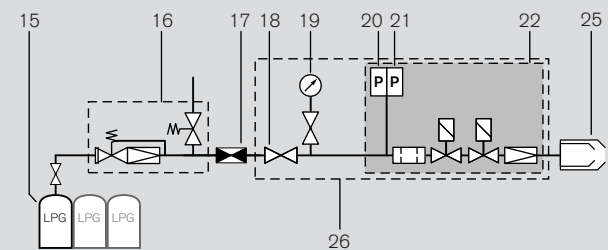

Oil-firing burner with gas ignition

- 1 Oil pump
- 1a External pump station with pressure maintenance
- 2 Oil preheater
- 3 Strainer
- 4 Temperature sensor in supply
- 5 Temperature sensor in return
- 6 Low-pressure switch
- 7 High-pressure switch
- 8 Solenoid valve in supply (fitted in the direction of flow)
- 9 Solenoid valve in return (fitted against the direction of flow)
- 10 Bypass solenoid valve (normally open)
- 11 Solenoid valve assembly
- 11a Nozzle head with secondary nozzles
- 11b Nozzle head with primary nozzle
- 12 Oil regulator

- 13 Pressure regulating valve
- 14 Filter
- 15 LPG bottle (supplied by others)
- 16 LPG pressure regulator (accessory)
- 17 Hose rupture protection (accessory)
- 18 Ball valve
- 19 Pressure gauge with push-button valve
- 20 Low gas pressure switch
- 21 High gas pressure switch
- 22 W-MF SE multi-function assembly
- 23 DMV gas solenoid valve assembly
- 24 FRS gas pressure regulator
- 25 Burner
- 26 Sub-assembly fitted to burner at works

Perfect ignition Helping safety and environmental protection

Direct oil ignition
Version 1.1

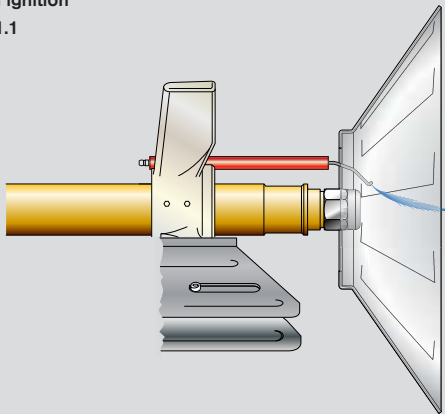

HFO ignition with gas ignition pilot
Version 1.2

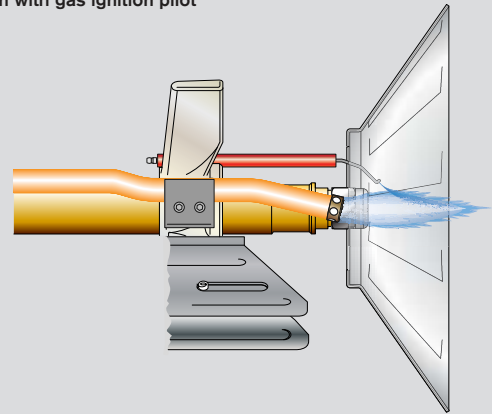

HFO ignition with gas ignition burner
Version 2

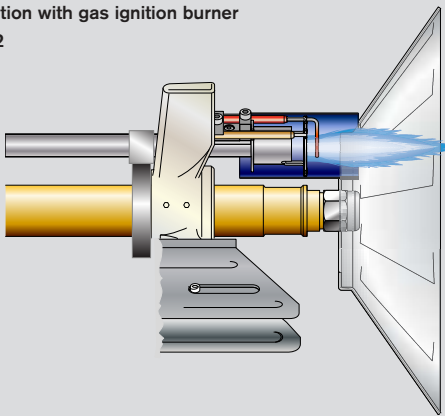

HFO ignition with gas oil ignition burner
Version 3

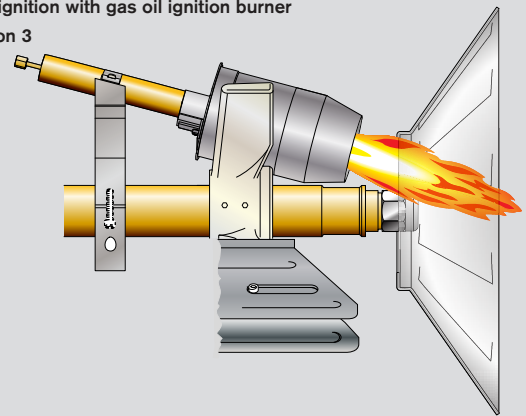

The reliable ignition of a broad range of fuel types and volumes calls for the use of suitable ignition devices and appropriate control programs.

The W-FM 200 combustion manager has various control variants which affect at what point an ignition spark is created and when fuel valves open and close.

Gaseous and low-viscosity liquid fuels are easily ignited. Modern electronic ignition units and high-voltage electrodes are used to create an electric arc, and the heat of that spark sets fire to the gas or to the oil vapour.

Igniting high-viscosity liquid fuels with minimal emissions, however, requires a different type of ignition system. Weishaupt offers several special units, from which the best-suited for any given application can be selected.

The key issue is always which fuels are available. Dual-fuel burners can make use of their gas ignition pilot when firing heavy oil. Furthermore, by equipping the system with two ignition gas lines, there is always a choice to be made between either natural gas or LPG ignition as required.

For the WKMS80 single-fuel burner there is a choice of two ignition burners. The gas version is a self-contained ignition burner with diffuser, flame tube, ignition electrode and flame monitoring. Depending on the installation it can be fired using either LPG or natural gas. The oil version is used when, for example, regulations preclude the use of gas. It too is a complete burner unit comprising oil pump, oil nozzle, igniter, diffuser, and flame tube. The ignition burner is fired using gas oil and has a rating of approximately 50 kW. Its flame ignites the pre-warmed, high-viscosity oil quickly, cleanly, and reliably.

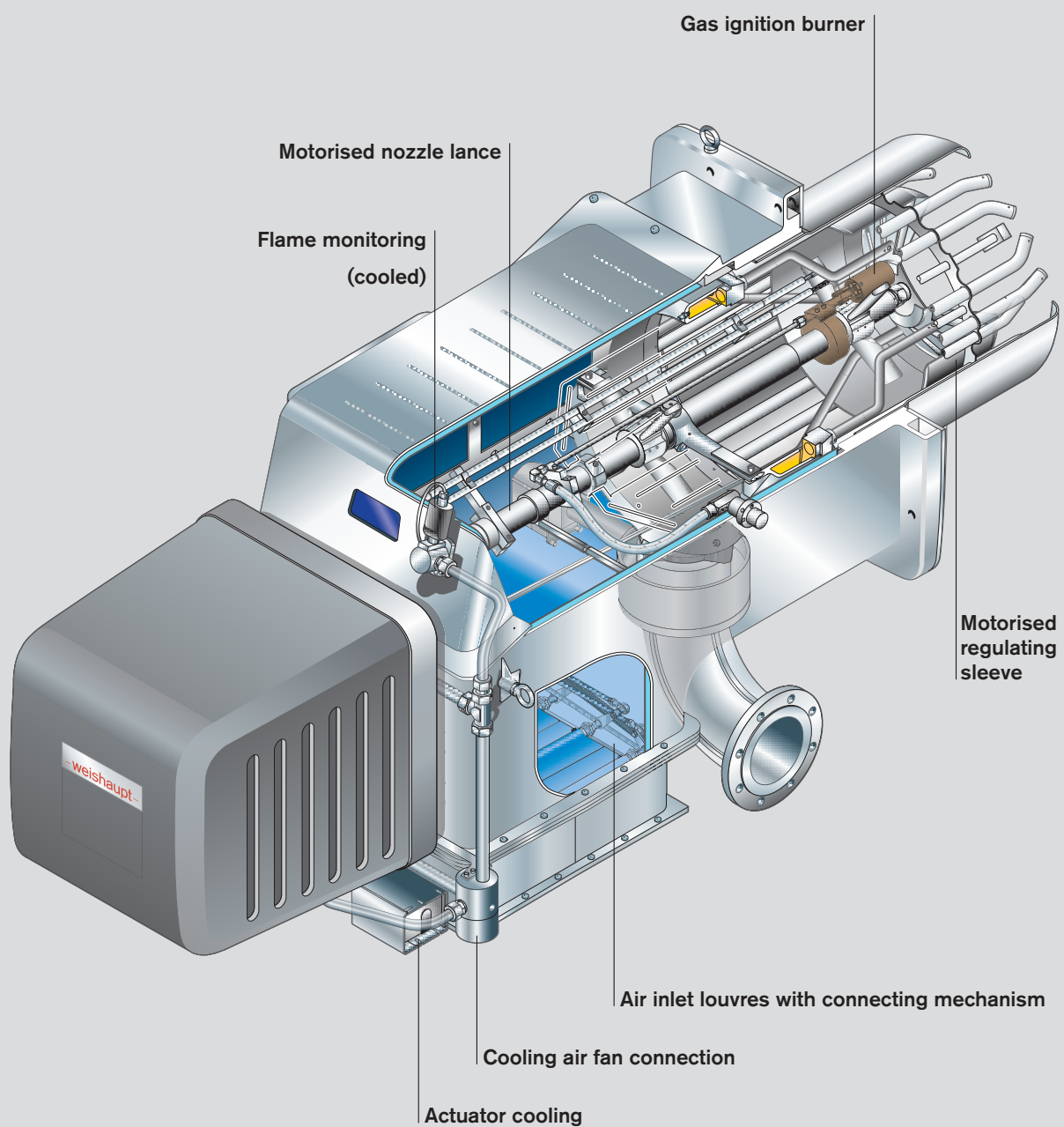

WK-series dual-fuel burner in hot-air execution with gas ignition burner

Fuel systems

General overview of ignition variants

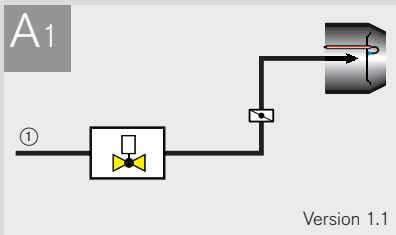

Gas: Ignition via electrode

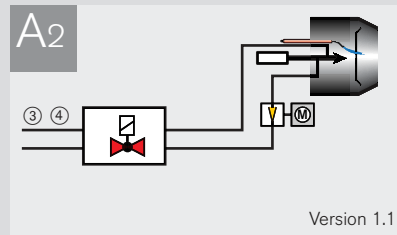

Oil: Ignition via electrode (standard)

- ① Main gas
- ② LPG
- ③ High-viscosity liquid fuel
- ④ Low-viscosity liquid fuel

Details regarding the valves and governors used on different sizes and versions of WK-series burners are available upon enquiry.

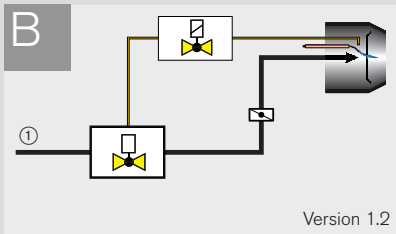

Gas: Ignition via ignition gas pilot
WKGL / WKGMS burners in combination with A2

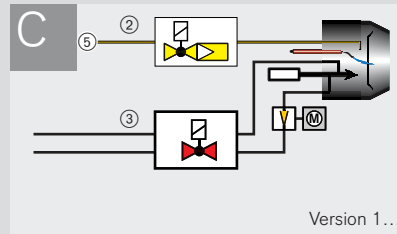

HFO: Ignition via LPG ignition unit
WKGMS burners in combination with B

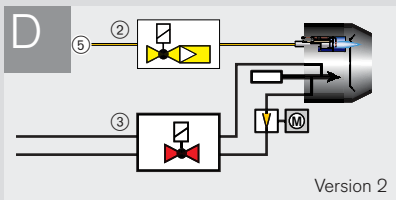

HFO: Ignition via LPG ignition burner

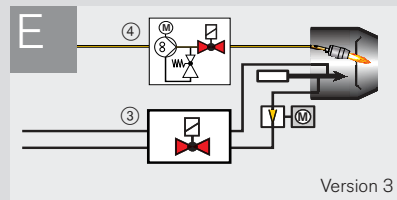

HFO: Ignition via gas oil ignition burner

Accessory for LPG ignition



- ⑤ **Complete set**
(Part No. 271 805 26 012) comprising:
 - ⑥ Pressure regulator for 11 / 33 kg LPG bottle
 - ⑦ Hose rupture protection
 - ⑧ 3 m hose

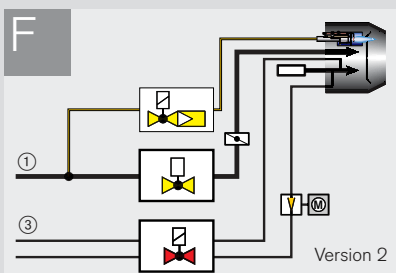

Dual-fuel: Gas and HFO ignition via
main gas ignition burner

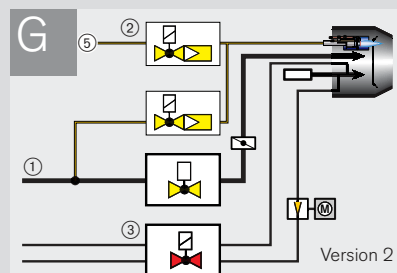

Dual-fuel: Gas and HFO ignition via
main gas ignition burner with
additional HFO ignition via LPG

Ignition variants by burner size and version

Variant	WK 40					Variant
	WKL	WKMS	WKG	WKGL	WKGMS	
A ₁			● ³⁾			A ₂ + B
A ₂	●	●		●	●	
B			●			B + C
C		○			○	

● Standard
○ Optional

³⁾ WKG40 ZMH-LN ignites from the main gas line

Variant	WK 50					Variant
	WKL	WKMS	WKG	WKGL	WKGMS	
A ₁						A ₂ + B
A ₂	●	●		●	●	
B			●			B + C
C		○			○	

● Standard
○ Optional

Variant	WK 70						Variant
	WKL	WKMS		WKG	WKGL	WKGMS	
		70/2-A vers. 1SF					
A ₁				● ³⁾			A ₂ + B
A ₂	●	●	●		●	●	
B				●			B + C
C		○			○		
D			○ ¹⁾				D
F						○ ¹⁾	F
G						○ ¹⁾	G

● Standard
○ Optional

¹⁾ W-FM 200 combustion manager required
³⁾ WKG70 ZM(H)-LN ignites from the main gas line

Variant	WK 80						Variant
	WKL	WKMS		WKG	WKGL	WKGMS	
		17.5 MW <	>				
A ₁							A ₁
A ₂	●	○ ²⁾			● ⁴⁾	○ ²⁾	A ₂ + B
B			● ¹⁾				
D		● ¹⁾	● ¹⁾				D
E			●				E
F						○ ¹⁾ ○ ¹⁾	F
G						● ¹⁾ ● ¹⁾	G

● Standard
○ Optional

¹⁾ W-FM 200 combustion manager required
²⁾ 1SF version excluded

Flame monitoring for demanding safety requirements



Testing and optimisation using a software tool

Flame monitoring plays a crucial role when it comes to reliability and safety.

Determination of the best method of flame monitoring takes into account not only the burner and the fuel to be combusted, but also how the system operates and the conditions inside the combustion chamber.

Heat generators with one flame per combustion chamber are easier to monitor than those with multiple flames. In the latter case, it also depends whether the flames are firing into the combustion chamber from the same or opposing directions.

Biomass plant and waste incinerators need a flame monitoring system that is not affected by extraneous flames.

Weishaupt offers flame monitoring systems for gas, oil, and dual-fuel burners operating under the widest range of conditions.

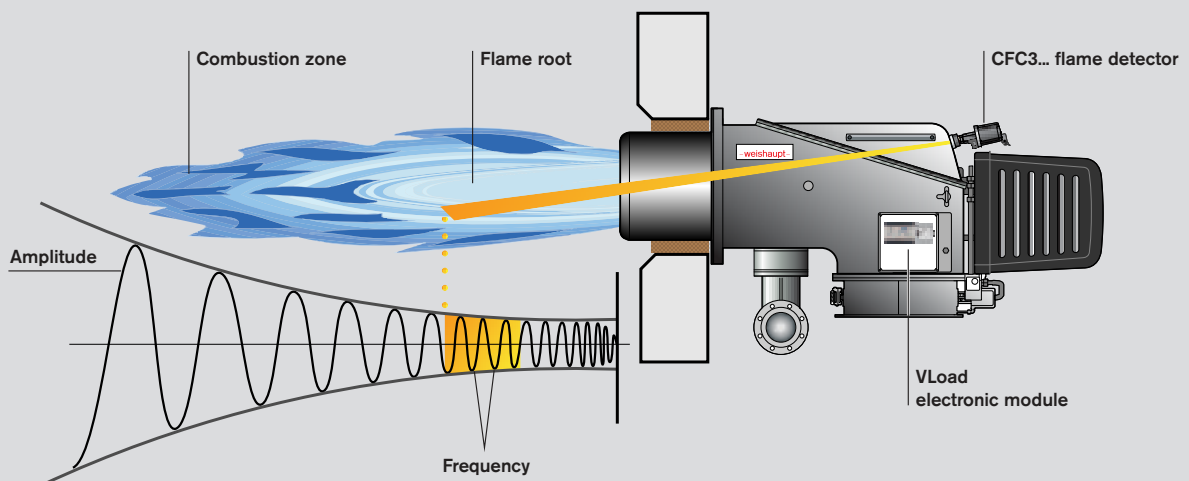

The constructive alignment of the CFC3... allows the detection range to be optimised

W-FC: Weishaupt Flame Control

Weishaupt Flame Control (W-FC) is a reliable flame monitoring system that is designed to meet demanding safety requirements and comply with the EN 298 standard for continuous operation.

W-FC 4.0 is for plant with multiple burners firing from the same direction into a single combustion chamber. The W-FC assembly utilises flame frequency to monitor each flame separately via a load-independent on and off threshold for each fuel. The CFC3... flame detector functions in series with the QRA73 flame sensor on the W-FM100 or W-FM200 combustion manager.

Note: If a turndown in excess of 4:1 or single-burner operation is required, the higher-specification W-FC 5.0 must be selected.

W-FC 5.0 is for plant with multiple burners firing from different directions into a single combustion chamber, and for process plant with various flame sources. The W-FC assembly monitors each flame separately via up to ten load-dependent switching thresholds for each fuel. The VLoad electronic module and its user-friendly software establishes a distinct differentiation from extraneous light sources specific to that plant. The CFC3... flame detector functions in parallel with the QRA73 flame sensor on the W-FM200 combustion manager.

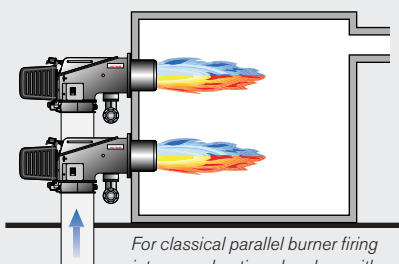

For classical parallel burner firing into a combustion chamber, with a maximum turndown of 4:1

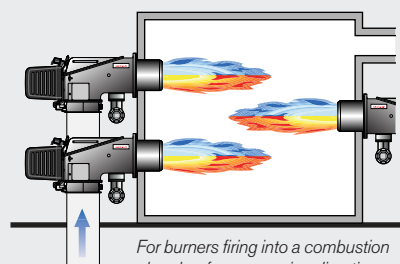

For burners firing into a combustion chamber from opposing directions, and for individual/staged firing of multiple burners

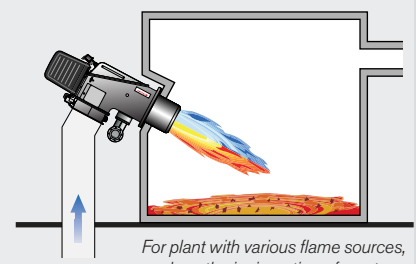

For plant with various flame sources, such as the incineration of waste or biomass, process plant, etc.

3LN-version burners: Emissions reduced by the multiflam® principle

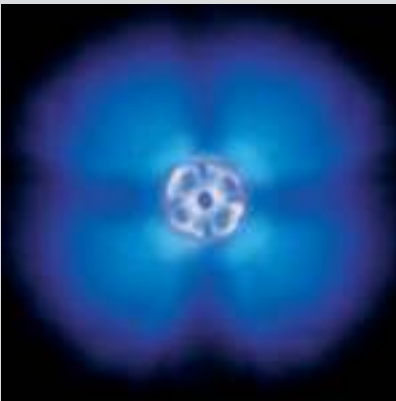

Flame image showing efficient combustion

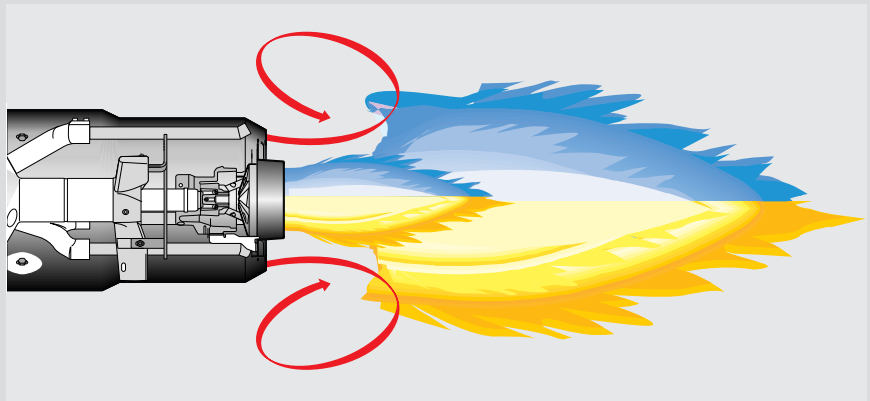

Schematic representation of the primary and secondary flames with internal recirculation

The multiflam® principle developed and patented by Weishaupt is an innovative way of reducing NO_x emissions from combustion plant to a minimal level.

At the heart of Weishaupt's multiflam® technology lies a special mixing assembly design. Fuel is distributed among several nozzles and combusted in a primary and a secondary flame. Temperature in the flame's core is considerably reduced, resulting in an effective reduction of nitrogen oxides.

The wide range of ratings across which multiflam® burners are now available is equally outstanding. All the way from the WM 10 monarch®-series burner right up to the WK 80 industrial-series burner, there is now a multiflam® burner for outputs ranging from 120 up to 23 000 kW.

Weishaupt multiflam® burners have been proving themselves in the field for 20 years. As fully fledged gas, oil, and dual-fuel burners, they are always the first choice for achieving low NO_x emission limit values without resorting to external measures.

However, the achievement of good combustion figures depends on more than just the burner. There are numerous additional parameters, such as the design of the heat generator, and the geometry and the thermal loading of its combustion chamber, that also play an important role. Furthermore, the medium temperature, combustion air temperature, and the air humidity are decisive. When the NO_x emissions for a particular application are guaranteed, the guarantee will always be with reference to certain constraints and system parameters.

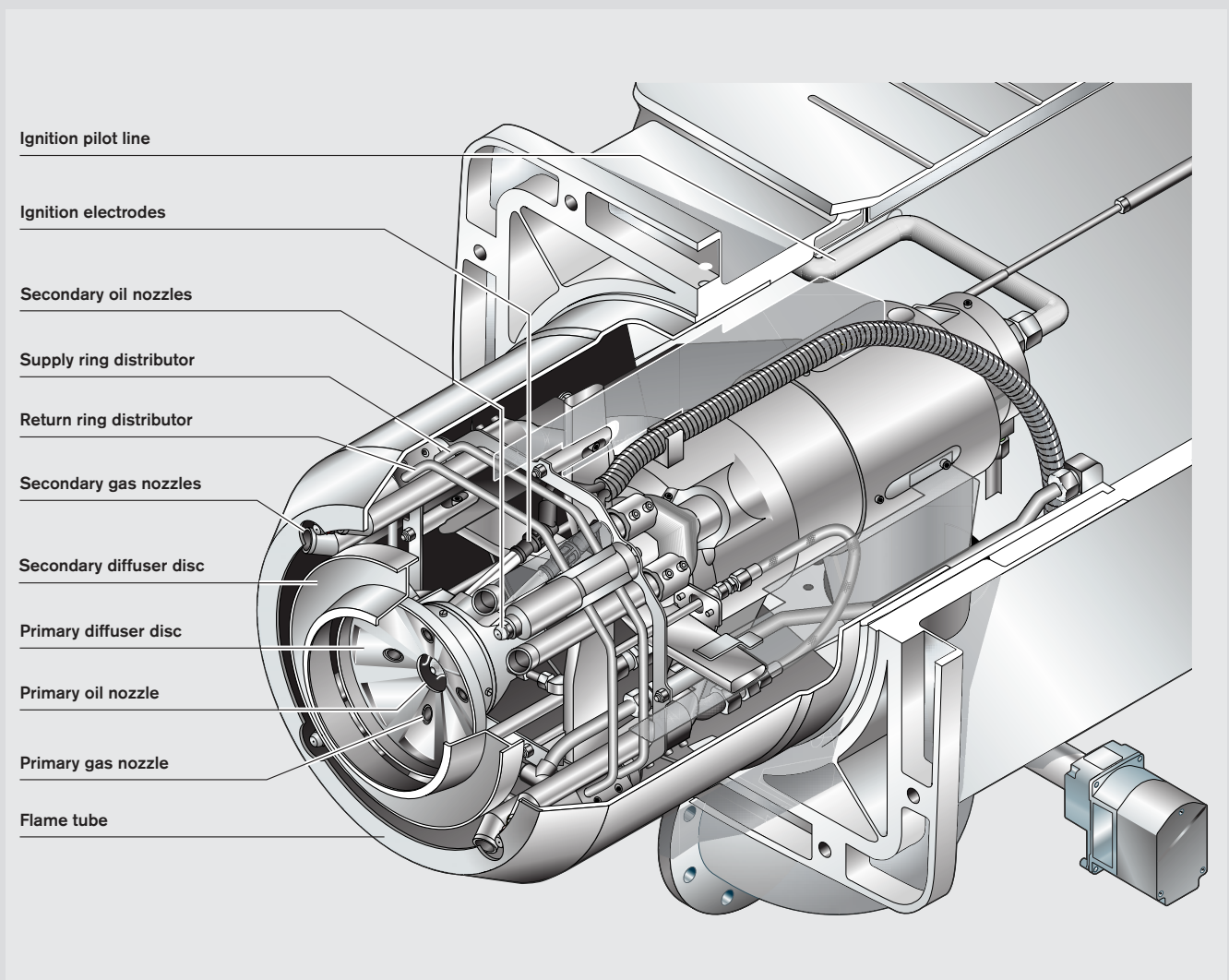

The multiflam® mixing assembly of a dual-fuel burner

Efficiency increases of up to 10 percent with 250 °C hot-air WK-series burners

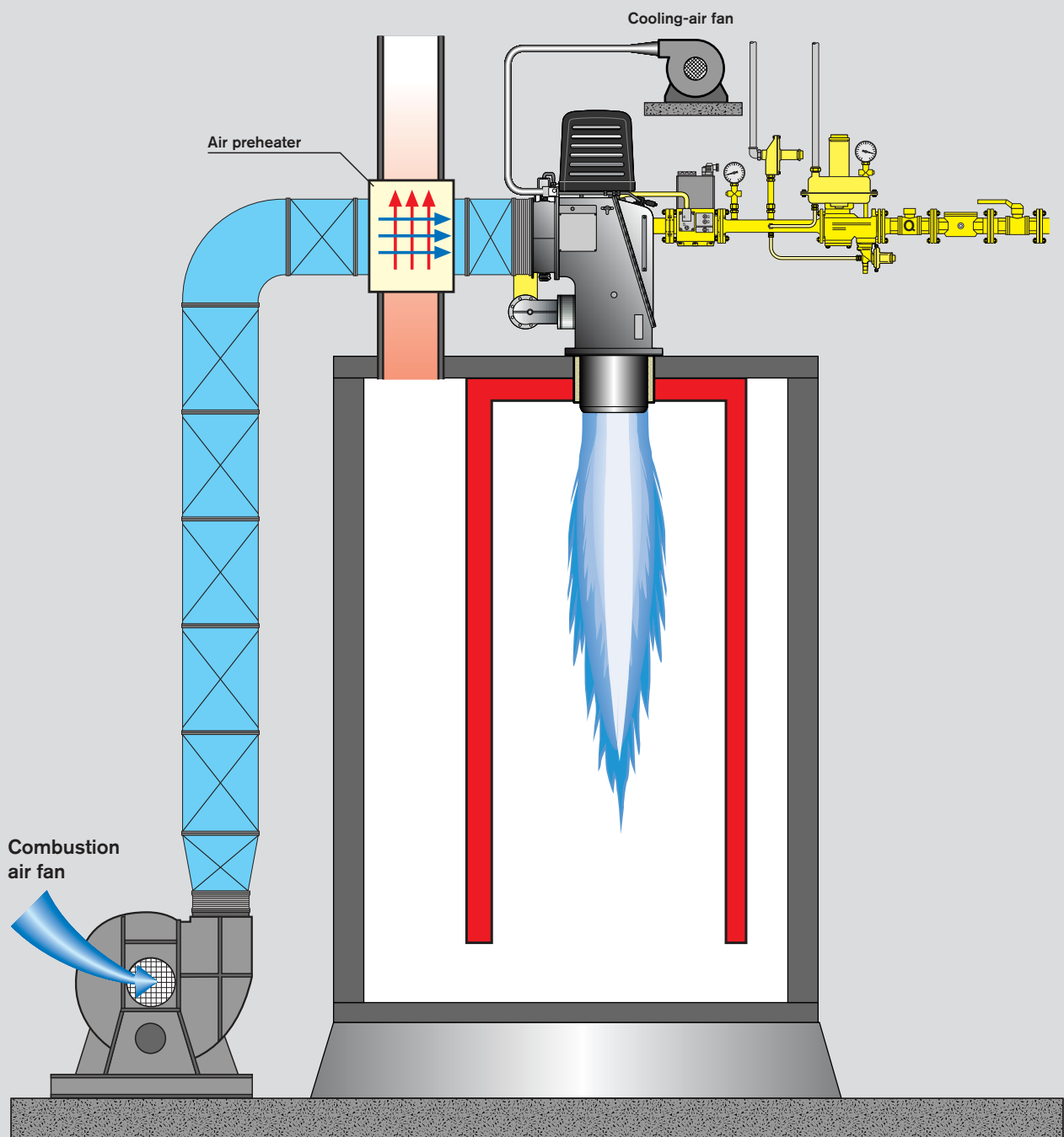

The principle of heat recovery with combustion air preheated up to a maximum of 250 °C.

Reduction in oxides of nitrogen with 250 °C hot-air multiflam[®] burners



Cooling air for actuators and flame monitoring

Weishaupt 3LN (multiflam[®]) and 4LN-version burners can now operate with preheated combustion air.

Heat generators with very high medium temperatures can exploit less of the heat in the flue gases. Consequently, flue gas temperatures are always higher than the medium temperature. Without additional heat exchangers, a lot of energy will be lost to the atmosphere and wasted. One way of utilising this energy is through the use of hot-air versions of the WK-series duobloc burners.

A cross-flow heat exchanger between the combustion air duct and the flue gas system draws heat from the hot flue gas and transfers it to the combustion air. Using this method, combustion air can be heated to temperatures of up to 250 °C, making efficiency increases of up to 10 percent possible.

Despite these extreme conditions, the burners can achieve NO_x values in the range of 100–150 mg/Nm³.

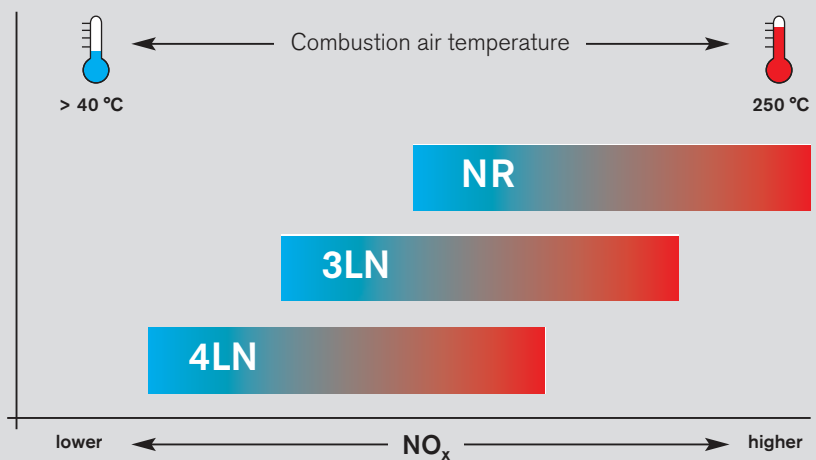

NO_x emissions on hot-air WK-series burners, comparing NR and multiflam[®] 3LN-version burners without flue gas recirculation and 4LN-version burners with flue gas recirculation

Improved efficiency with combustion air preheating

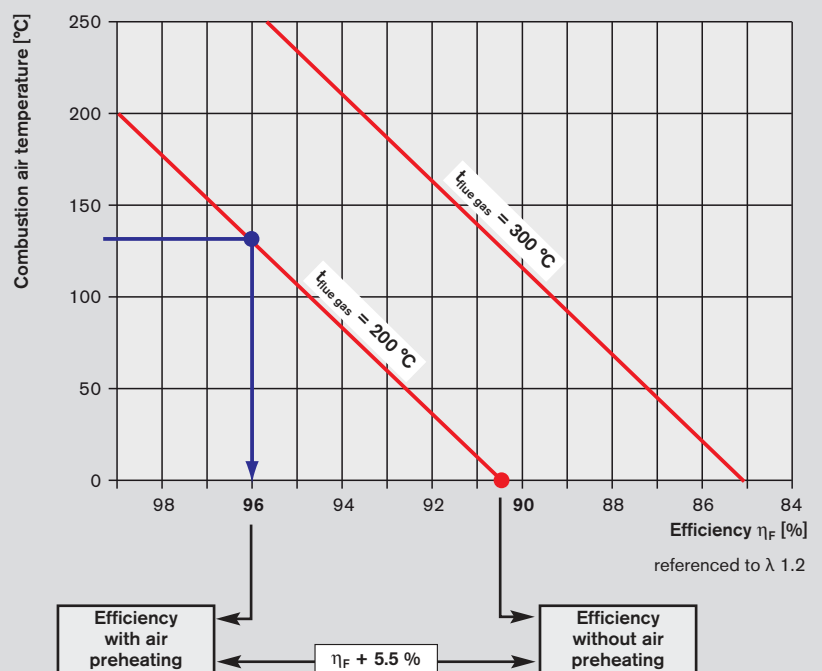



The 4LN-version mixing assembly of a WK-series burner – A further development of the well-proven 3LN-version multiflam® mixing assembly

Very high capacity, ultra-low emissions: The 4LN-version WK-series burners

Weishaupt 4LN-version gas burners are an innovative development that enables the world's most stringent NO_x emission limits to be met.

This further development brings about the general integration of external flue gas recirculation. The mixing assembly of the burner is based on familiar multiflam® technology that has been especially optimised for the admixture of flue gas.

Results from the lab and the field prove that this technology can always meet NO_x limits of 30 mg/kWh (natural gas E), provided certain conditions are met.

The Weishaupt FGR system does not require an additional fan to feed the flue gas to the burner.

The flue gases are instead drawn in by the combustion air fan. Low pressure develops in the mixing box, which allows flue gas to flow down the FGR pipe and into the fan. The burner's combustion manager controls the FGR butterfly valve, thus ensuring the flue gas volume is precisely dosed.

Servicing remains as simple as ever.

Only the fan is equipped with additional FGR components. The burner remains unchanged, making it easier to handle during commissioning and maintenance works. That saves both time and money.

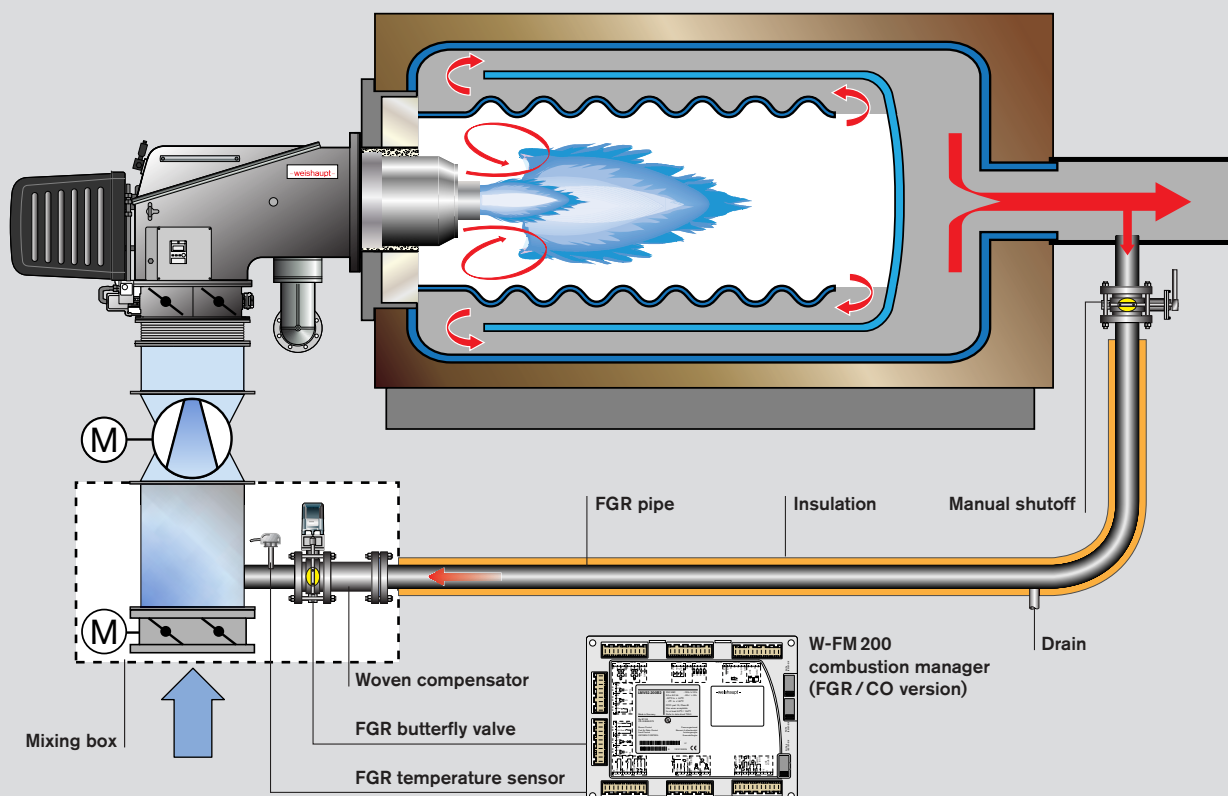

General arrangement of a flue gas recirculation system with WK-series burner and mixing box

Combustion air fan with mixing box for the Weishaupt flue gas recirculation system

Weishaupt mixing box

Weishaupt and its combustion air fan manufacturer worked together to develop the mixing box. It is fitted directly to the combustion air fan and forms a compact assembly with fixed dimensions. The mixing box consists of a housing with an integrated air damper register for suction control, a flanged connection for easy installation of the FGR butterfly valve, and a sleeve with inbuilt temperature sensor.

Benefits:

- Precise site plans can be drawn up.
- The manufacture of fully encapsulating sound absorbers can proceed without the need for on-site measurements.
- The fan is supplied fully pre-assembled.
- Installation times are reduced.
- The crucial factor for functionality – everything is in the right place.

Variable speed drive

Small details guarantee uncompromising quality and so Weishaupt goes a step further with its optional VSD too, which includes additional features such as:

- Fan motor with direction of rotation detection
- Earthed motor connections to prevent EMC interference
- Insulated motor bearings from 45 kW to prevent leakage current



Mixing box – Execution is dependent on the air feed arrangement



Fan motor with speed sensor for VSD

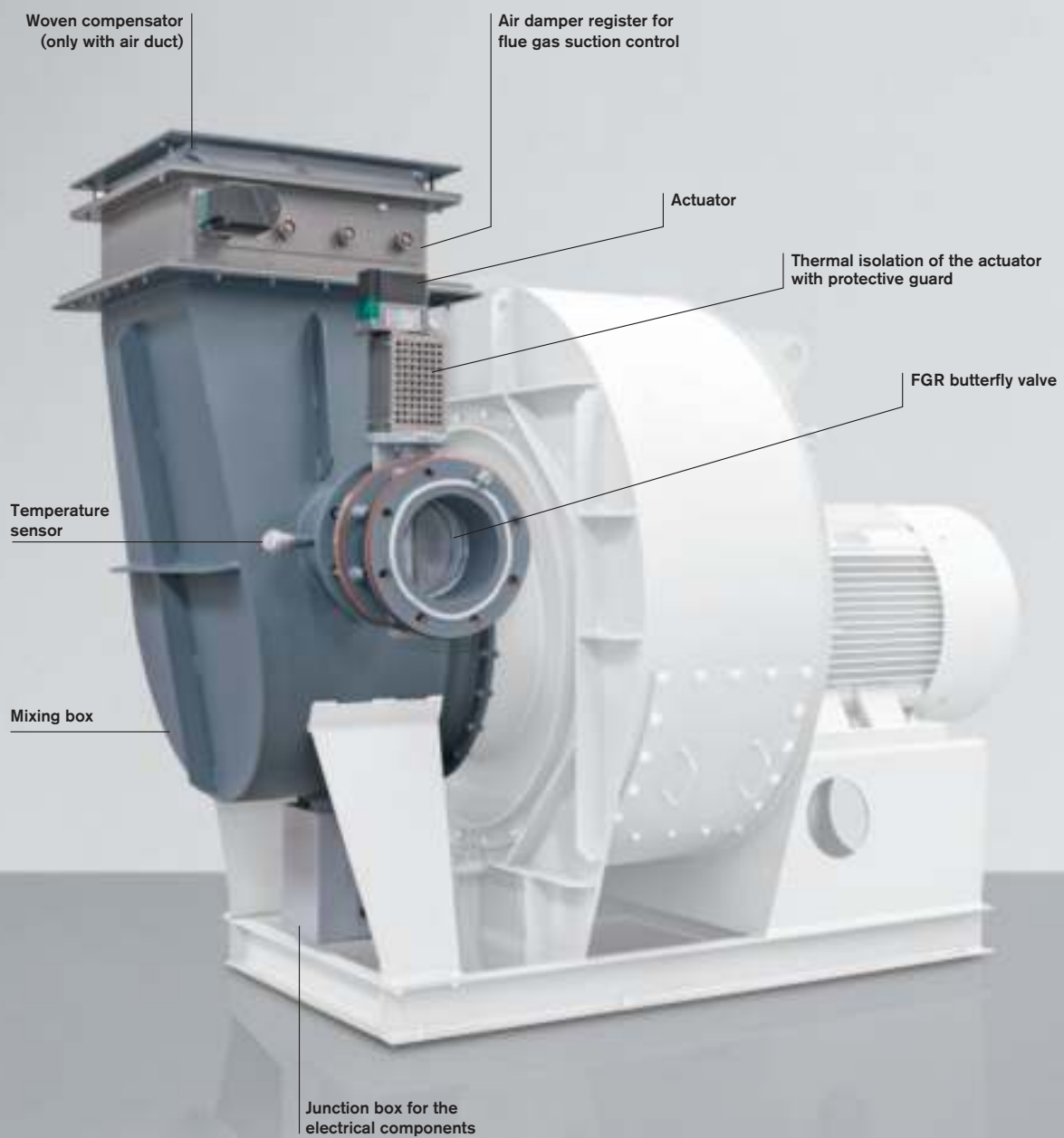

Mixing box for flue gas recirculation at the combustion air fan – air inlet from above (optional)

The right control panel: Individually made to your specifications



Every control panel is individually designed and built in the separate control panel production area

Weishaupt has been designing and manufacturing bespoke control panels of all kinds ever since the company was founded, not only for your typical heating system but also for complex building automation systems, and for thermal process plant.

The core areas for Weishaupt control panels are:

Burners

Burner and control panel from the same manufacturer, matched to each other at the factory:

- Manufactured to European and other international standards
- Digital combustion management with eBUS and Modbus interfacing (can be expanded to other bus protocols)
- Safety-oriented PLC control

Boilers

Safety-related requirements to comply with EN standards and country-specific regulations greatly affect the controls needed.

Weishaupt offers solutions for:

- LTHW boilers
- MTHW and HTHW boilers
- Steam boilers
- Boiler sequencing
- Optimisation of multi-boiler systems (Weishaupt MBC system)

Thermal process plant

Thermal process technology calls for numerous controls and regulators in addition to all of the appropriate burner controls. Typical applications include:

- Thermal fluid heaters
- Salt heaters
- Dryers
- Paint ovens
- Smelters

Marine

This highly specialised field places very particular demands on the equipment.

Weishaupt offers solutions that comply with the requirements of all of the usual classification societies (DNV-GL, LRS, ABS, RS, PRS, BV etc.) for the control of:

- Auxillary boiler systems
- Inert gas processing
- Heating

Weishaupt system technology: Perfectly matched components

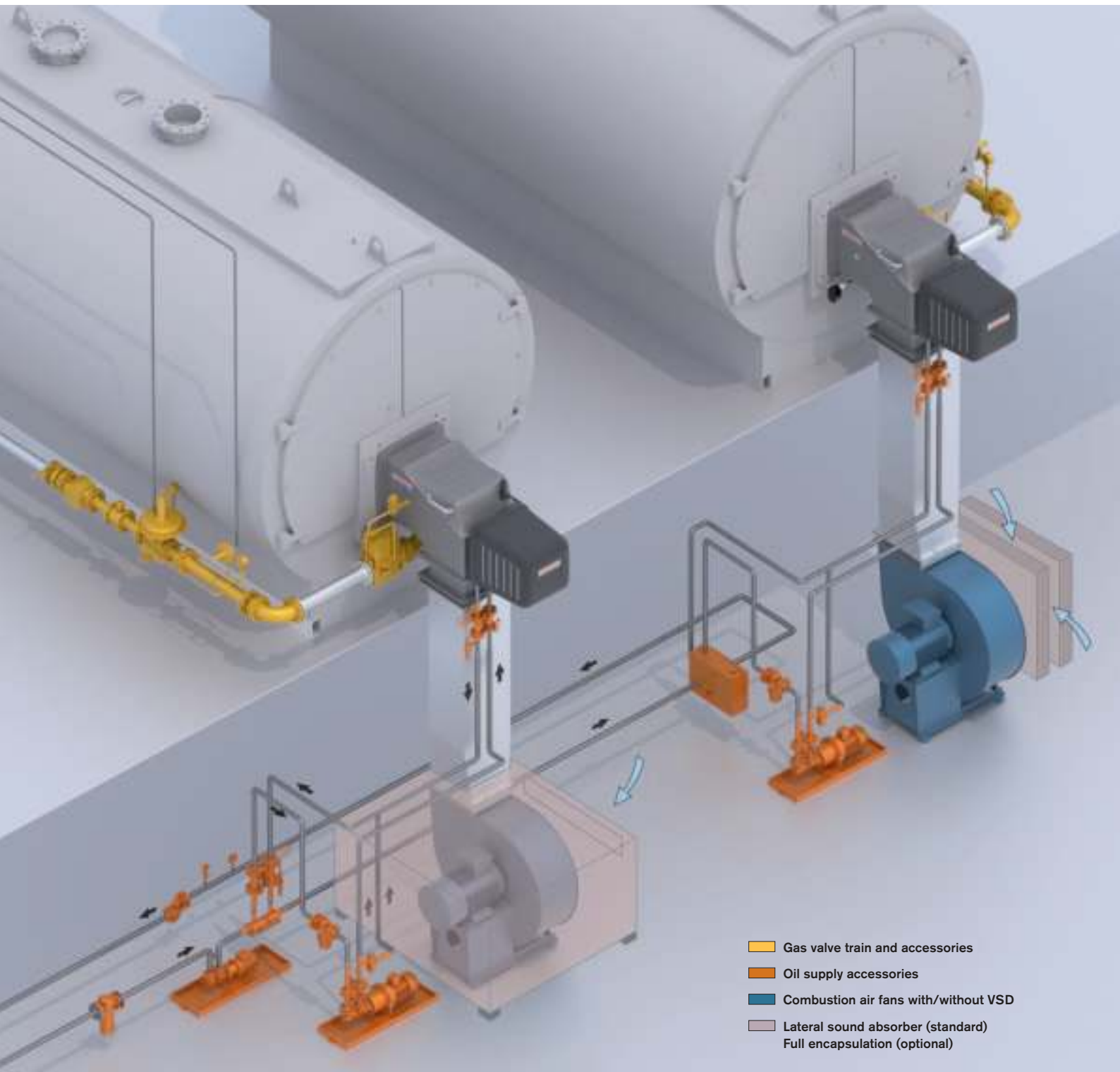

Key dimensions at a glance

Ambient air (ZM...)

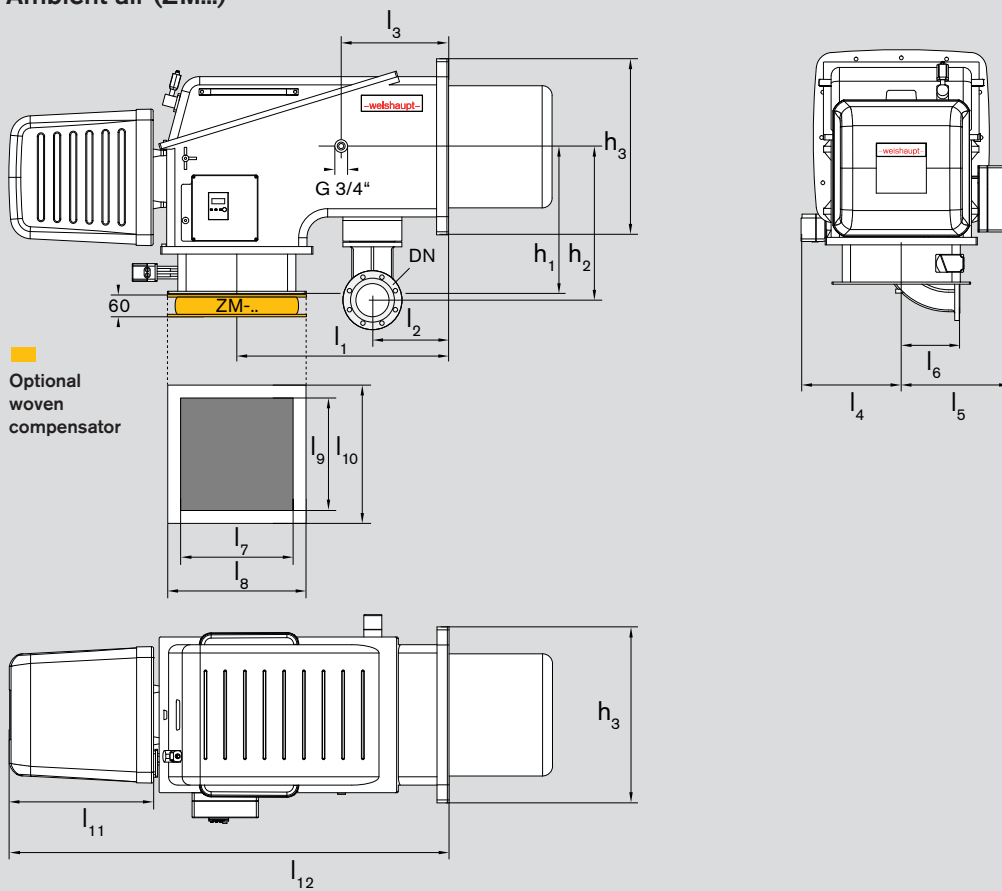

Hot air (ZMH...)

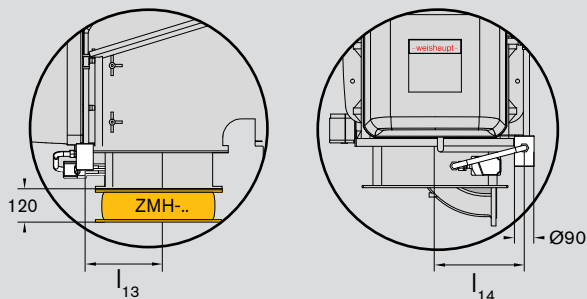

RD2 cooling-air fan

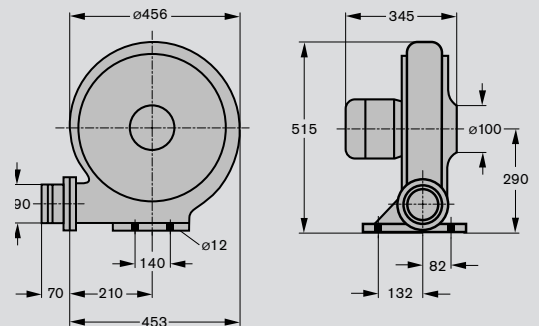

Type	DN	l ₁	l ₂	l ₃	l ₄	l ₅	l ₆	l ₇	l ₈	l ₉	l ₁₀	l ₁₁	l ₁₂	l ₁₃	l ₁₄	h ₁	h ₂	h ₃
WK40	65	388	116	116	313	340	140	226	336	264	368	452	1046	231	255	444	384	400
WK50	80	528	158	158	373	404	165	270	403	370	495	452	1212	258	311	518	464	540
WK70	100	730	188	313	454	466	205	418	548	500	630	650	1689	300	360	628	589	700
WK80	150	1023	368	522	486	524	283	556	670	556	670	697	2124	393	410	708	741	850

Weishaupt reserve the right to make changes in light of future developments. Additional burner dimensions and oil-side connection details are available on request.

Heat generator preparation

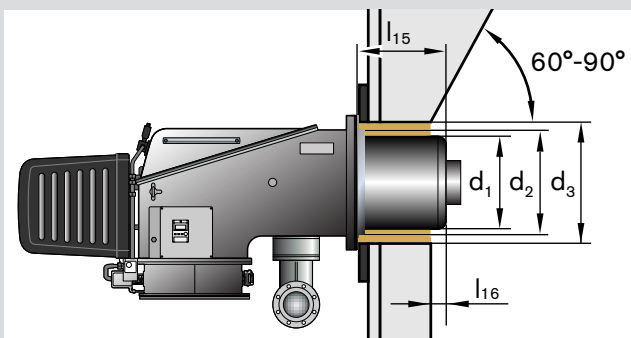

■ The space between the combustion head and the refractory should be filled with a resilient, non-solid insulating material, such as Cerafelt.

Maintenance-friendly combustion head:

On all burner versions, the standard-length combustion head can be inserted and withdrawn through the service opening in the burner housing.

¹⁾ Please enquire regarding combustion head extensions.

Type	Size	Vers. ZM(H)...	d ₁	d ₂	d ₃	l ₁₅ ¹⁾	l ₁₆
WK...	40/1		250	280	290	260	≥ 0
WK...	40/2		261	280	290	260	≥ 0
WK...	40/2	LN	296	280	320	424	≥ 0
WKG(L)	40/2	3LN	256	280	290	412	≥ 50
WK...	50/1	NR/1LN	290	380	390	307	≥ 0
WKG(L)	50/1	3LN	296	380	390	380	≥ 50
WK...	50/2	NR	350	380	390	337	≥ 0
WKG(L)	50/2	1LN	350	380	390	452	≥ 0
WKL(MS)	50/1		290	380	390	337	≥ 0
WKL(MS)	50/2		350	380	390	392	≥ 0
WKG(L)	50/2	3LN	344	380	390	501	≥ 50
WK...	50/2	1SF	350	380	390	337	≥ 0
WK...	70/1	NR	400	518	530	347	≥ 0
WK...	70/3	NR	480	518	530	462	≥ 0
WKG	70/1	LN	406	518	530	457	≥ 0
WKG(L)	70/1	1LN	406	518	530	439	≥ 0
WKG(L)	70/2	LN/1LN	480	518	530	477	≥ 0
WKG(L)	70/0	3LN	409	518	530	472	≥ 60
WKG(L)	70/1	3LN/4LN	444	518	530	475	≥ 60
WKG(L)	70/3	3LN/4LN	480	518	530	475	≥ 60
WK...	70/1	1SF	400	518	530	347	≥ 0
WK...	70/2	1SF	480	518	530	362	≥ 0
WKL(MS)	70/1		400	518	530	417	≥ 0
WKL(MS)	70/2		480	518	530	422	≥ 0
WK...	80/3	NR	590	590	640	500	≥ 0
WKG(L)	80/1	3LN/4LN	540	558	640	510	≥ 70
WKG(L)	80/2	3LN/4LN	540	558	640	510	≥ 70
WK...	80/3	1SF	600	600	640	480	≥ 0
WKG	80/4	VSF	590	590	640	500	≥ 0
WKG	80/5	VSF	590	590	640	500	≥ 0
WKG	80/6	3SF	618	618	650	500	≥ 0

Mounting-plate drilling dimensions

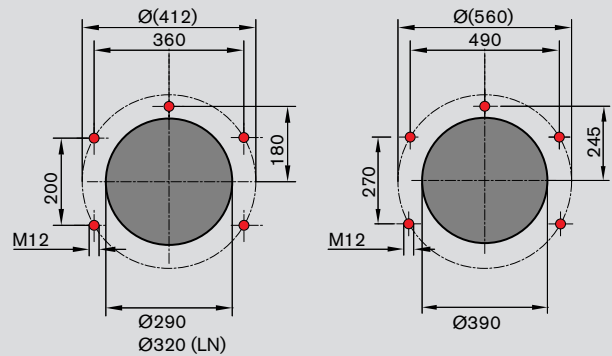

WK40

WK50

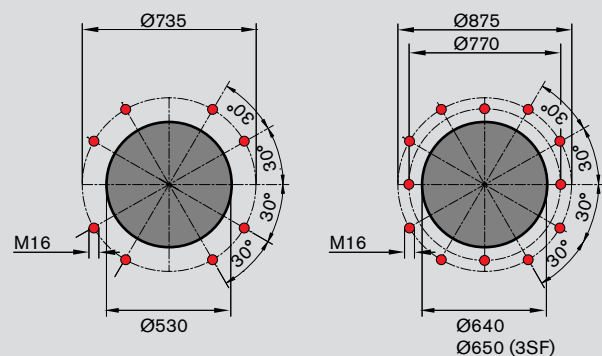

WK70

WK80

Overview of options, installation positions, and weights

Vertically firing Weishaupt burners (based on ZMH burners) have been especially designed for use on vertical plant, such as steam boilers, thermal fluid heaters, and process applications.

Reliable operation: The safety-critical components, such as the gas butterfly valve and its actuator, gas valve assembly, and gas pressure switches, are securely located away from high-temperature zones to ensure their reliable operation. The offset position of the ignition gas valve protects it from high levels of radiant heat from the heat exchanger.

Vertical execution

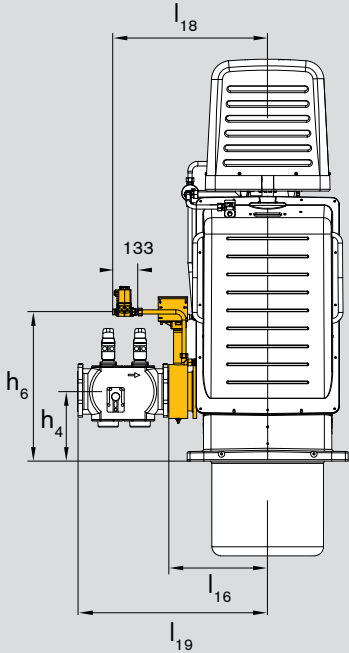
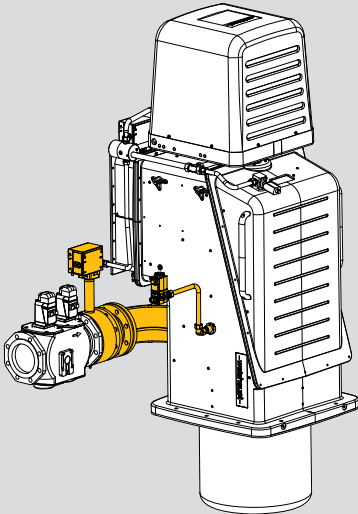

Optional

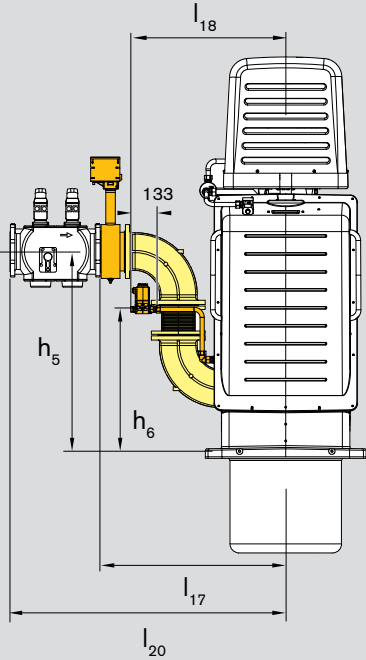
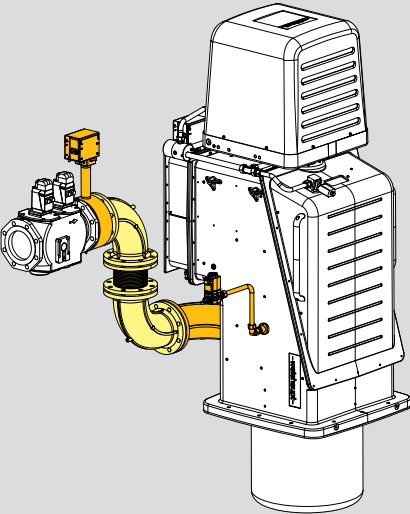

Optional

Extended option (with accessory components)

Vertical-execution dimensions

	Burner flange to butterfly valve outlet DN	Gas valve assembly DN	l_{16} ¹⁾	l_{17}	l_{18}	l_{19} ¹⁾	l_{20}	h_4	h_5	h_6
			WK.. 40	65	1 1/2"	492	686	641	841 ²⁾	1035 ²⁾
		2"	492	686	641	881 ²⁾	1075 ²⁾	116	502	382
		65	492	686	641	784	978	116	502	382
		80	492	686	641	991 ²⁾	1185 ²⁾	124	510	382
		100	–	686	641	–	1237 ²⁾	–	521	382
		125	–	686	641	–	1317 ²⁾	–	533	382
WK.. 50	80	2"	469	801	697	862 ²⁾	1192 ²⁾	158	594	424
		65	469	801	697	948 ²⁾	1280 ²⁾	166	601	424
		80	469	801	697	781	1113	158	594	424
		100	469	801	697	1030 ²⁾	1362 ²⁾	169	605	424
		125	469	801	697	1105 ²⁾	1437 ²⁾	182	617	424
WK.. 70	100	65	589	1001	760	1080 ²⁾	1492 ²⁾	207	723	579
		80	589	1001	760	1110 ²⁾	1522 ²⁾	199	715	579
		100	589	1001	760	941	1353	188	704	579
		125	589	1001	760	1227 ²⁾	1639 ²⁾	201	717	579
		150	589	1001	760	1320 ²⁾	1732 ²⁾	215	731	579
WK.. 80	150	100	522	976	815	1123 ²⁾	1577 ²⁾	395	1121	788
		125	522	976	815	1160 ²⁾	1630 ²⁾	382	1108	788
		150	522	976	815	1004	1458	368	1094	788

¹⁾ Including horizontal intermediate flange (not shown) ²⁾ Including concentric reducer (not shown)

Burner ⁷⁾ (kg)

	WKG	WKL	WKMS	WKGL	WKGMS
WK.. 40	120	140 ³⁾ / 125 ⁵⁾	165 ^{3,4)} / 130 ^{5,6)}	150 ³⁾ / 135 ⁵⁾	170 ^{3,4)} / 140 ^{5,6)}
WK.. 50	165	160	165	165	170
WK.. 70	290	290	300	310	320
WK.. 80	440	420	430	460	470

³⁾ Burner-mounted oil pump ⁴⁾ Burner-mounted oil preheater ⁵⁾ Separate oil pump ⁶⁾ Separate oil preheater

⁷⁾ Masses are approximate and exclude gas valve trains

Gas valve train ⁸⁾ (kg)

	1 1/2"	2"	DN 65	DN 80	DN 100	DN 125	DN 150
WK.. 40	13	14	26	32	44	–	–
WK.. 50	–	14	30	31	46	41	–
WK.. 70	–	–	33	37	46	43	52
WK.. 80	–	–	–	–	59	54	50

⁸⁾ Masses are approximate and encompass the double gas valve assembly (incl. gas ignition pilot, if applicable) and connecting pipework to the gas butterfly valve.

Combustion air fans: Sound attenuation and housing arrangement

Lateral sound absorber

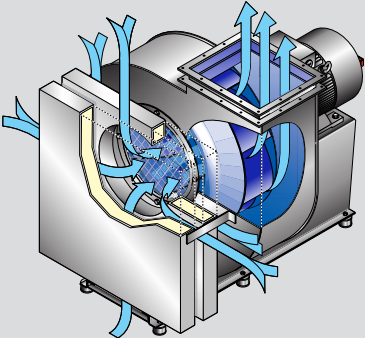

Air inlet sound absorber

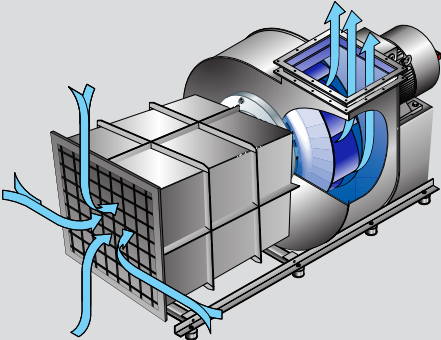

Full encapsulation

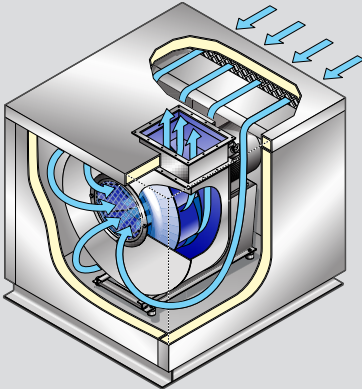

Combustion air fan housing arrangement

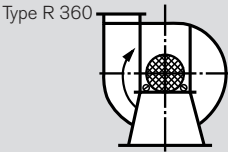
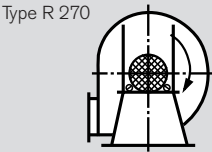
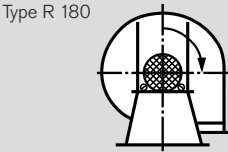
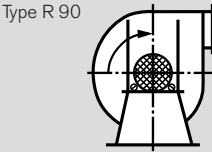
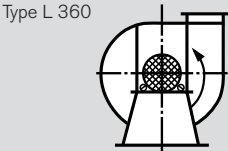
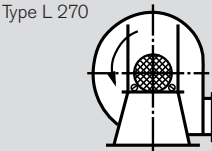
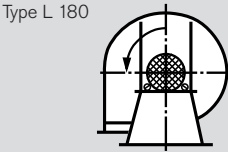
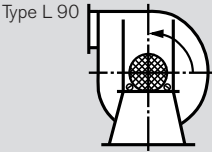

Air outlets at other angles are available on request.

Note:
The housing arrangement is to be considered as viewed from the drive side of the fan. Subsequent alteration of the alignment of the fan to its base is not possible, as the two parts are welded together during manufacture.



Burners rated up to 32 MW are tested on the world's largest test firing chamber in the R&D Centre



Burner sound absorber
Dimensionally accurate production for the best possible attenuation



Xi'an, central China: The seven WKG gas burners in this heating centre provide more than 50000 residents in the Zi Wei garden district with 115 MW of heat

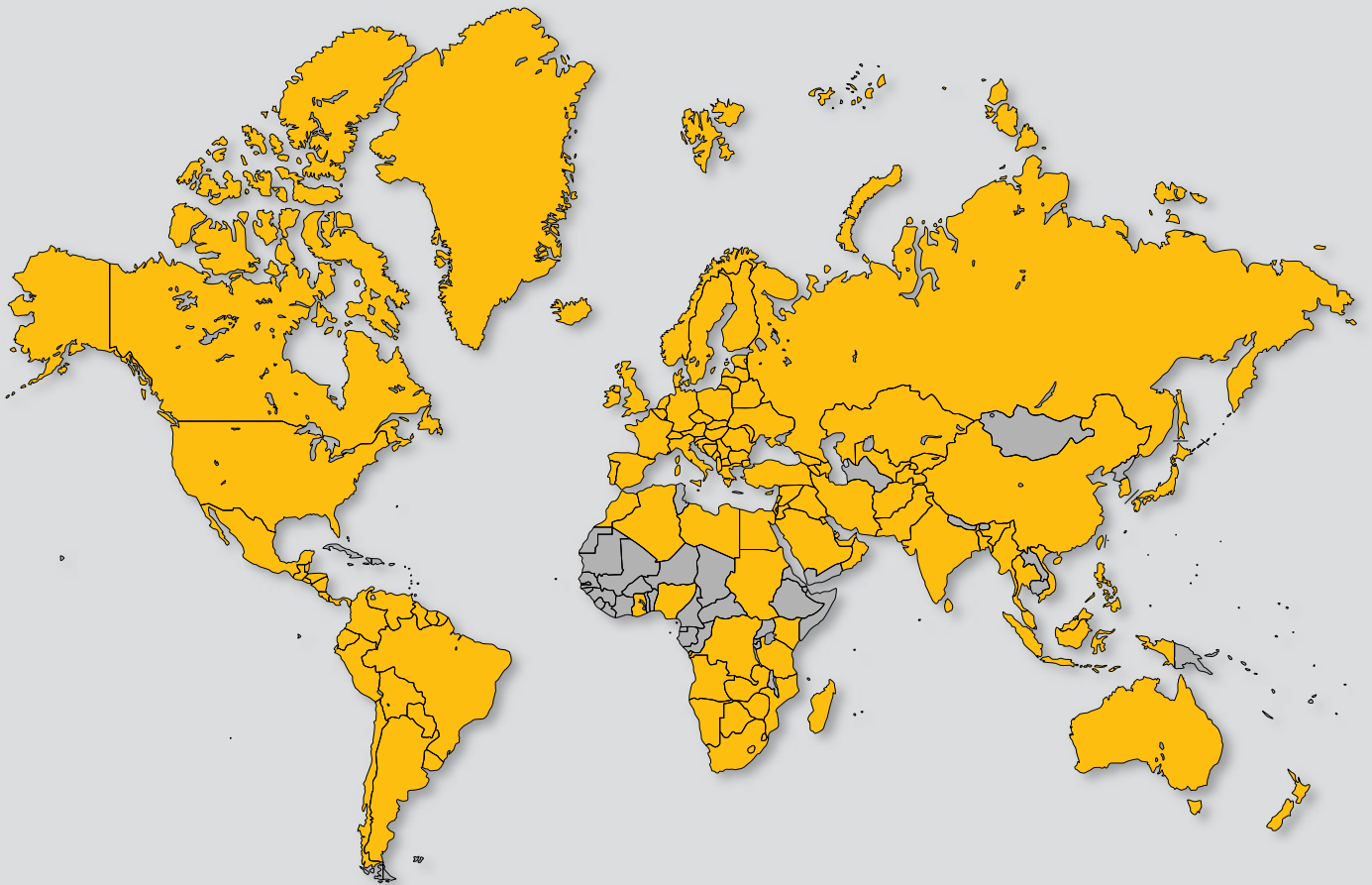

Weishaupt worldwide:

Afghanistan	Bulgaria	Faroe Islands	Israel	Madagascar	North Macedonia	Singapore	UAE
Algeria	Canada	Finland	Italy	Malaysia	Norway	Slovakia	Ukraine
Angola	Chile	France	Japan	Malta	Oman	Slovenia	United Kingdom
Argentina	China	Germany	Jordan	Mauritius	Pakistan	South Africa	Uruguay
Australia	Colombia	Ghana	Kazakhstan	Mexico	Panama	Spain	USA
Austria	Congo	Greece	Kenya	Moldova	Paraguay	Sri Lanka	Uzbekistan
Bahrain	Costa Rica	Greenland	Korea (S.)	Monaco	Peru	Sudan	Vatican City
Bangladesh	Croatia	Guatemala	Kuwait	Montenegro	Philippines	Suriname	Venezuela
Belarus	Cyprus	Guyana	Kyrgyzstan	Morocco	Poland	Sweden	Vietnam
Belgium	Czechia	Honduras	Latvia	Mozambique	Portugal	Switzerland	Zambia
Belize	Denmark	Hungary	Lebanon	Myanmar	Qatar	Syria	Zimbabwe
Bolivia	Ecuador	India	Lesotho	Namibia	Romania	Taiwan	
Bosnia-Herzegovina	Egypt	Indonesia	Libya	Netherlands	Russia	Tajikistan	
Botswana	El Salvador	Iran	Liechtenstein	New Zealand	San Marino	Tanzania	
Brazil	Estonia	Iraq	Lithuania	Nicaragua	Saudi Arabia	Thailand	
	Eswatini	Ireland	Luxembourg	Nigeria	Serbia	Turkey	